



Hidden Valley Lake Community Services District

Finance Committee Meeting

AGENDA

August 18, 2020

12:30 p.m.

DUE TO THE EVOLVING SITUATION WITH THE COVID-19 NOVEL CORONAVIRUS AND THE STATE OF CALIFORNIA STAY AT HOME ORDER, EXECUTIVE ORDER N-33-20, THIS MEETING SHALL ONLY BE AVAILABLE TO THE PUBLIC VIA TELECONFERENCE

To join this meeting go to the www.hvcsd.org select the August 17, 2020 Finance Committee Meeting select **Join Microsoft Teams Meeting** Select **Join on the web instead**.

The general public may not attend this meeting at the district's offices due to social distancing requirements. Please submit your comments to pcuadras@hvcsd.org or mail comments to the attention of: Board Secretary, Hidden Valley Lake Community Services District, 19400 Hartmann Road, Hidden Valley Lake, Ca 95467. Comments will be addressed by the Committee Chair as related to the agenda item or during Public Comment.

DATE: August 18, 2020

TIME: 12:30 pm

PLACE: Hidden Valley Lake CSD
Administration Office, GM Office
19400 Hartmann Road
Hidden Valley Lake, CA

1. CALL TO ORDER
2. PLEDGE OF ALLEGIANCE
3. ROLL CALL
4. APPROVAL OF AGENDA
5. REVIEW AND DISCUSS: WWTP Access Road Rebuilding Project in support of disaster recovery of February 2019 (DR 4434) - Solicit Bids
6. REVIEW AND DISCUSS: Meadow View Easement Sewer Replacement Project in support of CVRWQCB abatement requests originating from DR4301 and DR 4308 – Solicit Bids
7. REVIEW AND DISCUSS: OSHA – Next steps, Industrial Hygienist sampling, MSA training
8. REVIEW AND DISCUSS: Update on Delinquent Accounts
9. REVIEW AND DISCUSS: Update on NBS Rate Study
10. REVIEW AND DISCUSS: Policy #1002 Mobile/Stationary Meter Use Policy and Resolution 2020-10 Adopting Mobile and Stationary Meter Use fee
11. PUBLIC COMMENT
12. COMMITTEE MEMBER COMMENT
13. ITEMS FOR NEXT AGENDA
14. ADJOURN

Public records are available upon request. Board Packets are posted on our website at www.hvcsd.org/Meetings.

In compliance to the Americans with Disabilities Act, if you need special accommodations to participate in or attend the meeting please contact the District Office at (707)987-9201 at least 48 hours prior to the scheduled meeting.

Public shall be given the opportunity to comment on each agenda item before the Governing Board acts on that item, G.C. 54953.3. All other comments will be taken under Public Comment.

HIDDEN VALLEY LAKE CSD
 REVENUE & EXPENSE REPORT (UNAUDITED)
 AS OF: JULY 31ST, 2020

120-SEWER ENTERPRISE FUND
 FINANCIAL SUMMARY

	CURRENT BUDGET	CURRENT PERIOD	YEAR TO DATE ACTUAL	BUDGET BALANCE	% OF BUDGET
<u>REVENUE SUMMARY</u>					
ALL REVENUE	<u>1,798,153.00</u>	<u>134,130.53</u>	<u>134,130.53</u>	<u>1,664,022.47</u>	<u>7.46</u>
TOTAL REVENUES	<u>1,798,153.00</u>	<u>134,130.53</u>	<u>134,130.53</u>	<u>1,664,022.47</u>	<u>7.46</u>
<u>EXPENDITURE SUMMARY</u>					
NON-DEPARTMENTAL	777,716.00	90,846.85	90,846.85	686,869.15	11.68
ADMINISTRATION	402,258.00	27,725.27	27,725.27	374,532.73	6.89
FIELD	417,256.00	28,952.82	28,952.82	388,303.18	6.94
DIRECTORS	44,530.00	2,341.71	2,341.71	42,188.29	5.26
SPECIAL PROJECTS	178,782.00	0.00	0.00	178,782.00	0.00
CAPITAL PROJECTS & EQUIP	<u>0.00</u>	<u>0.00</u>	<u>0.00</u>	<u>0.00</u>	<u>0.00</u>
TOTAL EXPENDITURES	<u>1,820,542.00</u>	<u>149,866.65</u>	<u>149,866.65</u>	<u>1,670,675.35</u>	<u>8.23</u>
REVENUES OVER/(UNDER) EXPENDITURES	(22,389.00)	(15,736.12)	(15,736.12)	(6,652.88)	70.29

AS OF: JULY 31ST, 2020

120-SEWER ENTERPRISE FUND

REVENUES

	CURRENT BUDGET	CURRENT PERIOD	YEAR TO DATE ACTUAL	BUDGET BALANCE	% OF BUDGET
120-4020 INSPECTION FEES	500.00	100.00	100.00	400.00	20.00
120-4036 DEVELOPER SEWER FEES	0.00	0.00	0.00	0.00	0.00
120-4040 LIEN RECORDING FEES	0.00	0.00	0.00	0.00	0.00
120-4045 AVAILABILITY FEES	5,500.00	0.00	0.00	5,500.00	0.00
120-4050 SALES OF RECLAIMED WATER	110,000.00	25,023.31	25,023.31	84,976.69	22.75
120-4111 COMM SEWER USE	43,113.00	3,604.41	3,604.41	39,508.59	8.36
120-4112 GOV'T SEWER USE	900.00	64.94	64.94	835.06	7.22
120-4116 SEWER USE CHARGES	1,217,940.00	103,545.82	103,545.82	1,114,394.18	8.50
120-4210 LATE FEE	20,000.00	1,792.05	1,792.05	18,207.95	8.96
120-4300 MISC INCOME	2,500.00	0.00	0.00	2,500.00	0.00
120-4310 OTHER INCOME	0.00	0.00	0.00	0.00	0.00
120-4320 FEMA/CalOES Grants	396,000.00	0.00	0.00	396,000.00	0.00
120-4505 LEASE INCOME	1,700.00	0.00	0.00	1,700.00	0.00
120-4550 INTEREST INCOME	0.00	0.00	0.00	0.00	0.00
120-4580 TRANSFERS IN	0.00	0.00	0.00	0.00	0.00
120-4591 INCOME APPLICABLE TO PRIOR YRS	0.00	0.00	0.00	0.00	0.00
120-4955 Gain/Loss	0.00	0.00	0.00	0.00	0.00
TOTAL REVENUES	1,798,153.00	134,130.53	134,130.53	1,664,022.47	7.46

REVENUE & EXPENSE REPORT (UNAUDITED)

AS OF: JULY 31ST, 2020

120-SEWER ENTERPRISE FUND

NON-DEPARTMENTAL

EXPENDITURES

	CURRENT BUDGET	CURRENT PERIOD	YEAR TO DATE ACTUAL	BUDGET BALANCE	% OF BUDGET
120-5-00-5010 SALARY & WAGES	0.00	0.00	0.00	0.00	0.00
120-5-00-5020 EMPLOYEE BENEFITS	0.00	0.00	0.00	0.00	0.00
120-5-00-5021 RETIREMENT BENEFITS	0.00	0.00	0.00	0.00	0.00
120-5-00-5024 WORKERS' COMP INSURANCE	15,000.00	11,406.00	11,406.00	3,594.00	76.04
120-5-00-5025 RETIREE HEALTH BENEFITS	14,000.00	587.77	587.77	13,412.23	4.20
120-5-00-5026 COBRA Health & Dental	0.00	0.00	0.00	0.00	0.00
120-5-00-5040 ELECTION EXPENSE	12,000.00	0.00	0.00	12,000.00	0.00
120-5-00-5050 DEPRECIATION	0.00	0.00	0.00	0.00	0.00
120-5-00-5060 GASOLINE, OIL & FUEL	20,000.00	0.00	0.00	20,000.00	0.00
120-5-00-5061 VEHICLE MAINT	18,000.00	0.00	0.00	18,000.00	0.00
120-5-00-5062 TAXES & LIC	800.00	0.00	0.00	800.00	0.00
120-5-00-5074 INSURANCE	54,066.00	54,065.85	54,065.85	0.15	100.00
120-5-00-5075 BANK FEES	21,000.00	1,798.13	1,798.13	19,201.87	8.56
120-5-00-5080 MEMBERSHIP & SUBSCRIPTIONS	7,500.00	934.01	934.01	6,565.99	12.45
120-5-00-5092 POSTAGE & SHIPPING	7,000.00	0.00	0.00	7,000.00	0.00
120-5-00-5110 CONTRACTUAL SERVICES	0.00	0.00	0.00	0.00	0.00
120-5-00-5121 LEGAL SERVICES	20,000.00	0.00	0.00	20,000.00	0.00
120-5-00-5122 ENGINEERING SERVICES	50,000.00	0.00	0.00	50,000.00	0.00
120-5-00-5123 OTHER PROFESSIONAL SERVICE	50,000.00	4,400.00	4,400.00	45,600.00	8.80
120-5-00-5126 AUDIT SERVICES	7,500.00	0.00	0.00	7,500.00	0.00
120-5-00-5130 PRINTING & PUBLICATION	5,000.00	0.00	0.00	5,000.00	0.00
120-5-00-5135 NEWSLETTER	500.00	0.00	0.00	500.00	0.00
120-5-00-5140 RENTS & LEASES	0.00	0.00	0.00	0.00	0.00
120-5-00-5145 EQUIPMENT RENTAL	5,000.00	193.15	193.15	4,806.85	3.86
120-5-00-5148 OPERATING SUPPLIES	48,000.00	0.00	0.00	48,000.00	0.00
120-5-00-5150 REPAIR & REPLACE	145,000.00	1,932.23	1,932.23	143,067.77	1.33
120-5-00-5155 MAINT BLDG & GROUNDS	8,000.00	957.00	957.00	7,043.00	11.96
120-5-00-5156 CUSTODIAL SERVICES	16,500.00	0.00	0.00	16,500.00	0.00
120-5-00-5157 SECURITY	500.00	0.00	0.00	500.00	0.00
120-5-00-5160 SLUDGE DISPOSAL	45,000.00	0.00	0.00	45,000.00	0.00
120-5-00-5165 TERTIARY POND MAINTENANCE	50,000.00	0.00	0.00	50,000.00	0.00
120-5-00-5180 UNCOLLECTABLE ACCOUNTS	0.00	0.00	0.00	0.00	0.00
120-5-00-5191 TELEPHONE	11,000.00	874.94	874.94	10,125.06	7.95
120-5-00-5192 ELECTRICITY	65,000.00	4,167.53	4,167.53	60,832.47	6.41
120-5-00-5193 OTHER UTILITIES	2,600.00	0.00	0.00	2,600.00	0.00
120-5-00-5194 IT SERVICES	36,500.00	7,076.28	7,076.28	29,423.72	19.39
120-5-00-5195 ENV/MONITORING	35,000.00	1,700.00	1,700.00	33,300.00	4.86
120-5-00-5196 RISK MANAGEMENT	0.00	0.00	0.00	0.00	0.00
120-5-00-5198 ANNUAL OPERATING FEES	2,000.00	0.00	0.00	2,000.00	0.00
120-5-00-5310 EQUIPMENT - FIELD	1,000.00	0.00	0.00	1,000.00	0.00
120-5-00-5311 EQUIPMENT - OFFICE	1,000.00	576.47	576.47	423.53	57.65
120-5-00-5312 TOOLS - FIELD	1,500.00	0.00	0.00	1,500.00	0.00
120-5-00-5315 SAFETY EQUIPMENT	1,500.00	177.49	177.49	1,322.51	11.83
120-5-00-5510 SEWER OUTREACH	0.00	0.00	0.00	0.00	0.00
120-5-00-5545 RECORDING FEES	250.00	0.00	0.00	250.00	0.00
120-5-00-5580 TRANSFERS OUT	0.00	0.00	0.00	0.00	0.00
120-5-00-5590 NON-OPERATING OTHER	0.00	0.00	0.00	0.00	0.00
120-5-00-5591 EXPENSES APPLICABLE TO PRI	0.00	0.00	0.00	0.00	0.00
120-5-00-5600 CONTINGENCY	0.00	0.00	0.00	0.00	0.00

HIDDEN VALLEY LAKE CSD
 REVENUE & EXPENSE REPORT (UNAUDITED)
 AS OF: JULY 31ST, 2020

120-SEWER ENTERPRISE FUND
 NON-DEPARTMENTAL
 EXPENDITURES

	CURRENT BUDGET	CURRENT PERIOD	YEAR TO DATE ACTUAL	BUDGET BALANCE	% OF BUDGET
120-5-00-5650 OPERATING RESERVES	0.00	0.00	0.00	0.00	0.00
120-5-00-5700 OVER / SHORT	0.00	0.00	0.00	0.00	0.00
TOTAL NON-DEPARTMENTAL	777,716.00	90,846.85	90,846.85	686,869.15	11.68

AS OF: JULY 31ST, 2020

120-SEWER ENTERPRISE FUND

ADMINISTRATION

EXPENDITURES

	CURRENT BUDGET	CURRENT PERIOD	YEAR TO DATE ACTUAL	BUDGET BALANCE	% OF BUDGET
120-5-10-5010 SALARIES & WAGES	252,875.00	20,025.67	20,025.67	232,849.33	7.92
120-5-10-5020 EMPLOYEE BENEFITS	91,844.00	3,836.39	3,836.39	88,007.61	4.18
120-5-10-5021 RETIREMENT BENEFITS	47,189.00	3,752.75	3,752.75	43,436.25	7.95
120-5-10-5063 CERTIFICATIONS	500.00	0.00	0.00	500.00	0.00
120-5-10-5090 OFFICE SUPPLIES	4,000.00	110.46	110.46	3,889.54	2.76
120-5-10-5170 TRAVEL MILEAGE	1,500.00	0.00	0.00	1,500.00	0.00
120-5-10-5175 EDUCATION / SEMINARS	4,000.00	0.00	0.00	4,000.00	0.00
120-5-10-5179 ADM MISC EXPENSES	350.00	0.00	0.00	350.00	0.00
TOTAL ADMINISTRATION	402,258.00	27,725.27	27,725.27	374,532.73	6.89

AS OF: JULY 31ST, 2020

120-SEWER ENTERPRISE FUND

FIELD

EXPENDITURES

	CURRENT BUDGET	CURRENT PERIOD	YEAR TO DATE ACTUAL	BUDGET BALANCE	% OF BUDGET
120-5-30-5010 SALARIES & WAGES	255,455.00	19,177.81	19,177.81	236,277.19	7.51
120-5-30-5020 EMPLOYEE BENEFITS	106,340.00	6,039.28	6,039.28	100,300.72	5.68
120-5-30-5021 RETIREMENT BENEFITS	46,661.00	3,735.73	3,735.73	42,925.27	8.01
120-5-30-5022 CLOTHING ALLOWANCE	1,800.00	0.00	0.00	1,800.00	0.00
120-5-30-5063 CERTIFICATIONS	1,500.00	0.00	0.00	1,500.00	0.00
120-5-30-5090 OFFICE SUPPLIES	1,000.00	0.00	0.00	1,000.00	0.00
120-5-30-5170 TRAVEL MILEAGE	500.00	0.00	0.00	500.00	0.00
120-5-30-5175 EDUCATION / SEMINARS	4,000.00	0.00	0.00	4,000.00	0.00
TOTAL FIELD	417,256.00	28,952.82	28,952.82	388,303.18	6.94

HIDDEN VALLEY LAKE CSD
REVENUE & EXPENSE REPORT (UNAUDITED)
AS OF: JULY 31ST, 2020

120-SEWER ENTERPRISE FUND

DIRECTORS

EXPENDITURES

	CURRENT BUDGET	CURRENT PERIOD	YEAR TO DATE ACTUAL	BUDGET BALANCE	% OF BUDGET
120-5-40-5010 DIRECTORS COMPENSATION	3,000.00	269.15	269.15	2,730.85	8.97
120-5-40-5020 DIRECTOR BENEFITS	230.00	11.50	11.50	218.50	5.00
120-5-40-5030 DIRECTOR HEALTH BENEFITS	36,000.00	2,061.06	2,061.06	33,938.94	5.73
120-5-40-5170 TRAVEL MILEAGE	200.00	0.00	0.00	200.00	0.00
120-5-40-5175 EDUCATION / SEMINARS	1,500.00	0.00	0.00	1,500.00	0.00
120-5-40-5176 DIRECTOR TRAINING	3,600.00	0.00	0.00	3,600.00	0.00
TOTAL DIRECTORS	44,530.00	2,341.71	2,341.71	42,188.29	5.26

HIDDEN VALLEY LAKE CSD
 REVENUE & EXPENSE REPORT (UNAUDITED)
 AS OF: JULY 31ST, 2020

120-SEWER ENTERPRISE FUND
 SPECIAL PROJECTS
 EXPENDITURES

	CURRENT BUDGET	CURRENT PERIOD	YEAR TO DATE ACTUAL	BUDGET BALANCE	% OF BUDGET
120-5-60-6001 PW LKHVA01	0.00	0.00	0.00	0.00	0.00
120-5-60-6002 PW LKHVB02	0.00	0.00	0.00	0.00	0.00
120-5-60-6003 PW LKHVA81	0.00	0.00	0.00	0.00	0.00
120-5-60-6004 PW LKHVB82	0.00	0.00	0.00	0.00	0.00
120-5-60-6005 PW LKHVF84	0.00	0.00	0.00	0.00	0.00
120-5-60-6006 PW LKHVF83	0.00	0.00	0.00	0.00	0.00
120-5-60-6007 RAINS 2019	0.00	0.00	0.00	0.00	0.00
120-5-60-6009 ACCESS RD	178,782.00	0.00	0.00	178,782.00	0.00
TOTAL SPECIAL PROJECTS	178,782.00	0.00	0.00	178,782.00	0.00

HIDDEN VALLEY LAKE CSD
 REVENUE & EXPENSE REPORT (UNAUDITED)
 AS OF: JULY 31ST, 2020

120-SEWER ENTERPRISE FUND
 CAPITAL PROJECTS & EQUIP
 EXPENDITURES

	CURRENT BUDGET	CURRENT PERIOD	YEAR TO DATE ACTUAL	BUDGET BALANCE	% OF BUDGET
120-5-70-7101 VAC TRUCK	0.00	0.00	0.00	0.00	0.00
120-5-70-7201 I & I	0.00	0.00	0.00	0.00	0.00
120-5-70-7203 HEADWORKS RAKE	0.00	0.00	0.00	0.00	0.00
TOTAL CAPITAL PROJECTS & EQUIP	0.00	0.00	0.00	0.00	0.00
TOTAL EXPENDITURES	1,820,542.00	149,866.65	149,866.65	1,670,675.35	8.23
REVENUES OVER/(UNDER) EXPENDITURES	(22,389.00)	(15,736.12)	(15,736.12)	(6,652.88)	70.29

*** END OF REPORT ***

HIDDEN VALLEY LAKE CSD
 REVENUE & EXPENSE REPORT (UNAUDITED)
 AS OF: JULY 31ST, 2020

130-WATER ENTERPRISE FUND
 FINANCIAL SUMMARY

	CURRENT BUDGET	CURRENT PERIOD	YEAR TO DATE ACTUAL	BUDGET BALANCE	% OF BUDGET
<u>REVENUE SUMMARY</u>					
ALL REVENUE	<u>2,175,569.00</u>	<u>216,907.11</u>	<u>216,907.11</u>	<u>1,958,661.89</u>	<u>9.97</u>
TOTAL REVENUES	<u>2,175,569.00</u>	<u>216,907.11</u>	<u>216,907.11</u>	<u>1,958,661.89</u>	<u>9.97</u>
<u>EXPENDITURE SUMMARY</u>					
NON-DEPARTMENTAL	1,303,635.00	132,082.87	132,082.87	1,171,552.13	10.13
ADMINISTRATION	432,258.00	27,725.31	27,725.31	404,532.69	6.41
FIELD	387,856.00	39,764.11	39,764.11	348,091.89	10.25
DIRECTORS	51,820.00	2,341.67	2,341.67	49,478.33	4.52
CAPITAL PROJECTS & EQUIP	<u>0.00</u>	<u>0.00</u>	<u>0.00</u>	<u>0.00</u>	<u>0.00</u>
TOTAL EXPENDITURES	<u>2,175,569.00</u>	<u>201,913.96</u>	<u>201,913.96</u>	<u>1,973,655.04</u>	<u>9.28</u>
REVENUES OVER/(UNDER) EXPENDITURES	0.00	14,993.15	14,993.15 (14,993.15)	0.00

HIDDEN VALLEY LAKE CSD
 REVENUE & EXPENSE REPORT (UNAUDITED)
 AS OF: JULY 31ST, 2020

130-WATER ENTERPRISE FUND

REVENUES

	CURRENT BUDGET	CURRENT PERIOD	YEAR TO DATE ACTUAL	BUDGET BALANCE	% OF BUDGET
130-4035 RECONNECT FEE	12,000.00	205.00	205.00	11,795.00	1.71
130-4038 COMM WATER METER INSTALL	0.00	0.00	0.00	0.00	0.00
130-4039 WATER CONNECTION FEE	0.00	329.00	329.00	(329.00)	0.00
130-4040 LIEN RECORDING FEES	1,200.00	0.00	0.00	1,200.00	0.00
130-4045 AVAILABILITY FEES	22,000.00	0.00	0.00	22,000.00	0.00
130-4110 COMM WATER USE	95,295.00	10,728.60	10,728.60	84,566.40	11.26
130-4112 GOV'T WATER USE	6,000.00	462.53	462.53	5,537.47	7.71
130-4115 WATER USE	1,968,074.00	201,743.81	201,743.81	1,766,330.19	10.25
130-4117 WATER OVERAGE FEE	0.00	0.00	0.00	0.00	0.00
130-4118 WATER OVERAGE COMM	0.00	0.00	0.00	0.00	0.00
130-4119 WATER OVERAGE GOV	0.00	0.00	0.00	0.00	0.00
130-4210 LATE FEE	32,000.00	3,308.17	3,308.17	28,691.83	10.34
130-4215 RETURNED CHECK FEE	1,000.00	0.00	0.00	1,000.00	0.00
130-4300 MISC INCOME	3,000.00	130.00	130.00	2,870.00	4.33
130-4310 OTHER INCOME	1,500.00	0.00	0.00	1,500.00	0.00
130-4320 FEMA/CalOES Grants	30,000.00	0.00	0.00	30,000.00	0.00
130-4505 LEASE INCOME	0.00	0.00	0.00	0.00	0.00
130-4550 INTEREST INCOME	3,500.00	0.00	0.00	3,500.00	0.00
130-4580 TRANSFER IN	0.00	0.00	0.00	0.00	0.00
130-4591 INCOME APPLICABLE TO PRIOR YRS	0.00	0.00	0.00	0.00	0.00
130-4955 Gain/Loss	0.00	0.00	0.00	0.00	0.00
TOTAL REVENUES	2,175,569.00	216,907.11	216,907.11	1,958,661.89	9.97
	=====	=====	=====	=====	=====

REVENUE & EXPENSE REPORT (UNAUDITED)

AS OF: JULY 31ST, 2020

130-WATER ENTERPRISE FUND

NON-DEPARTMENTAL

EXPENDITURES

	CURRENT BUDGET	CURRENT PERIOD	YEAR TO DATE ACTUAL	BUDGET BALANCE	% OF BUDGET
130-5-00-5010 SALARY & WAGES	0.00	0.00	0.00	0.00	0.00
130-5-00-5020 EMPLOYEE BENEFITS	0.00	0.00	0.00	0.00	0.00
130-5-00-5021 RETIREMENT BENEFITS	0.00	0.00	0.00	0.00	0.00
130-5-00-5024 WORKERS' COMP INSURANCE	15,000.00	11,405.99	11,405.99	3,594.01	76.04
130-5-00-5025 RETIREE HEALTH BENEFITS	14,000.00	587.78	587.78	13,412.22	4.20
130-5-00-5026 COBRA Health & Dental	0.00	0.00	0.00	0.00	0.00
130-5-00-5040 ELECTION EXPENSE	12,000.00	0.00	0.00	12,000.00	0.00
130-5-00-5050 DEPRECIATION	0.00	0.00	0.00	0.00	0.00
130-5-00-5060 GASOLINE, OIL & FUEL	20,000.00	0.00	0.00	20,000.00	0.00
130-5-00-5061 VEHICLE MAINT	12,500.00	0.00	0.00	12,500.00	0.00
130-5-00-5062 TAXES & LIC	1,200.00	0.00	0.00	1,200.00	0.00
130-5-00-5074 INSURANCE	54,055.00	54,065.84	54,065.84 (10.84)	100.02
130-5-00-5075 BANK FEES	21,000.00	1,798.11	1,798.11	19,201.89	8.56
130-5-00-5080 MEMBERSHIP & SUBSCRIPTIONS	24,600.00	934.00	934.00	23,666.00	3.80
130-5-00-5092 POSTAGE & SHIPPING	6,500.00	0.00	0.00	6,500.00	0.00
130-5-00-5110 CONTRACTUAL SERVICES	0.00	0.00	0.00	0.00	0.00
130-5-00-5121 LEGAL SERVICES	20,000.00	0.00	0.00	20,000.00	0.00
130-5-00-5122 ENGINEERING SERVICES	60,000.00	0.00	0.00	60,000.00	0.00
130-5-00-5123 OTHER PROFESSIONAL SERVICE	50,000.00	4,400.00	4,400.00	45,600.00	8.80
130-5-00-5124 WATER RIGHTS	50,000.00	0.00	0.00	50,000.00	0.00
130-5-00-5126 AUDIT SERVICES	7,500.00	0.00	0.00	7,500.00	0.00
130-5-00-5130 PRINTING & PUBLICATION	7,500.00	0.00	0.00	7,500.00	0.00
130-5-00-5135 NEWSLETTER	500.00	0.00	0.00	500.00	0.00
130-5-00-5140 RENT & LEASES	0.00	0.00	0.00	0.00	0.00
130-5-00-5145 EQUIPMENT RENTAL	45,000.00	193.14	193.14	44,806.86	0.43
130-5-00-5148 OPERATING SUPPLIES	5,000.00	0.00	0.00	5,000.00	0.00
130-5-00-5150 REPAIR & REPLACE	125,000.00	1,882.91	1,882.91	123,117.09	1.51
130-5-00-5155 MAINT BLDG & GROUNDS	12,000.00	957.00	957.00	11,043.00	7.98
130-5-00-5156 CUSTODIAL SERVICES	4,200.00	0.00	0.00	4,200.00	0.00
130-5-00-5157 SECURITY	5,000.00	0.00	0.00	5,000.00	0.00
130-5-00-5180 UNCOLLECTABLE ACCOUNTS	0.00	0.00	0.00	0.00	0.00
130-5-00-5191 TELEPHONE	11,000.00	874.94	874.94	10,125.06	7.95
130-5-00-5192 ELECTRICITY	150,000.00	18,878.21	18,878.21	131,121.79	12.59
130-5-00-5193 OTHER UTILITIES	2,500.00	0.00	0.00	2,500.00	0.00
130-5-00-5194 IT SERVICES	36,500.00	7,076.27	7,076.27	29,423.73	19.39
130-5-00-5195 ENV/MONITORING	17,000.00	342.00	342.00	16,658.00	2.01
130-5-00-5196 RISK MANAGEMENT	0.00	0.00	0.00	0.00	0.00
130-5-00-5198 ANNUAL OPERATING FEES	32,000.00	0.00	0.00	32,000.00	0.00
130-5-00-5310 EQUIPMENT - FIELD	1,000.00	0.00	0.00	1,000.00	0.00
130-5-00-5311 EQUIPMENT - OFFICE	1,000.00	576.46	576.46	423.54	57.65
130-5-00-5312 TOOLS - FIELD	1,500.00	0.00	0.00	1,500.00	0.00
130-5-00-5315 SAFETY EQUIPMENT	1,500.00	177.49	177.49	1,322.51	11.83
130-5-00-5505 WATER CONSERVATION	9,000.00	0.00	0.00	9,000.00	0.00
130-5-00-5520 HYDRANT DEPOSIT REFUND	0.00	0.00	0.00	0.00	0.00
130-5-00-5545 RECORDING FEES	250.00	0.00	0.00	250.00	0.00
130-5-00-5580 TRANSFERS OUT	467,830.00	27,932.73	27,932.73	439,897.27	5.97
130-5-00-5590 NON-OPERATING OTHER	0.00	0.00	0.00	0.00	0.00
130-5-00-5591 EXPENSES APPLICABLE TO PRI	0.00	0.00	0.00	0.00	0.00
130-5-00-5600 CONTINGENCY	0.00	0.00	0.00	0.00	0.00

HIDDEN VALLEY LAKE CSD
REVENUE & EXPENSE REPORT (UNAUDITED)
AS OF: JULY 31ST, 2020

130-WATER ENTERPRISE FUND
NON-DEPARTMENTAL
EXPENDITURES

	CURRENT BUDGET	CURRENT PERIOD	YEAR TO DATE ACTUAL	BUDGET BALANCE	% OF BUDGET
130-5-00-5650 OPERATING RESERVES	0.00	0.00	0.00	0.00	0.00
TOTAL NON-DEPARTMENTAL	1,303,635.00	132,082.87	132,082.87	1,171,552.13	10.13

HIDDEN VALLEY LAKE CSD
REVENUE & EXPENSE REPORT (UNAUDITED)
AS OF: JULY 31ST, 2020

130-WATER ENTERPRISE FUND
ADMINISTRATION
EXPENDITURES

	CURRENT BUDGET	CURRENT PERIOD	YEAR TO DATE ACTUAL	BUDGET BALANCE	% OF BUDGET
130-5-10-5010 SALARIES & WAGES	282,875.00	20,025.78	20,025.78	262,849.22	7.08
130-5-10-5020 EMPLOYEE BENEFITS	91,844.00	3,836.39	3,836.39	88,007.61	4.18
130-5-10-5021 RETIREMENT BENEFITS	47,189.00	3,752.70	3,752.70	43,436.30	7.95
130-5-10-5063 CERTIFICATIONS	0.00	0.00	0.00	0.00	0.00
130-5-10-5090 OFFICE SUPPLIES	4,000.00	110.44	110.44	3,889.56	2.76
130-5-10-5170 TRAVEL MILEAGE	2,000.00	0.00	0.00	2,000.00	0.00
130-5-10-5175 EDUCATION / SEMINARS	4,000.00	0.00	0.00	4,000.00	0.00
130-5-10-5179 ADM MISC EXPENSES	350.00	0.00	0.00	350.00	0.00
130-5-10-5505 WATER CONSERVATION	0.00	0.00	0.00	0.00	0.00
TOTAL ADMINISTRATION	432,258.00	27,725.31	27,725.31	404,532.69	6.41

HIDDEN VALLEY LAKE CSD
REVENUE & EXPENSE REPORT (UNAUDITED)
AS OF: JULY 31ST, 2020

130-WATER ENTERPRISE FUND

FIELD

EXPENDITURES

	CURRENT BUDGET	CURRENT PERIOD	YEAR TO DATE ACTUAL	BUDGET BALANCE	% OF BUDGET
130-5-30-5010 SALARIES & WAGES	225,455.00	29,033.53	29,033.53	196,421.47	12.88
130-5-30-5020 EMPLOYEE BENEFITS	106,340.00	6,039.28	6,039.28	100,300.72	5.68
130-5-30-5021 RETIREMENT BENEFITS	46,661.00	4,691.30	4,691.30	41,969.70	10.05
130-5-30-5022 CLOTHING ALLOWANCE	1,800.00	0.00	0.00	1,800.00	0.00
130-5-30-5063 CERTIFICATIONS	600.00	0.00	0.00	600.00	0.00
130-5-30-5090 OFFICE SUPPLIES	1,000.00	0.00	0.00	1,000.00	0.00
130-5-30-5170 TRAVEL MILEAGE	2,000.00	0.00	0.00	2,000.00	0.00
130-5-30-5175 EDUCATION / SEMINARS	4,000.00	0.00	0.00	4,000.00	0.00
TOTAL FIELD	387,856.00	39,764.11	39,764.11	348,091.89	10.25

HIDDEN VALLEY LAKE CSD
REVENUE & EXPENSE REPORT (UNAUDITED)
AS OF: JULY 31ST, 2020

130-WATER ENTERPRISE FUND

DIRECTORS

EXPENDITURES

	CURRENT BUDGET	CURRENT PERIOD	YEAR TO DATE ACTUAL	BUDGET BALANCE	% OF BUDGET
130-5-40-5010 DIRECTORS COMPENSATION	3,000.00	269.10	269.10	2,730.90	8.97
130-5-40-5020 DIRECTOR BENEFITS	120.00	11.50	11.50	108.50	9.58
130-5-40-5030 DIRECTOR HEALTH BENEFITS	42,000.00	2,061.07	2,061.07	39,938.93	4.91
130-5-40-5080 MEMBERSHIP & SUBSCRIPTION	0.00	0.00	0.00	0.00	0.00
130-5-40-5170 TRAVEL MILEAGE	200.00	0.00	0.00	200.00	0.00
130-5-40-5175 EDUCATION / SEMINARS	1,500.00	0.00	0.00	1,500.00	0.00
130-5-40-5176 DIRECTOR TRAINING	5,000.00	0.00	0.00	5,000.00	0.00
TOTAL DIRECTORS	51,820.00	2,341.67	2,341.67	49,478.33	4.52

HIDDEN VALLEY LAKE CSD
 REVENUE & EXPENSE REPORT (UNAUDITED)
 AS OF: JULY 31ST, 2020

130-WATER ENTERPRISE FUND
 CAPITAL PROJECTS & EQUIP
 EXPENDITURES

	CURRENT BUDGET	CURRENT PERIOD	YEAR TO DATE ACTUAL	BUDGET BALANCE	% OF BUDGET
130-5-70-7101 VAC TRUCK	0.00	0.00	0.00	0.00	0.00
130-5-70-7202 GENERATORS	0.00	0.00	0.00	0.00	0.00
130-5-70-7204 TANK 9	0.00	0.00	0.00	0.00	0.00
130-5-70-7205 MMN WTR MAIN	0.00	0.00	0.00	0.00	0.00
<hr/>					
TOTAL CAPITAL PROJECTS & EQUIP	0.00	0.00	0.00	0.00	0.00
<hr/>					
TOTAL EXPENDITURES	2,175,569.00	201,913.96	201,913.96	1,973,655.04	9.28
	=====	=====	=====	=====	=====
REVENUES OVER/(UNDER) EXPENDITURES	0.00	14,993.15	14,993.15 (14,993.15)	0.00
	=====	=====	=====	=====	=====

*** END OF REPORT ***

**ACTION OF
HIDDEN VALLEY LAKE COMMUNITY SERVICES DISTRICT**

DATE: August 18, 2020

AGENDA ITEM: Authorize Staff to solicit bids for the WWTP Access Road Rebuilding Project in support of disaster recovery of February 2019 (DR 4434)

RECOMMENDATIONS: Authorize Staff to solicit bids for the WWTP Access Road Rebuilding Project in support of disaster recovery of February 2019 (DR 4434).

FINANCIAL IMPACT: \$99,092 (\$6,193)

FUND/AMT: 314

BACKGROUND:

The Federally declared disaster #4434 that occurred in late February 2019, damaged the WWTP Access Road. Original Engineering estimates to repair this damage totaled \$178,782. This repair project was submitted to CalOES and FEMA in late 2019 and approved in February 2020. The project was later obligated by FEMA in April 2020.

The Revised Estimate is \$99,092 which has reduced the amount of materials necessary by re-purposing existing chip seal has also eliminated the purchase of terra cells.

When a Federal disaster is declared for a particular county, agencies such as HVLCSD are eligible to submit a Request for Public Assistance (RPA). Once an RPA is received, CalOES, FEMA and the requesting agency work in concert to establish emergency and permanent repair costs caused by the disaster. For both types of repair work, FEMA will obligate 75% of the cost, and CalOES will obligate 75% of the remaining 25% (18.75% of total cost). This leaves the remaining 6.25% the obligation of the requesting agency to complete these repairs. In the case of the WWTP Access Road Repair, \$6,193 would be the final financial responsibility of HVLCSD. A notable FEMA stipulation is the deadline in which HVLCSD has to complete these repairs. Eighteen months from the date of disaster declaration (5/18/19), is the date in which all repairs must be complete (11/18/20).

Since the Design Contract was awarded to Coastland at the June 16, 2020 Board of Directors meeting, they have worked diligently together with staff to develop this detailed Bid Solicitation Package. If it pleases the Board, an approval of this bid solicitation package will “pave” the way towards a potential award of construction contract at the September 15, 2020 Board of Directors Meeting, which will in turn help facilitate a construction completion date of 10/3020.

Modification to recommendation and/or other actions:

I, Penny Cuadras, Secretary to the Board, do hereby certify that the foregoing action was regularly introduced, passed, and adopted by said Board of Directors at a regular board meeting thereof held on August 18, 2020 by the following vote:

Ayes:

Noes:

Abstain:

Absent:

Attest: _____

Secretary to the Board

Hidden Valley Lake Community Services District
Engineer's Estimate
WWTP Access Road Improvements
August 2020

Item No.	Item Description	Estimated Quantity	Unit of Measure	Unit Cost	Item Total
1	Traffic Control System	1	L.S.	\$ 2,500.00	\$ 2,500
2	Roadway Surface Preparation	4,704	S.Y.	\$ 1.50	\$ 7,056
3	Chip-Seal (double chip seal)	4,704	S.Y.	\$ 12.00	\$ 56,448
4	Mobilization	1	L.S.	\$ 3,300.00	\$ 3,300

Construction Cost \$ 69,304

Contingency (10%) \$ 6,930

Total Construction \$ 76,234

Engineering (authorized and in progress) \$ 10,660

CM and Inspection (16%) \$ 12,198

Total Cost \$ 99,092



HIDDEN VALLEY LAKE COMMUNITY SERVICES DISTRICT
HIDDEN VALLEY LAKE, CALIFORNIA

NOTICE TO CONTRACTORS

SPECIAL PROVISIONS, PROPOSAL AND CONTRACT

FOR

**WWTP ACCESS ROAD
IMPROVEMENTS PROJECT**

FOR USE IN CONNECTION WITH SPECIFIED
STANDARD SPECIFICATIONS AND STANDARD PLANS DATED 2015
OF THE CALIFORNIA DEPARTMENT OF TRANSPORTATION

AND

CURRENT GENERAL PREVAILING WAGE RATES AND
LABOR SURCHARGE AND EQUIPMENT RENTAL RATES
OF THE CALIFORNIA DEPARTMENT OF TRANSPORTATION

BID OPENING DATE:

September 10, 2020 at 11 A.M.

HIDDEN VALLEY LAKE COMMUNITY SERVICES DISTRICT
19400 Hartmann Rd
Hidden Valley Lake, CA 95467

NOTICE INVITING BIDS

NOTICE IS HEREBY GIVEN that sealed bids will be received by the Hidden Lake Valley Community Services, 19400 Hartmann Road, Hidden Valley Lake, California until the hour of **September 10, 2020, at 11 a.m.** at which time they will be publicly opened and read aloud in the conference room of the District office, for:

WWTP ACCESS ROAD IMPROVEMENTS PROJECT

Complete bid packages, including project plans, technical specifications, bid forms and contract documents may be secured at the office of:

Coastland Civil Engineering
1400 Neotomas Ave.
Santa Rosa, California, 95405
Phone (707) 571-8005, fax (707) 571-8037

by emailing Ann Pomilia at pomilia@coastlandcivil.com. The bid documents are available electronically for free or by hard copy for the non-refundable cost of **\$30 per set. If mailing is desired an additional non-refundable cost of \$15.00 per set will be required.** Checks shall be made payable to "Coastland Civil Engineering". Any questions regarding the bid documents should be emailed to Jennifer Melman at Coastland Civil Engineering at melman@coastlandcivil.com.

In accordance with California Public Contract Code Section 3400, bidders may propose equals of products listed in the technical specifications or project plans by manufacturer name, brand or model number, unless the technical specifications or plans specify that the product is necessary to match others in use. Complete information for products proposed as equals must be submitted to the District for review at least 10 working days before the time specified for bid opening in accordance with the bidders instructions contained in the bid package.

In accordance with California Public Contract Code Section 20170, all bids must be presented under sealed cover and include one of the following forms of bidder's security: cash, cashier's check made payable to the District, certified check made payable to the District, or a bidder's bond. The amount of bidder's security provided must equal at least ten (10) percent of the total of the bid price for the base bid and the additive or deductive items listed in this notice. The successful bidder must submit to the District complete, executed copies of all required documents within ten (10) working days of receiving written notice of award of the project. Bidder's security of any successful bidder that fails to do so will be forfeited to the District. Such required documents include, but are not limited to, a payment or labor and materials bond in an amount of at least 100 percent of the amount payable by the terms of the project contract and that satisfies the requirements of California Civil Code Section 9554, and a performance bond in an amount of at least 100 percent of the amount payable by the terms of the contract. All project bonds must be executed by an admitted surety insurer in accordance with applicable law and acceptable to the District.

Pursuant to the provisions of Section 1770 et seq. of the California Labor Code the Director of Industrial Relations for the State of California has ascertained the current general prevailing rate of wages for

employer purposes, in Lake County, State of California. Not less than the general prevailing rate of per diem wages for work of a similar character in Lake County and not less than the general prevailing rate of per diem wages for holiday work fixed as provided in the California Labor Code shall be paid to all workers engaged in performing the project.

Pursuant to the provisions of Section 1771.1 of the California Labor Code, a contractor or subcontractor shall not be qualified to bid on, be listed in a bid proposal, subject to the requirements of Section 4104 of the Public Contract Code, or engage in the performance of any contract for public work, as defined in Chapter 1 of Part 7 of Division 2 of the California Labor Code, unless currently registered and qualified to perform public work pursuant to Civil Code Section 1725.5. ***Please note: It is not a violation of Section 1771.1 for an unregistered contractor to submit a bid that is authorized by Section 7029.1 of the Business and Professions Code or by Section 10164 or 20103.5 of the Public Contract Code, provided the contractor is registered to perform public work pursuant to Section 1725.5 at the time the contract is awarded.*** Any bids submitted without proof that Bidder and any listed subcontractor(s) are currently registered and qualified to perform public work, pursuant to Labor Code Section 1725.5, shall not be accepted by the District.

In accordance with the California Labor Code Section 1773.2, copies of the applicable determinations are available at the District office and may be reviewed upon request.

In accordance with California Civil Code Section 1771.4, the project is subject to compliance monitoring and enforcement by the Department of Industrial Relations.

In accordance with California Public Contract Code Section 3300, a valid class A California contractor's license is required to bid on the project.

In accordance with California Public Contract Code Section 22300, except where prohibited by federal regulations or policies, the successful bidder may, on request and at its expense, substitute securities in lieu of amounts withheld by the District from progress payments to ensure performance under the contract in accordance with the contract documents.

The District reserves the right to postpone the date and time for the opening of proposals at any time prior to the date and time announced in the advertisement in accordance with applicable law.

The District reserves the right to reject any and all bids or to waive any defects or irregularity in bidding in accordance with applicable law. In accordance with California Public Contract Code Section 20103.8, if the District elects to award a contract for performance of the project, the contract will be awarded in accordance with California Public Contract Code Section 20162 and other applicable law to the responsible bidder submitting a responsive bid with the lowest total bid price for the total base bid without consideration of the bid price for any additive or deductive items. The lowest responsive bidder and any listed subcontractors will be checked to ensure that they are clear from the Federal Procurement and Non-Procurement Program List. All bids will remain valid for 90 days after the bid opening. Except as permitted by law and subject to all applicable remedies, including forfeiture of bidder's security, bidders may not withdraw their bid during the 90 day period after the bid opening.

By order of
The General Manager of the Hidden Valley Lake Community Services District
Lake County, California.

TABLE OF CONTENTS

Instructions to Bidders.....	BB-1
Bidder's Check List.....	BB-11
Proposal and Schedule of Bid Prices.....	BB-12
Bid Bond.....	BB-14
Contractor License Information.....	BB-16
List of Subcontractors.....	BB-17
Workers Compensation Insurance Certification.....	BB-19
Non-Collusion Declaration.....	BB-20
Debarment Certification	BB-21
Debarment and Suspension Certification	BB-22
Public Contract Code Section 10285.1 Statement.....	BB-23
Public Contract Code Section 10162 Questionnaire	BB-24
Public Contract Code Section 10232 Statement.....	BB-25
Bidder's Signature Page	BB-26
Contract Check List.....	BB-28
Agreement.....	BB-29
Performance Bond	BB-34
Payment Bond.....	BB-36
Contract Change Order.....	BB-38
Maintenance Bond.....	BB-40
Escrow Agreement.....	BB-42

GENERAL PROVISIONS

<u>SECTION</u>	<u>TITLE</u>	
1.	Definitions	1
2.	Scope of Work.....	5
3.	Control of Work and Material and Changes in Work.....	7
4.	Trenching and Utilities and Project Facilities	20
5.	Prosecution and Progress of the Work.....	25
6.	Contractor Responsibilities.....	31
7.	Measurement and Payment.....	55
8.	Project Acceptance and Closeout	59
9.	Remedies and Disputes.....	61
10	Special Provisions.....	75

PROJECT EXHIBIT DRAWING (1 Sheet)

INSTRUCTIONS TO BIDDERS

1. DEFINITIONS

- 1.1 Bid forms. The bid forms are the documents listed in the Bidder's Check List in the bid package Table of Contents as comprising the documents that must be submitted for each bid for it to be deemed complete.
- 1.2 Bid package. A complete bid package consists of the following documents: Notice Inviting Bids, Instructions to Bidders, Bidder's Check List, Proposal and Schedule of Bid Prices, Bid Bond, Contractor License Information, List of Proposed Subcontractors, Workers Compensation Insurance Certification, Non-collusion Declaration, Debarment Certification, Debarment and Suspension Certification, Public Contract Code Section 10285.1, Public Contract Code Section 10162 Questionnaire, Public Contract Code Section 10232 Statement, Bidder's Questionnaire, if any, Bidder's Signature Page, Contract Check List, Contract, Performance Bond, Payment Bond, Contract Change Order, Maintenance Bond, Escrow for Security Deposit Agreement, General Provisions, Special Provisions, and the Project Plans.
- 1.3 Contract documents. The contract documents are all of the documents incorporated into the final Project contract as listed in the contract.
- 1.4 Project. The Project is the **WWTP Access Road Improvements Project** described in the bid package.
- 1.5 Project Plans. The Project Plans are the primarily graphic detailed requirements concerning the Project contained in the bid package.
- 1.6 Technical Specifications. The Technical Specifications provide detailed requirements concerning the Project and are contained in Special Provisions in the bid package.

2. BIDDER'S REPRESENTATIONS

Each bidder by submitting a bid represents that:

- 2.1 The bidder has read and understands the bid package and the bid is in accordance with all of the requirements of the bid package and applicable law.
- 2.2 Neither the bidder nor any subcontractor included on the list of proposed subcontractors submitted with the bid is ineligible to perform work on public works projects pursuant to California Labor Code Sections 1777.1 or 1777.7.
- 2.3 The bidder understands that quantities of unit price items may vary from the estimates provided in the technical specifications.
- 2.4 Representatives of the bidder have visited the Project site and have familiarized themselves with the conditions under which the Project work is to be performed so as to ensure that the Project work may be performed for the amount bid.

- 2.5 The bidder has informed the District in writing no later than five (5) working days prior to the time specified for bid opening of any apparent conflicts, errors, or ambiguities contained in the bid package or between the contents of the bid package and the Project site.

3. EXAMINATION OF PLANS, SPECIFICATIONS, CONTRACT, AND WORK SITE

- 3-1 The bidder shall examine carefully the work site, the Project Plans and Technical Specifications, and the entire Bid Package. The submission of a bid shall be conclusive evidence that the bidder has investigated and is satisfied as to the general and local conditions to be encountered, as to the character, quality and scope of work to be performed, the quantities of materials to be furnished and as to the requirements of the Contract Documents.
- 3-2 The submission of a bid shall also be conclusive evidence that the bidder is satisfied as to the character, quality and quantity of surface and subsurface materials or obstacles to be encountered insofar as this information was reasonably ascertainable from an inspection of the site and the records of exploratory work done by the District as shown in the bid documents, as well as from the Project Plans and Technical Specifications.
- 3-3 Where the District has made investigations of work site conditions including subsurface conditions in areas where Work is to be performed, or in other areas, that may constitute possible local material sources, bidders may, upon request, inspect the records of the District as to those investigations.
- 3-4 Where there has been prior construction by the District or other public agencies within the project limits, records of the prior construction that are currently in the possession of the District and that have been used by, or are known to, the designers and administrators of the project will be made available for inspection by bidders, upon request, subject to this Section 3. Such records may include, but are not limited to, as-built drawings, design calculations, foundation and site studies, project reports and other data assembled in connection with the investigation, design, construction and maintenance of the prior projects.
- 3-5 Inspection of the records of investigations and project records in the possession of the District may be made at the District Office.
- 3-6 When a log of test borings or other record of geotechnical data obtained by the District's investigation of surface and subsurface conditions is included with the Project Plans, it is furnished for the bidders' information and its use shall be subject to this Section 3.
- 3-7 In some instances, information considered by the District to be of possible interest to bidders has been compiled as "Materials Information." The use of the "Materials Information" shall be subject to the conditions and limitations set forth in this Section 3.
- 3-8 When cross sections are not included with the Project Plans, but are available, bidders may inspect the cross sections and obtain copies for their use, at their expense.
- 3-9 When cross sections are included with the Project Plans, it is expressly understood and agreed that the cross sections do not constitute part of the Agreement, do not necessarily represent actual site conditions or show location, character, dimensions and details of Work to be performed, and

are included in the Project Plans only for the convenience of bidders and their use is subject to the conditions and limitations set forth in this Section 3.

- 3-10 When contour maps were used in the design of the project, bidders may inspect those maps, and if available, they may obtain copies for their use.
- 3-11 The availability or use of information described in this Section 3 is not to be construed in any way as a waiver of any of the provisions in this Section 3 and bidders are cautioned to make independent investigations and examinations as they deem necessary to be satisfied as to conditions to be encountered in the performance of the Work and, with respect to possible local material sources, the quality and quantity of material available from the property and the type and extent of processing that may be required in order to produce material conforming to the requirements of the Technical Specifications.
- 3-12 The District assumes no responsibility for conclusions or interpretations made by a bidder based on the information or data made available by the District. The District does not assume responsibility for representation made by its officers or agents before the execution of the Agreement concerning surface or subsurface conditions, unless that representation is expressly stated in the Contract Documents.
- 3-13 No conclusions or interpretations made by a bidder from the information and data made available by the District will relieve a bidder from properly fulfilling the terms of the Agreement.

4. PRE-BID COMMUNICATION AND INTERPRETATION OF THE BID PACKAGE

- 4.1 Any bidder that discovers any apparent conflicts, errors, or ambiguities contained in the bid package or between the contents of the bid package and the Project site, or that has questions or requires clarification concerning the bid package or its intent must inform the District in writing as soon as reasonably possible, but no later than five (5) working days before the date specified for bid opening. Such notice to the District must be sent to the address specified in the Notice Inviting Bids for questions concerning the bid package or sent via electronic mail to: melman@coastlandcivil.com. Questions received less than five (5) working days before the time specified for opening bids may not be answered.
- 4.2 Any interpretation, correction or change of the bid package prior to bid opening will be made by addendum signed by an authorized representative of the District and transmitted to all bid package recipients. No other interpretation or information concerning the bid package issued prior to the date specified for opening bids will be binding. All addenda signed by an authorized representative of the District and issued prior to the time and date specified for opening bids will form a part of the contract documents and must be acknowledged on the bid forms. Any changes, exceptions or conditions concerning the Project and/or the bid package submitted by any bidder as part of a bid may render that bid non-responsive.

5. PRE-BID ACCESS TO THE PROJECT SITE

- 5.1 Prior to submitting a bid, it will be the sole responsibility of each bidder to conduct any additional examination, investigation, exploration, testing, study or other inquiry and to obtain any additional information pertaining to the physical conditions (including surface, subsurface, and underground utilities) at or near the Project site that may affect the cost, progress, or performance

of the Project, and that the bidder deems are necessary to prepare its bid for performance of the Project in accordance with the bid package and contract documents. Bidders seeking any such additional examination or other inquiries or information concerning the Project will do so at the bidder's sole expense.

- 5.2 Bidders seeking to conduct any additional examination or other inquiry at the Project site must request site access from the District at least two (2) working days in advance. The location of any excavation, boring or other invasive testing will be subject to approval on behalf of the District and any other agencies with jurisdiction over such testing. Bidders may not conduct tests at the Project site prior to obtaining District approval. The District may require bidders to execute an access agreement prior to approving testing at the Project site. Once approved testing is complete, Bidders must fill all trenches or holes, restore all pavement to match existing structural section, and otherwise clean up and restore the test site to its pre-test condition.

6. BIDDING PROCEDURE

- 6.1 Bids must be delivered to the Hidden Lake Valley Community Services, 19400 Hartmann Road, Hidden Valley Lake, California, no later than the time and date specified in the Notice Inviting Bids. Bids will be opened and read publicly at that time. Bids that are submitted late according to the official time kept by the District will be returned unopened. Telephones for use by bidders are not available at the District offices.
- 6.2 In accordance with California Public Contract Code Section 20170, Bids must be presented under sealed cover. Bids must be submitted using the bid forms furnished with the bid package. Bids must include all documents listed in the Bidder's Check List completed in accordance with the bid package. Bids must bear the bidder's legal name and be signed by a representative authorized to bind the bidder. Bids must be typed or written in ink. Corrections may be made if initialed by the individual signing the bid. No oral or telegraphic modifications of bids, including facsimile modifications, will be considered. Bids that are incomplete or that are not presented on the bid forms furnished with the bid package may be deemed non-responsive.
- 6.3 Each bid must give the full business address of the bidder. Bids of partnerships must furnish the full name of all partners and must be signed in the partnership name by one of the members of the partnership, or by an authorized representative, followed by the printed name and title of the person signing. Bids of corporations must be signed with the legal name of the corporation, followed by the name of the state of incorporation and by the signature and designation of the president, secretary or other person authorized to bind the corporation. The name of each person signing shall also be typed or printed below the signature. Upon request of the District, bidders will furnish satisfactory evidence of the authority of the person signing the bid. Bids of joint ventures must include a certified copy of the legal agreement constituting the joint venture.
- 6.4 No person, firm, corporation, partnership or legal joint venture may submit more than one bid for the Project. However, a person, firm, corporation, partnership or legal joint venture that has submitted a subcontract proposal to a bidder, or that has quoted prices on materials to a bidder may submit a subcontract proposal, quote prices to other bidders and submit its own bid.
- 6.5 In accordance with California Public Contract Code Section 20170, all bids must include one of the forms of bidder's security specified in the Notice Inviting Bids in an amount of at least ten (10) per cent of the total of the bid prices for the base bid and those additive or deductive items specifically identified in the Notice Inviting Bids for the purpose of determining the lowest price

bid. Bidders that elect to provide bidder's security in the form of a bid bond must execute a bid bond using the form provided in the bid forms. The bidder's security is tendered as a guarantee that the successful bidder, if awarded the Project contract, will execute and submit to the District all required bonds, certificates of insurance, completed contract forms and other documents listed in the Contract Check List and enter into a contract with the District within ten (10) working days of receipt of the notice of award. The bidder's security of any successful bidder that fails to do so will be forfeited to the District. All bidders' security not forfeited to the District will be returned once a successful bidder provides all required documents and enters a contract with the District in accordance with all applicable bid package requirements. Forfeiture of the bidder's security to the District will not waive or otherwise limit any other remedy available to the District under applicable law.

- 6.6 In accordance with California Business and Professions Code Section 7028.15, Public Contract Code Section 20103.5, and as specified in the Notice Inviting Bids, all Project work must be performed by properly licensed contractors and subcontractors with active licenses in good standing as of the date and time specified for bid opening, or, if the Project involves federal funds, no later than the time the Project contract is awarded. Bidders must verify their Contractor's License number and license expiration date on the proposal cover page under penalty of perjury. Bids that do not satisfy applicable licensing requirements will be considered non-responsive and rejected and may subject the bidder to criminal and/or civil penalties.
- 6.7 In accordance with California Civil Code Section 1771.1, the District shall accept bids only from bidders which (along with all listed subcontractors) are currently registered and qualified to perform public work pursuant to Civil Code Section 1725.5. The District may, however, accept a non-complying bid provided that bidder (and all listed subcontractors) are registered and qualified at the time of award.
- 6.8 If the bid forms include a bidder's questionnaire, all bids must include a completed bidder's questionnaire on the forms provided. By submitting a bid, bidders authorize District representatives to verify any and all information provided on the bidder's questionnaire and agree to indemnify, defend and hold harmless the District and its officials, officers, employees, agents and volunteers to full the extent permitted by law from and against any claims, liability or causes of action, including, without limitation, legal fees and costs, arising out of verification of the information provided on the bidder's questionnaire, and/or arising out of use of information provided in the bidder's questionnaire to determine, in accordance with applicable law, the qualification of the bidder for performing the Project.
- 6.9 Bids may be withdrawn prior to the time set for bid opening by a written request signed by an authorized representative of the bidder filed with the District. The bid security submitted with bids so withdrawn will be returned to the bidder. Bidders that have withdrawn their bid in accordance with this provision may submit a new bid prior to the time set for bid opening in accordance with all applicable bid package requirements. Bids may not be withdrawn during the ninety day period after the time set for bid opening except as permitted by law pursuant to California Public Contract Code Section 5100 and following. Any other bid withdrawal will result in forfeiture of the bidder's bid security to the District.

7. BID PROTESTS

Any protest of the proposed Project award must be submitted in writing to the District no later than 5:00 PM on the third business day following the date of the bid opening.

- 7.1 The protest must contain a complete statement of the basis for the protest.
- 7.2 The protest must state the facts and refer to the specific portion of the document or the specific statute that forms the basis for the protest. The protest must include the name, address, and telephone number of the person representing the protesting party.
- 7.3 The party filing the protest must concurrently transmit a copy of the protest to the proposed awardee.
- 7.4 The party filing the protest must have actually submitted a bid for the Project. A subcontractor of a party filing a bid for the Project may not submit a bid protest. A party may not rely on the bid protest submitted by another bidder, but must timely pursue its own protest.
- 7.5 The procedure and time limits set forth in these Instructions to Bidders are mandatory and are the bidders' sole and exclusive remedy in the event of a bid protest. Any bidder's failure to fully comply with these procedures shall constitute a waiver of any right to further pursue a bid protest, including filing of a challenge of the award pursuant to the California Public Contract Code, filing of a claim pursuant to the California Government Code, or filing of any other legal proceedings.
- 7.6 The District shall review all timely protests prior to award of the Project. The District shall not be required to hold an administrative hearing to consider any protests, but may do so at its option. At the time of the District's Board of Directors consideration of the Project award, the Board of Directors shall also consider the merits of any timely protests. The Board of Directors may either reject the protest and award to the lowest responsible bidder or accept the protest and award the bid to the next lowest responsible bidder. Nothing in this section shall be construed as a waiver of the Board of Directors right to reject all bids.

8. AWARD

- 8.1 In accordance with applicable law, the District reserves the right to reject any or all bids and to waive any informality in any bid. The District reserves the right to accept any portion of any bid, unless the bid package expressly provides that the award will be made as a whole. If the District elects to award a contract for performance of the Project, the contract will be awarded in accordance with California Public Contract Code Section 20162 and other applicable law to the responsible bidder submitting a responsive bid with the lowest total bid price for the base bid without consideration of the bid price for any additive or deductive alternate items. In accordance with the contract documents and other applicable law, the District may add or deduct items of work from the Project after the lowest responsible bidder is determined.
- 8.2 The successful bidder must submit to the District complete, executed copies of all documents specified in the Contract Checklist within ten (10) working days of receiving written notice of award of the Project. Bidder's security of any successful bidder that fails to do so will be forfeited to the District.
- 8.3 The successful bidder and any subcontractors and others engaged in performance of the Project must have valid local business license(s), as applicable, before commencing work on the Project.

8.4 Upon verifying that the successful bidder has provided complete, executed copies of all documents specified in the Contract Checklist an authorized District representative will execute the Project contract, and the District will issue to the successful bidder a notice to proceed specifying the Project commencement date. The number of days within which the Project must be complete begins to run on the Project commencement date.

9. PRICING

9.1 If an inconsistency exists between the amount listed for a unit price in a bid and the total listed for that bid item (e.g., if the total listed for a bid item does not equal the unit price listed in the bid multiplied by the quantity listed), subject to applicable law, the unit price will be deemed to accurately reflect the bidder's intent concerning the bid item and the intended total for the bid item will be deemed to be the unit price as listed in the bid multiplied by the quantity listed.

9.2 If the Project bid price is a lump sum total made up of smaller individual bid item prices and an inconsistency exists between the lump sum total bid price and any individual bid item price, subject to applicable law, the individual bid item prices as listed in the bid will be deemed to accurately reflect the bidder's intended bid for the Project and the intended lump sum total bid for the Project will be deemed to be the sum of the individual bid item prices as listed in the bid, even if that sum is different from the amount actually listed as the lump sum total bid for the Project.

9.3 Any federal, state, or local tax payable on articles to be furnished for the Project shall be included in the lump sum total bid price and paid by the Contractor under the contract.

10. QUANTITIES

10.1 Quantities, including but not limited to, material or labor quantities, that are provided in the bid package concerning the Project are estimates only and are provided solely as a general indication of the Project scope. The District does not warrant that such quantity estimates provided in the bid package represent the actual quantities required to perform the Project in accordance with the contract documents. Such quantity estimates do not bind the District, and bidders should not rely on them in preparing their bids. Each bidder is solely responsible for determining the quantities on which to base their bids in light of information contained in the bid package, bidder investigation and analysis of the Project and the Project site, and any other analysis or expertise of the bidder concerning the Project.

10.2 The District may amend, decrease or increase the Project work in accordance with the bidding package and the contract documents. If the District amends, decreases or increases the Project work prior to award of the Project each bidder will be solely responsible for determining the revised quantities, if any, on which to base their bid in light of information contained in the bid package and any amendments or addenda to the bid package, bidder investigation and analysis of the Project as amended, decreased or increased, the Project site, and any other analysis or expertise of the bidder concerning the Project.

11. SUBSTITUTION OF "OR EQUAL" ITEMS

11.1 In accordance with California Public Contract Code Section 3400, where the Technical Specifications or Project Plans list products by manufacturer's name, brand or model number such information indicates the quality and utility of the items desired and does not restrict

bidders to that manufacturer's name, brand or model number, unless the Technical Specifications or Project plans specify that the listed product is necessary to match others in use on a particular public improvement either completed or in the course of completion. Except where the Technical Specifications indicate that a particular brand product is necessary to match others in use, when a manufacturer's name, brand or model number is listed, it shall be construed to be followed by the words "or equal" whether or not those words in fact follow the manufacturer's name, brand name or model number listed in the Technical Specifications or Project Plans. Unless the Technical Specifications or Project Plans indicate that a particular brand product is necessary to match others in use, bidders may propose equals of products listed by manufacturer name, brand name or model number.

- 11.2 Complete information for products proposed as equals must be submitted to the District for review by at least ten (10) working days before the time specified for opening bids. To be considered, proposals concerning products proposed as equals must include sufficient information to permit the District to determine whether the products proposed as equals will satisfy the same performance requirements as products listed by manufacturer's name, brand or model number. Such performance requirements may include, but are not limited to, size, strength, function, appearance, ease of maintenance and repair, and useful life requirements. Proposals concerning products proposed as equals that are submitted later than ten (10) working days before the time specified for opening bids will not be considered. Failure to bid products specified by manufacturer name, brand name or model number where the Technical Specifications or Project Plans specify that a particular product is necessary to match others in use, or where no proposal concerning products proposed as equals has been submitted in accordance with this provision may render a bid non-responsive.

12. SUBCONTRACTING

- 12.1 Bids must be in accordance with the requirements of the Subletting and Subcontracting Fair Practices, Act, California Public Contract Code Section 4100 and following. Bids must include a completed list of proposed subcontractors on the form included in the bid package. In accordance with California Public Contract Code Section 4104, completed lists of proposed subcontractors must include the name, business location, the portion (type or trade), and dollar amount of the Project work to be subcontracted for each subcontractor that will perform a portion of the Project work (including special fabrication and installation of a portion of the work) valued in excess of one half of one percent of the total Project bid price. If the Project work includes construction of streets or highways, the completed list of proposed subcontractors must include the subcontractor name, business location, type of work and dollar amount to be subcontracted for each subcontractor that will perform a portion of the Project work (including special fabrication and installation of a portion of the work) valued in excess of one half of one percent of the total Project bid price, or ten thousand dollars (\$10,000), whichever is greater.
- 12.2 In accordance with California Public Contract Code Section 4106, for any portion of the Project work with a value of more than one half of one percent of the total Project bid price for which no subcontractor is listed, or for which more than one subcontractor is listed, bidders certify by submitting their bids that they are qualified to perform that portion of the Project work and that they will perform that portion of the Project work with their own forces. Bidders may not substitute another subcontractor for a subcontractor listed in their bid except as permitted by the District in accordance with Section 4107 and following of the California Public Contract Code.

13. ASSIGNMENT

Bidders may not assign, sublet, sell, transfer, or otherwise dispose of their bid or any right, title or interest in their bid, or their obligations under their bid, without the written consent of an authorized representative of the District. Any purported assignment, subletting, sale, transfer or other disposition of a bid or any interest in a bid, or of any obligations under a bid without such written consent will be void and of no effect.

14. BONDS

- 14.1 The successful bidder must submit to the District a performance bond within ten (10) working days of receiving written notice of award. If the Project involves expenditures in excess of twenty-five thousand dollars (\$25,000), the successful bidder must submit to the District a payment or labor and materials bond within ten (10) working days of receiving written notice of award. Prior to issuance of the final Project payment, the successful bidder must submit a maintenance bond. All bonds must be executed by corporate sureties who are admitted surety insurers in the State of California in accordance with applicable law and acceptable to the District. Individual sureties will not be accepted. All Project bonds must be executed using the forms provided in the bid package.
- 14.2 In accordance with California Civil Code Section 9554, the payment or labor and materials bond must be in the amount of one hundred percent of the total amount payable by the terms of the Project contract and guarantee payment to persons listed in California Civil Code Section 9100 for work performed and for charges for materials, supplies, and equipment provided under the Project contract (including amounts due under or subject to the Unemployment Insurance Code).
- 14.3 The performance bond must be in the amount of one hundred percent of the amount payable by the terms of the Project contract to guarantee the faithful performance of the Project work.
- 14.4 The maintenance bond must be in the amount of twenty percent of the final Project contract amount and guaranty the Project work against defects in materials, equipment, workmanship, or needed repair for one year from the District's acceptance of the Project work.

15. LABOR LAWS

- 15.1 Bidders must comply with applicable provisions of the California Labor Code.
- 15.2 In accordance with California Labor Code Section 1861, bids must include a workers compensation insurance certification on the form included in the bid package.
- 15.3 In accordance with California Labor Code Section 1771, not less than the general prevailing rate of per diem wages for work of a similar character in the locality in which the Project is to be performed, and not less than the general prevailing rate of per diem wages for holiday and overtime work fixed as provided in the California Labor Code shall be paid to all workers engaged in performing the Project.

- 15.4 In accordance with California Labor Code Section 1770 and following, the Director of Industrial Relations has determined the general prevailing wage per diem rates for work in the locality in which the Project is to be performed. In accordance with California Labor Code Section 1773, the District has obtained the general prevailing rate of per diem wages and the general rate for holiday and overtime work in the locality in which the Project is to be performed for each craft, classification or type of worker needed to perform the Project. In accordance with California Labor Code Section 1773.2, copies of the prevailing rate of per diem wages are on file at the District office and will be made available on request.
- 15.5 In accordance with California Labor Code Section 1777.1, contractors and subcontractors that are found guilty of willfully violating Chapter 1 of Part 7 of Division 2 of the Labor Code (except for Section 1777.5), or that are found guilty of such violations with intent to defraud, and entities in which such contractors or subcontractors have any interest, may be ineligible to bid on, be awarded, or perform Project work as a subcontractor.

BIDDER'S CHECK LIST

Did You:

- _____ Submit equal product proposals, if any, in accordance with the instructions to bidders included in the bid package at least 10 working days before the time specified for opening bids?

- _____ Include with your bid properly completed, accurate copies of the following documents in the following order using the forms included in the bid package:
 - _____ Bidder's check list?
 - _____ Proposal and Schedule of Bid Prices that state the bid as intended?
 - _____ If any, Copies of each addendum issued signed and dated on behalf of the bidder?
 - _____ Executed bid bond?
 - _____ Contractor license information?
 - _____ Contractor DIR registration information?
 - _____ List of subcontractors, including DIR registration information?
 - _____ Workers compensation insurance certification?
 - _____ Signed and notarized Non-Collusion Declaration?
 - _____ Debarment certification?
 - _____ Bidder's questionnaire, if any?
 - _____ Executed bidder's signature page?

- _____ Arrange to have the sealed bid delivered to the District offices at 19400 Hartmann Road, Hidden Valley Lake, CA 95467 on or before the time specified for bid opening in the notice inviting bids?

PROPOSAL

For: WWTP Access Road Improvements Project

For the Hidden Valley Lake Community Services District, Lake County, California.

TO THE BOARD OF DIRECTORS
OF THE HIDDEN VALLEY LAKE COMMUNITY SERVICES DISTRICT

The undersigned, as bidder, declares that it has carefully examined the work, the annexed proposed form of contract, and agrees that if this Proposal is accepted to contract with the Hidden Valley Lake Community Services District, under the form of contract annexed hereto, to provide all the necessary tools, apparatus, and other means of accomplishing the work as specified in the contract in the manner and time herein prescribed, and in accordance with the requirements of the District as therein set forth, and to take in full payment thereof the following prices of the work to be done completely performed to the satisfaction of the Hidden Valley Lake Community Services District, to-wit:

Contractor's Bid Proposal

Item No.	Item Description	Estimated Quantity	Unit of Measure	Unit Cost	Item Total
1	Traffic Control System	1	L.S.	\$	\$
2	Roadway Surface Preparation	4,704	S.Y.	\$	\$
3	Chip-Seal (double chip seal)	4,704	S.Y.	\$	\$
4	Mobilization	1	L.S.	\$	\$

\$

Written Amount

Dollars

The undersigned further agrees to deliver and to complete the work within **10 working days**, from the date of issuance, by the District, of instructions to proceed with the work, and within 10 days of the date of mailing of the notice of award, to enter into and execute and provide to the District the necessary contract with the necessary bonds and other required documents, and in case of default in executing the necessary contract within the time fixed by the Instructions to Bidders, the bidder's security accompanying this bid shall become the property of and be forfeited to the District.

Prime Contractor _____

License # _____ Expiration Date _____

DIR Registration # _____ Expiration Date _____

Contractor's License number and expiration date are herein stated under penalty of perjury.

By: _____ Title: _____

Dated this _____ day of _____, 2020

(Corporate Seal)

Corporate Signature

Address: _____

Phone No.: _____

President's signature _____

Secretary's signature _____

Corporation organized under the laws of the State of _____

Partnership Name: _____

Address: _____

Names of Co-Partners and Addresses: _____

Names of Individuals and Addresses: _____

NOTE: Sign in proper space above.

HIDDEN VALLEY LAKE COMMUNITY SERVICES DISTRICT

19400 Hartman Road
Hidden Valley Lake, California 95467

BID BOND

(NOTE: Bidders must use this form, use of any other bond form may render a bid non-responsive)

KNOW ALL MEN BY THESE PRESENTS:

That we, as PRINCIPAL, and _____, a (sole proprietorship/corporation/partnership/joint venture) organized and existing under and by virtue of the laws of the State of _____ and an admitted surety insurer authorized to do business in the State of California, as SURETY, are held and firmly bound unto the Hidden Valley Lake Community Services District, as OBLIGEE, in a penal sum equal to ten-percent (10%) the total bid price including the base bid and alternates specified in the proposal of the PRINCIPAL, to the OBLIGEE for the work described below, which penal sum is _____ (\$ _____) lawful money of the United States of America, for the payment of which sum well and truly to be made, we, and each of us, bind ourselves, our heirs, executors, administrators, successors, and assigns, jointly and severally, firmly by these presents.

THE CONDITION OF THIS OBLIGATION IS SUCH that whereas the PRINCIPAL has submitted the accompanying proposal dated _____, _____ to the OBLIGEE, for the **WWTP Access Road Improvements Project** (designated as the "Project") which proposal is hereby made a part hereof;

NOW THEREFORE, if the PRINCIPAL shall not withdraw said proposal within the ninety (90) day period following the opening of bids, and if the PRINCIPAL receives written notice that the Project is awarded to the PRINCIPAL and shall, within ten (10) calendar days of receiving such notice: enter into a written contract with the OBLIGEE in the form prescribed in the bid package issued by the OBLIGEE concerning the Project; and give insurance and bond with good and sufficient sureties guaranteeing the faithful performance and proper fulfillment of such contract and guaranteeing payment for labor and materials used for performance of the contract as required by law; and file with the OBLIGEE all required documents and do all other thing required in accordance with the bid package issued by the OBLIGEE concerning the Project for the contract between the PRINCIPAL and the OBLIGEE to become effective and for work to commence in accordance with the bid package issued by the OBLIGEE concerning the Project , or, in the event of withdrawal of the accompanying proposal within the ninety (90) day period following the opening of bids; or failure by the PRINCIPAL to enter into such contract with the OBLIGEE or to give the OBLIGEE such bonds or to file any other documents or to do any other things required in the bid package issued by the OBLIGEE for the Project, if the PRINCIPAL shall pay the OBLIGEE the difference between the total bid price in the accompanying proposal and the amount for which the OBLIGEE may procure the required performance, if the latter amount be in excess of the former, together with all costs incurred by the OBLIGEE in again attempting to let the Project, and if the said PRINCIPAL shall fully reimburse and save harmless the OBLIGEE from any damage sustained by the OBLIGEE through failure of the PRINCIPAL to enter into the written contract or to file the required performance or labor and material bonds, or to file any other required documents or to do any other things required for the contract between the PRINCIPAL and the OBLIGEE to become effective and the work to commence in accordance with the bid package issued by the OBLIGEE

concerning the Project, then this obligation shall be null and void; otherwise, it shall be and remain in full force and effect.

SURETY, for value received, hereby stipulates and agrees that no change, extension of time, alteration or addition to the terms of the bid or contract documents for the Project, or to the specifications included in the same, or to the work to be performed thereunder, or to the notice inviting bids, or to any other documents concerning the Project, shall in anywise affect SURETY's obligation under this bond, and SURETY hereby waives notice of any such change, extension of time, alteration or addition to such bid or contract documents.

In the event suit is brought upon this bond by the OBLIGEE and judgment is recovered, the SURETY shall pay all costs incurred by the OBLIGEE in such suit, including a reasonable attorney's fee to be fixed by the Court.

IN WITNESS WHEREOF, the above-bound parties have executed this instrument under their several seals this _____ day of _____, _____, the name and corporate seals of each corporate party being hereto affixed and these presents duly signed by their undersigned representatives, pursuant to authority of their governing bodies.

(Corporate Seal) PRINCIPAL _____
By _____

(Acknowledgement) Title _____
SURETY _____
(Corporate Seal)

By _____
(Attorney-in-fact)

(Acknowledgement) Title _____

(NOTE TO SURETY COMPANY: A certified copy of unrevoked resolution of authority for the attorney-in-fact must be submitted with and attached to the executed bid bond.)

CONTRACTOR LICENSE INFORMATION

The bidder acknowledges that a license is required for performance of Hidden Valley Lake Community Services District **WWTP Access Road Improvements Project**.

The bidder holds the following California Contractors License(s):

- 1. License No. _____, Class _____, Expiration Date _____
- 2. License No. _____, Class _____, Expiration Date _____
- 3. License No. _____, Class _____, Expiration Date _____
- 4. License No. _____, Class _____, Expiration Date _____
- 5. License No. _____, Class _____, Expiration Date _____
- 6. License No. _____, Class _____, Expiration Date _____
- 7. License No. _____, Class _____, Expiration Date _____
- 8. License No. _____, Class _____, Expiration Date _____
- 9. License No. _____, Class _____, Expiration Date _____
- 10. License No. _____, Class _____, Expiration Date _____

Bidder's Taxpayer Identification No. _____

LIST OF SUBCONTRACTORS

In accordance with the requirements of the Subletting and Subcontracting Fair Practices Act, California Public Contract Code Section 4100 and following, listed below are the name, business location, and the portion (type or trade) of the Project work to be subcontracted to each subcontractor that will perform a portion of the Project work (including special fabrication and installation of a portion of the work) valued in excess of one half of one percent of the total bid price. If the Project work includes construction of streets or highways, listed below are the name, business location, and the portion (type or trade) of the Project Work to be subcontracted to each subcontractor that will perform a portion of the Project work (including special fabrication and installation of a portion of the work) valued in excess of one half of one percent of the total Project bid price, or ten thousand dollars, whichever is greater. Also listed below are the proposed subcontract dollar amount and current California Contractor's License Number(s) for each proposed subcontractor. Bids that fail to include complete proposed subcontractor information in accordance with this form and Public Contract Code Section 4100 and following may be deemed non-responsive.

In accordance with California Public Contract Code Section 4106, for any portion of the Project work with a value of more than one half of one percent of the total bid price for which no subcontractor is listed, or for which more than one subcontractor is listed, the bidder certifies by submission of its bid that the bidder is qualified to perform that portion of the Project work and that the bidder will perform that portion of the Project work with its own forces. The penalties listed in California Public Contract Code Section 4111 will apply to any substitution of another subcontractor for a subcontractor listed below except as permitted by the District in accordance with Section 4107 and following of the California Public Contract Code.

Subcontractor Name _____

Business Location _____

Trade _____

Subcontract Amount _____

Current Contractor's License No.(s) _____

Current DIR Registration No. _____

2. Subcontractor Name _____

Business Location _____

Trade _____

Subcontract Amount _____

Current Contractor's License No.(s) _____

Current DIR Registration No. _____

3. Subcontractor Name _____
Business Location _____
Trade _____
Subcontract Amount _____
Current Contractor's License No.(s) _____
Current DIR Registration No. _____
4. Subcontractor Name _____
Business Location _____
Trade _____
Subcontract Amount _____
Current Contractor's License No.(s) _____
Current DIR Registration No. _____
5. Subcontractor Name _____
Business Location _____
Trade _____
Subcontract Amount _____
Current Contractor's License No.(s) _____
Current DIR Registration No. _____
6. Subcontractor Name _____
Business Location _____
Trade _____
Subcontract Amount _____
Current Contractor's License No.(s) _____
Current DIR Registration No. _____

WORKERS COMPENSATION INSURANCE CERTIFICATION

By submitting its bid the bidder certifies as follows:

I am aware of the provisions of California Labor Code Section 3700, which require every employer to be insured against liability for workmen's compensation or to undertake self-insurance in accordance with the provisions of the Labor Code, and I will comply with such provisions before commencing performance of the work of this Contract.

**NON-COLLUSION DECLARATION
TO BE EXECUTED BY BIDDER
AND SUBMITTED WITH BID**

The undersigned declares:

I am the _____ of _____, the party making the foregoing bid. The bid is not made in the interest of, or on behalf of, any undisclosed person, partnership, company, association, organization, or corporation. The bid is genuine and not collusive or sham. The bidder has not directly or indirectly induced or solicited any other bidder to put in a false or sham bid. The bidder has not directly or indirectly colluded, conspired, connived, or agreed with any bidder or anyone else to put in a sham bid, or to refrain from bidding. The bidder has not in any manner, directly or indirectly, sought by agreement, communication, or conference with anyone to fix the bid price of the bidder or any other bidder, or to fix any overhead, profit, or cost element of the bid price, or of that of any other bidder. All statements contained in the bid are true. The bidder has not, directly or indirectly, submitted his or her bid price or any breakdown thereof, or the contents thereof, or divulged information or data relative thereto, to any corporation, partnership, company, association, organization, bid depository, or to any member or agent thereof, to effectuate a collusive or sham bid, and has not paid, and will not pay, any person or entity for such purpose.

Any person executing this declaration on behalf of a bidder that is a corporation, partnership, joint venture, limited liability company, limited liability partnership, or any other entity, hereby represents that he or she has full power to execute, and does execute, this declaration on behalf of the bidder.

I declare under penalty of perjury under the laws of the State of California that the foregoing is true and correct and that this declaration is executed on _____[date], at _____[city], _____[state]."

DEBARMENT CERTIFICATION

By submitting its bid, the bidder certifies in accordance with California Public Contract Code Section 6109 that neither the bidder nor any subcontractor included on the list of proposed subcontractors submitted with the bid is ineligible to perform work on public works projects pursuant to California Labor Code Sections 1777.1 or 1777.7. In accordance with California Public Contract Code Section 6109, Contractors and subcontractors who are ineligible to perform work on public works projects pursuant to California Labor Code Sections 1777.1 or 1777.7 may neither bid on, be awarded or perform as a subcontractor on public works projects.

TITLE 49, CODE OF FEDERAL REGULATIONS - PART 29
DEBARMENT AND SUSPENSION CERTIFICATION

The bidder, under penalty of perjury, certifies that, except as noted below, he/she or any person associated therewith in the capacity of District, partner, director, officer, manager:

1. Is not currently under suspension, debarment, voluntary exclusion, or determination of ineligibility by any federal agency; and
2. Has not been suspended, debarred, voluntarily excluded or determined ineligible by any Federal Agency within the past 3 years; and
3. Does not have a proposed debarment pending; and,
4. Has not been indicted, convicted, or had a civil judgment rendered against it by a court of competent jurisdiction in any matter involving fraud or official misconduct within the past 3 years.

If there are any exceptions to this certification, insert the exceptions in the following space:

Exceptions will not necessarily result in denial of award, but will be considered in determining bidder responsibility. For any exception noted above, indicate below to whom it applies, initiating agency, and dates of action.

PUBLIC CONTRACT CODE SECTION 10285.1 STATEMENT

In accordance with Public Contract Code Section 10285.1 (Chapter 376, Stats, 1986), The bidder hereby declares under penalty of perjury under the laws of the State of California that the bidder has _____, has not _____ been convicted within the preceding three years of any offenses referred to in that section, including any charge of fraud, bribery, collusion, conspiracy, or any other act in violation of any state or federal antitrust law in connection with the bidding upon, award of, or performance of, any public works contract, as defined in Public Contract Code Section 1100, including the Regents of the University of California or the Trustees of the California State University. The term "bidder" is understood to include any partner, member, officer, director, responsible managing officer, or responsible managing employee thereof, as referred to in Section 10285.1.

Note: The bidder must place a check mark after "has" or "has not" in one of the blank spaces provided.

The above Statement is part of the Proposal. Signing the Contractor's Proposal on the signature portion thereof shall also constitute signature of this Statement.

Bidders are cautioned that making false certification may subject the certifier to criminal prosecution.

PUBLIC CONTRACT CODE SECTION 10162 QUESTIONNAIRE

In accordance with Public Contract Code Section 10162, The Bidder shall complete, under penalty of perjury, the following questionnaire:

Has the bidder, any officer of the bidder, or any employee of the bidder who has a proprietary interest in the bidder, ever been disqualified, removed, or otherwise prevented from bidding on, or completing a federal, state, or local government project because of a violation of law or a safety regulation?

Yes _____ No _____

If the answer is "Yes", explain the circumstances in the following space.

PUBLIC CONTRACT SECTION 10232 STATEMENT

In accordance with Public Contract Code Section 10232, the Contractor hereby states under penalty of perjury that no more than one final unappealable finding of contempt of court by a federal court has been issued against the Contractor within the immediately preceding two year period because of the Contractor's failure to comply with an order of a federal court which orders the Contractor to comply with an order of the National Labor Relations Board.

BIDDER'S SIGNATURE PAGE

By signing this proposal the bidder certifies, under penalty of perjury under the laws of the State of California, that the information submitted with this proposal for the Hidden Valley Lake Community Services District **WWTP Access Road Improvements Project** ("Project"), which information includes, but is not limited to, the Bidder's Check List, Proposal and Schedule of Bid Prices, Bid Bond, Contractor License Information, List of Subcontractors, Workers Compensation Insurance Certification, Non-Collusion Declaration, Debarment Certification, Debarment and Suspension Certification, Public Contract Code Section 10285.1 Statement, Public Contract Code Section 10162 Questionnaire, Public Contract Code Section 10232 Statement and Bidder's Questionnaire, if any, is accurate, true and correct, and is submitted in accordance with the requirements of the bid package issued by the Hidden Valley Lake Community Services District concerning Project and applicable law. By signing this proposal the bidder representative specified below certifies that he or she is legally authorized to bind the bidder.

The bidder agrees to deliver and to complete the Project within **10 working days** from the date of issuance, by the District, of instructions to proceed with the Project, and within 10 days of the date of mailing of the notice of award, to enter into and execute and provide to the District the Project contract, bonds and all other documents specified in the Contract Check List included in the bid package, and in case of default in executing the Project contract within the time fixed by the Instructions to Bidders, the bidder's security accompanying this bid shall become the property of and be forfeited to the Hidden Valley Lake Community Services District.

Prime Contractor _____

By: _____ Title: _____

Dated this _____ day of _____, 2020

(Corporate Seal)

Corporate signature

Address: _____

Phone No.: _____

President's signature _____

Secretary's signature _____

Corporation organized under the laws of the State of _____

Partnership Name: _____

Address: _____

Names of Co-Partners and Addresses:

Names of Individuals and Addresses:

NOTE: Sign in proper space above.

Date: _____

(Typed or printed name)

(Signature)

(Bidder)

Bidder business address (street, city, state and zip code)

Bidder Business phone: () _____

Bidder Business fax: () _____

CONTRACT CHECK LIST

Complete, accurate, executed copies of the following documents must be submitted to the Hidden Valley Lake Community Services District in accordance with the bid package issued by the District within ten (10) working days of receiving written notice of award of the project. The bidder's security of any successful bidder that fails to do so will be forfeited to the District.

_____ Contract Check List

_____ Agreement

_____ Performance Bond

_____ Payment Bond

_____ Certificates of Insurance and Endorsements

_____ Escrow for Deposit Agreement, if applicable

_____ General Conditions

AGREEMENT

The Hidden Valley Lake Community Services District, (“District”) enters into this agreement, dated for reference purposes only, with _____ (“Contractor”).

RECITALS

- A. NOTICE INVITING BIDS. The District gave notice inviting bids to be submitted by 11:00 a.m. on **September 10, 2020** for the **WWTP Access Road Improvements Project** by published notice and/or posting in accordance with California Public Contract Code Section 20164 and other applicable law.
- B. BID OPENING. On **September 10, 2020**, District representatives opened the bids for the **WWTP Access Road Improvements Project** and read the bids aloud.
- C. PROJECT AWARD. On _____, the District awarded the **WWTP Access Road Improvements Project** to the Contractor and directed District staff to send the Contractor written notice of award of the project. The District conditioned award of the project on the Contractor’s providing executed copies of all documents specified in the contract check list included in the bid package within ten (10) working days of receiving written notice of award of the project.
- D. REQUIRED DOCUMENTS. The Contractor has provided the District executed copies of all documents specified in the contract check list included in the bid package within ten (10) working days of receiving written notice of award.

AGREEMENT TERMS

The District and the Contractor agree as follows:

1. THE WORK. The Contractor shall furnish all equipment, tools, apparatus, facilities, material labor, and skill necessary to perform and complete in a good and workmanlike manner the **WWTP Access Road Improvements Project** (“Work”) as shown in the Technical Specifications and Project Plans in accordance with the Contract Documents and applicable law.
2. LOCATION OF WORK. The Work will be performed at the following locations:
WWTP Access Road, Hidden Valley Lake, CA
3. TIME FOR COMPLETION. The Contractor must complete the Work in accordance with the Contract Documents within **10 working days** from the date specified in the District’s Notice to Proceed (“Time for Completion”).
4. REMEDIES FOR FAILURE TO TIMELY COMPLETE THE WORK. If the Contractor fails to fully perform the Work in accordance with the Contract Documents by the Time for Completion, as such time may be amended by change order or other modification to this agreement in accordance with its terms, and/or if the Contractor fails, by the Time for Completion, to fully perform all of the Contractor’s obligations under this agreement that have accrued by the Time for Completion, the Contractor will become liable to the District for all resulting loss and damage in accordance with the Contract Documents and applicable law. The District’s remedies for the

Contractor's failure to perform include, but are not limited to, assessment of liquidated damages of **\$1,500 per day** in accordance with California Government Code Section 53069.85 and Section 7-1.02 of the General Provisions, and/or obtaining or providing for substitute performance in accordance with the Contract Documents.

5. CONTRACT PRICE AND PAYMENT. As full compensation in consideration of completion of the Work in accordance with the Contract Documents and in consideration of the fulfillment of all of the Contractor's obligations under the Contract Documents, the District will pay the Contractor in lawful money of the United States the total price of \$_____ (the "Contract Price") as specified in the Contractor's completed Bid Schedule dated _____, _____, and attached to and incorporated in this agreement. Payment to the Contractor under this agreement will be for Work actually performed in accordance with the Contract Documents and will be made in accordance with the requirements of the Contract Documents and applicable law. The District will have no obligation to pay the Contractor any amount in excess of the Contract Price unless this agreement is first modified in accordance with its terms. The District's obligation to pay the Contractor under this agreement is subject to and may be offset by charges that may apply to the Contractor under this agreement. Such charges include but are not limited to, charges for liquidated damages and/or substitute performance in accordance with the Contract Documents.

6. PREVAILING WAGES. In accordance with California Labor Code Section 1771, not less than the general prevailing rate of per diem wages for work of a similar character in the locality in which the Work is to be performed, and not less than the general prevailing rate of per diem wages for holiday and overtime work fixed as provided in the California Labor Code must be paid to all workers engaged in performing the Work. In accordance with California Labor Code Section 1770 and following, the Director of Industrial Relations has determined the general prevailing wage per diem rates for the locality in which the Work is to be performed. In accordance with California Labor Code Section 1773, the District has obtained the general prevailing rate of per diem wages and the general rate for holiday and overtime work in the locality in which the Work is to be performed for each craft, classification or type of worker needed to perform the project. In accordance with California Labor Code Section 1773.2, copies of the prevailing rate of per diem wages are on file at the office of Coastland Civil Engineering and will be made available on request. Throughout the performance of the Work the Contractor must comply with all provisions of the Contract Documents and all applicable laws and regulations that apply to wages earned in performance of the Work.

7. THE CONTRACT DOCUMENTS. This agreement consists of the following documents ("Contract Documents"), all of which are incorporated into and made a part of this agreement as if set forth in full. In the event of a conflict between or among the Contract Documents, precedence will be in the following order:
 - 7.1 This agreement and change orders and other amendments to this agreement signed by authorized representatives of the District and the Contractor.
 - 7.2 The General Provisions and change orders and other amendments to the General Conditions signed by authorized representatives of the District and the Contractor.
 - 7.3 The Special Provisions, addenda to the Special Provisions signed by authorized representatives of the District and issued prior to bid opening, Equal Product Proposals

accepted by the District and signed by authorized District representatives prior to bid opening, and change orders and other amendments to the Technical Specifications signed by authorized representatives of the District and the Contractor.

- 7.4 The Project Plans, addenda to the Project Plans signed by authorized representatives of the District and issued prior to bid opening, Equal Product Proposals accepted by the District and signed by authorized District representatives prior to bid opening, and change orders and other amendments to the Project Plans signed by authorized representatives of the District and the Contractor.
- 7.5 Notice Inviting Bids.
- 7.6 Instructions to Bidders.
- 7.7 The successful bidder's completed Proposal Form and Bidder's Sheet.
- 7.8 The successful bidder's completed Contractor License Information.
- 7.9 The successful bidder's completed List of Proposed Subcontractors.
- 7.10 The successful bidder's Workers Compensation Insurance Certification.
- 7.11 The successful bidder's completed Non-Collusion Declaration.
- 7.12 The successful bidder's Debarment Certification.
- 7.13 The successful bidder's completed Certificates of Insurance and Endorsements.
- 7.14 The successful bidder's executed Performance Bond.
- 7.15 The successful bidder's executed Payment Bond.
- 7.16 Executed Escrow for Deposit Agreement, if applicable.
- 7.17 Change Order Form.
- 7.18 The Maintenance Bond form included in the bid package that the Contractor must execute prior to release of final payment under the Contract.
- 7.19 The successful bidder's Qualification Statement, if any.
- 7.20 The successful bidder's signed Signature Form.

- 8. PROVISIONS INCORPORATED BY REFERENCE. Provisions or parts of provisions that are incorporated by reference and not set forth at length in any of the Contract Documents will only form a part of this Agreement to the extent the Contract Documents expressly make such provisions or parts of provisions a part of this Agreement. For example, published public works agreement provisions, such as those of the State of California Department of Transportation Standard Specifications (known as the Standard Specifications) are only a part of this Agreement

to the extent expressly incorporated in this Agreement by section number, and references in the Standard Specifications incorporated by reference to other Standard Specifications do not make such other Standard Specifications a part of this Agreement. When such published provisions are made a part of this Agreement, references in the published provisions to other entities, such as the State, the Agency, or similar references, will be deemed references to the District as the context of this Agreement may require.

9. INTERPRETATION OF CONTRACT DOCUMENTS. Any question concerning the intent or meaning of any provision of the Contract Documents, including, but not limited to, the Technical Specifications or Project Plans, must be submitted to the District, for issuance of an interpretation and/or decision by an authorized District representative in accordance with the requirements of the Contract Documents. Interpretations or decisions by any other person concerning the Contract Documents will not be binding on the District. The decision of an authorized District representative shall be final.
10. ASSIGNMENT PROHIBITED. The Contractor may not assign part or all of this agreement, or any moneys due or to become under this agreement, or any other right or interest of the Contractor under this agreement, or delegate any obligation or duty of the Contractor under this agreement without the prior written approval of an official authorized to bind the District and an authorized representative of Contractor's surety or sureties. Any such purported assignment or delegation without such written approval on behalf of the District and the Contractor's sureties will be void and a material breach of this agreement subject to all available remedies under this agreement and at law and equity.
11. CERTIFICATION RE CONTRACTOR'S LICENSE. By signing this Agreement the Contractor certifies that the Contractor holds a valid Type A license issued by the California State Contractors Licensing Board, and that the Contractor understands that failure to maintain its license in good standing throughout the performance of the Work may result in discipline and/or other penalties pursuant to the California Business and Professions Code, and may constitute a material breach of this agreement subject to all available remedies under this agreement and at law and equity.
12. SEVERABILITY. If any term or provision or portion of a term or provision of this Agreement is declared invalid or unenforceable by any court of lawful jurisdiction, then the remaining terms and provisions or portions of terms or provisions will not be affected thereby and will remain in full force and effect.

Executed on _____, _____, by

CONTRACTOR

HIDDEN VALLEY LAKE COMMUNITY
SERVICES DISTRICT

By: _____

By: _____

Title: _____

Title: President, Board of Directors

[Attach Notary Page]

Attest:

By: _____

Title: Clerk of the Board

PERFORMANCE BOND

(NOTE: Bidders must use this form, use of any other bond form may render a bid non-responsive)

KNOW ALL MEN BY THESE PRESENTS:

WHEREAS the Board of Directors of the Hidden Valley Lake Community Services District has awarded to _____ (designated as the “PRINCIPAL”) a contract for the **WWTP Access Road Improvements Project**, which contract and all of the contract documents as defined therein (designated as the “Contract”) are hereby made a part hereof; and

WHEREAS, said PRINCIPAL is required under the terms of the Contract to furnish a bond for the faithful performance of the Contract;

NOW, THEREFORE, WE, the PRINCIPAL and _____ as surety (designated as “SURETY”), an admitted surety insurer authorized to do business in the State of California, are held and firmly bound unto the District (designated as “OBLIGEE”), in the penal sum of _____ dollars (\$ _____), lawful money of the United States for the payment of which sum well and truly to be made, we bind ourselves, our heirs, executors, and administrators, and successors, jointly and severally, firmly by these presents.

THE CONDITION OF THIS OBLIGATION IS SUCH that, if the above bound PRINCIPAL, his or its heirs, executors, administrators, successors, or assigns, shall in all things stand to and abide by, and well and truly keep and perform the covenants, conditions and agreements in the Contract and any alteration thereof made as therein provided, on his or their part to be kept and performed at the time and in the manner therein specified and in all respects according to their true intent and meaning, and shall defend, indemnify and save harmless the OBLIGEE, it’s officials, officers, employees, volunteers and agents, as therein stipulated, then this obligation shall become null and void, otherwise it shall be and remain in full force and virtue.

And the said SURETY, for value received, hereby stipulates and agrees that no change, extension of time, alteration or addition to the terms of the Contract or to the work to be performed thereunder or to the specifications or the plans accompanying the same or to any other part of the contract documents, as defined therein, shall in any way affect said SURETY’s obligation on this bond, and the SURETY does hereby waive notice of any such change, extension of time, alteration or addition.

And the said SURETY, for value received, hereby stipulates and agrees that upon termination of the Contract for cause, the OBLIGEE reserves the right to refuse tender of the PRINCIPAL by the SURETY to complete the Contract work.

IN WITNESS WHEREOF, the above-bound parties have executed this instrument under their several seals this _____ day of _____, _____, the name and corporate seals of each corporate party being hereto affixed and these presents duly signed by their undersigned representatives, pursuant to authority of their governing bodies.

(Corporate Seal) PRINCIPAL _____

By _____

(Acknowledgment) Title _____

(Corporate Seal) SURETY _____

By _____
(Attorneys-in-fact)

(Acknowledgment) Title _____

(NOTE TO SURETY COMPANY: A certified copy of unrevoked resolution of authority for the attorney-in-fact must be submitted with and attached to the executed bond.)

PAYMENT/LABOR AND MATERIALS BOND

(NOTE: Bidders must use this form, use of any other bond form may render a bid non-responsive)

KNOW ALL MEN BY THESE PRESENTS:

WHEREAS the Board of Directors of the Hidden Valley Lake Community Services District has awarded to _____ (designated as the “PRINCIPAL”) a contract for the **WWTP Access Road Improvements Project**, which contract and all of the contract documents as defined therein (designated as the “Contract”) are hereby made a part hereof; and

WHEREAS, pursuant to California Civil Code Section 9550, the PRINCIPAL is required, before entering upon the performance of the Contract, to file a payment bond with and have such bond approved by the officer or public entity by whom the Contract is awarded; and

WHEREAS, pursuant to California Civil Code Section 9554, such payment bond must be in a sum not less than one hundred percent (100%) of the total amount payable by the terms of the Contract, and must satisfy the other requirements specified in that section; and

WHEREAS, the PRINCIPAL is required in accordance with the Contract to furnish a payment bond in connection with the Contract to secure payment of claims of laborers, mechanics and materialmen employed on work under the Contract in accordance with applicable law;

NOW, THEREFORE, THESE PRESENTS WITNESSETH:

That the PRINCIPAL and the undersigned _____, as surety (designated as “SURETY”), an admitted surety insurer authorized to do business in the State of California are held and firmly bound unto all laborers, material men, and all other persons named in California Civil Code Section 9100 in the sum of _____ Dollars (\$ _____), lawful money of the United States, being a sum not less than one hundred percent of the total amount payable by the terms of the Contract, for the payment of which sum well and truly to be made, we bind ourselves, our heirs, executors, administrators, successors, or assigns, jointly and severally, by these presents.

THE CONDITION OF THIS OBLIGATION IS SUCH that if the PRINCIPAL or any of the PRINCIPAL’s subcontractors, or the heirs, executors, administrators, successors, or assigns of any, all, or either of them, shall fail to pay any persons named in California Civil Code Section 9100, or fail to pay for any labor, materials, provisions, provender, or other supplies used in, upon, for or about the performance of the work contracted to be done, or for any work or labor thereon of any kind, or fail to pay amounts due under the Unemployment Insurance Code with respect to such work or labor, or fail to pay for any amounts required to be deducted, withheld, and paid over to the Employment Development Department from the wages of employees of the PRINCIPAL or any subcontractors of the PRINCIPAL pursuant to Section 13020 of the Unemployment Insurance Code with respect to such work or labor, that the SURETY will pay for the same in an amount not exceeding the amount herein above set forth, and also, in case suit is brought upon this bond, will pay a reasonable attorney’s fee to be awarded and fixed by the Court; otherwise this obligation shall be void.

It is hereby expressly stipulated and agreed by the said Surety, for value received, that this bond shall inure to the benefit of any and all of the persons named in Section 9100 of the California Civil Code so as to give a right of action to them or their assigns in any suit brought upon this bond.

It is hereby further expressly stipulated and agreed by the said Surety, for value received, that no change, extension of time, alteration or addition to the terms of the Contract or the specifications or drawings accompanying the same or to any other part of the contract documents, as defined therein, shall in any manner affect the obligations of the SURETY on this bond, and SURETY does hereby waive notice of any such change, extension, alteration, or addition.

IN WITNESS WHEREOF, the above-bound parties have executed this instrument under their several seals this _____ day of _____, _____, the name and corporate seals of each corporate party being hereto affixed and these presents duly signed by their undersigned representatives, pursuant to authority of their governing bodies.

(Corporate Seal) PRINCIPAL _____

By _____

(Acknowledgment) Title _____

(Corporate Seal) SURETY _____

By _____
(Attorneys-in-fact)

(Acknowledgment) Title _____

(NOTE TO SURETY COMPANY: A certified copy of unrevoked resolution of authority for the attorney-in-fact must be submitted with and attached to the executed bond.)

HIDDEN VALLEY LAKE COMMUNITY SERVICES DISTRICT

19400 Hartmann Rd., Hidden Valley Lake, CA 95467

ORDER NO
DATE
STATE California
COUNTY Lake

CONTRACT CHANGE ORDER

CONTRACT FOR: WWTP Access Road Improvement Project

CONTRACT NO:

OWNER: Hidden Valley Lake Community Services District

CONTRACTOR:

CURRENT CONTRACT PRICE:

CURRENT CONTRACT TIME OF COMPLETION:

CURRENT NO. WORKING DAYS

TO:

(Contractor)

You are hereby requested to comply with the following changes from to the contract plans, specifications, or other contract documents:

Description of Changes (Supplemental Plans and Specifications Attached)	DECREASE in Contract Price	INCREASE In Contract Price
1)		
TOTALS	\$ -	\$ -
NET CHANGE IN CONTRACT PRICE	\$ 0.00	

JUSTIFICATION:

The amount of the Contract will be (Decreased) (Increased) By The Sum Of:

\$
-

The Contract Total Including this and previous Change Orders Will Be:

The Contract Period Provided for Completion Will Be (Increased) (Decreased) (Unchanged): _____ Days
Contract
Completion Date

Upon execution by representatives authorized to bind the parties, this Change Order will become a part of the contract. The consideration specified in this Change Order (whether an adjustment of the contract price, an adjustment of time, and/or other consideration) is the full and sole compensation owed to the contractor as a result of the changes and issues described in this Change Order. Such consideration includes, but is not limited to, any and all direct and indirect costs incurred by the contractor as a result of the changes and issues described in this Change Order for any labor, equipment, materials, overhead (additional, extended, field and home office), profit, or time adjustments. By signing this Change Order the contractor waives and releases the owner from any and all claims for additional compensation concerning any of the changes and issues specified in this Change Order.

The undersigned, being the _____ (Title) of the Contractor, by signing this Changer Order declares under penalty of perjury under the laws of the State of California, and does personally certify and attest that: the undersigned has thoroughly reviewed the attached request for change order and knows its contents, and said request for change order is made in good faith; that it is supported by truthful and accurate data; that the amount requested and the additional time requested accurately reflect the allowable expenses that would be incurred, and the time necessary, to perform the change order; and further, that the undersigned is familiar with California Penal Code Section 72 and California Government Code Section 12650 et seq., pertaining to false claims, and further knows and understands that the submission or certification of a false claim may lead to fines, imprisonment, or other severe legal consequences.

Requested _____ (Owner) (Date)

Recommended _____ (Owner's Architect/Engineer) (Date)

Accepted _____ (Contractor) (Date)

Approved by Agency _____ (Name and Title) (Date)

925984

MAINTENANCE BOND

(NOTE: Bidders must use this form, use of any other bond form may render a bid non-responsive)

KNOW ALL MEN BY THESE PRESENTS:

WHEREAS the Board of Directors of the Hidden Valley Lake Community Services District has awarded to _____ (designated as the "PRINCIPAL") a contract for the **WWTP Access Road Improvements Project** which contract and all of the contract documents as defined therein (designated as the "Contract") are hereby made a part hereof; and

WHEREAS, the PRINCIPAL is required under the terms of the Contract to furnish a bond for the correction of any defects due to defective materials or workmanship in the work performed under the Contract.

NOW, THEREFORE, we the PRINCIPAL and the undersigned _____, as surety (designated as "SURETY"), an admitted surety insurer authorized to do business in the State of California, are held and firmly bound unto the Hidden Valley Lake Community Services District, (designated as the "OBLIGEE"), in the penal sum of _____ Dollars (\$ _____), lawful money of the United States, being a sum not less than twenty percent (20%) of the final Contract price, for the payment of which sum well and truly to be made, we bind ourselves, our heirs, executors, administrators, successors, and assigns jointly and severally, firmly by these presents.

THE CONDITIONS OF THIS OBLIGATION ARE SUCH that if, during a maintenance period of one (1) year from the date of acceptance by the OBLIGEE of the contracted work, the PRINCIPAL upon receiving written notice of a need for repairs which are directly attributable to defective materials or workmanship, shall diligently take the necessary steps to correct said defects within seven (7) days from the date of said notice, then this obligation shall be null and void; otherwise it shall remain in full force and effect.

If any action shall be brought by the OBLIGEE upon this bond, a reasonable attorney's fee, to be fixed by the Court, shall be and become a part of OBLIGEE's judgment in any such action.

No right of action shall accrue on this bond to, or for the use of, any person or corporation other than the OBLIGEE named herein or the heirs, executors, administrator or successor of the OBLIGEE.

IN WITNESS WHEREOF, the above bound parties have executed this instrument under their seals this _____ day of _____, the name and corporate seals of each corporate party being hereto affixed and these presents duly signed by its undersigned representative, pursuant to authority of its governing body.

(Corporate Seal) PRINCIPAL _____

By _____

(Acknowledgment) Title _____

(Corporate Seal)

SURETY _____

By _____
(Attorneys-in-fact)

(Acknowledgment)

Title _____

(NOTE TO SURETY COMPANY: A certified copy of unrevoked resolution of authority for the attorney-in-fact must be submitted with and attached to the executed bond.)

**ESCROW AGREEMENT FOR
SECURITY DEPOSITS IN LIEU OF RETENTION**

This Escrow Agreement is made and entered into by and between the Hidden Valley Lake Community Services District, whose address is 19400 Hartmann Rd., Hidden Valley Lake, California 945467 hereinafter called "District", and _____, hereinafter called "Contractor", whose address is _____ and _____, whose address is _____, hereinafter called "Escrow Agent"

For consideration hereinafter set forth, the District, Contractor, and Escrow Agent agree as follows:

1. Pursuant to Section 22300 of the Public Contract Code of the State of California, Contractor has the option to deposit securities with Escrow Agent as a substitute for retention earnings required to be withheld by District pursuant to the Construction Contract entered into between the District and Contractor for the project entitled **WWTP Access Road Improvements Project** in the amount of _____ dated _____ (hereinafter referred to as the "Contract"). Alternatively, on written request of the Contractor, the District shall make payments of the retention earnings directly to the Escrow Agent. When Contractor deposits the securities as substitute for Contract earnings, the Escrow Agent shall notify the District within 10 days of the deposit. The market value of the securities at the time of the substitution shall be at least equal to the cash amount then required to be withheld as retention under the terms of the Contract between the District and Contractor. Securities shall be held in the name of _____ and shall designate the Contractor as the beneficial owner.
2. The District shall make progress payments to the Contractor for such funds which otherwise would be withheld from progress payments pursuant to the Contract provisions, provided that the Escrow Agent holds securities in the form and amount specified above.
3. When the District makes payment of retentions earned directly to the Escrow Agent, the Escrow Agent shall hold them for the benefit of the Contractor until such time as the escrow created under this contract is terminated. The Contractor may direct the investments of the payments into securities. All terms and conditions of this agreement and the rights and responsibilities of the parties shall be equally applicable and binding when the District pays the escrow agent directly.
4. Contractor shall be responsible for paying all fees for the expenses incurred by Escrow Agent in administering the Escrow Account and all expenses of the District. These expenses and payment terms shall be determined by the District, Contractor and Escrow Agent.
5. The interest earned on the securities or the money market accounts held in escrow and all interest earned on that interest shall be for the sole account of the Contractor and shall be subject to withdrawal by Contractor at any time and from time to time without notice to the District.
6. Contractor shall have the right to withdraw all or any part of the principal in the Escrow Account only by written notice to Escrow Agent accompanied by written authorization from District to the Escrow Agent that District consents to the withdrawal of the amount sought to be withdrawn by Contractor.
7. The District shall have a right to draw upon the securities in the event of default by the Contractor. Upon seven day's written notice to the Escrow Agent from the District of the default, the Escrow Agent shall immediately convert the securities to cash and shall distribute the cash as instructed by the District.

8. Upon receipt of written notification from the District certifying that the Contract is final and complete, and that the Contractor has complied with all requirements and procedures applicable to the Contract, Escrow Agent shall release to Contractor all securities and interest on deposit less escrow fees and charges of the Escrow Account. The escrow shall be closed immediately upon disbursement of all monies and securities on deposit and payments of fees and charges.
9. Escrow Agent shall rely on the written notifications from the District and the Contractor pursuant to Sections (4) to (6) inclusive, of this agreement and the District and Contractor shall hold Escrow Agent harmless from Escrow Agent's release and disbursement of the securities and interest as set forth above.
10. The names of the persons who are authorized to give written notice or to receive written notice on behalf of the District and on behalf of Contractor in connection with the foregoing, and exemplars of their respective signatures, are as follows:

On behalf of District:

Title: _____

Name: _____

On Behalf of Contractor:

Title: _____

Name: _____

On behalf of Escrow Agent:

Title

Name

Signature

Address

At the time the Escrow Account is opened, the District and Contractor shall deliver to the Escrow Agent a fully executed counterpart of this Agreement.

IN WITNESS WHEREOF, the parties have executed this Agreement by their proper officers on the date first set forth above.

District:

Contractor:

Title

Title

Name

Name

Signature

Signature

Address

Address

GENERAL PROVISIONS

SECTION 1 DEFINITIONS

The following terms as used in any agreement of which these General Provisions are a part are defined as follows:

- 1-1.01 Agreement:** The agreement between the District and Contractor concerning the Project, as evidenced by and comprised of the Contract Documents.
- 1-1.02 Base:** A layer of specified material of planned thickness placed immediately below the pavement or surfacing.
- 1-1.03 Base Material:** The material in excavation or embankments underlying the lowest layer of subbase, base, pavement, surfacing or other specified layer which is to be placed.
- 1-1.04 Bid Package:** All of the documents listed as comprising the entire Bid Package as specified in the Instructions to Bidders and representing the full set of documents made available to bidders on the Project.
- 1-1.05 Bridge:** Any structure, with a bridge number, which carries a utility facility, or railroad, highway, pedestrian or other traffic, over a water course or over or under or around any obstruction.
- 1-1.06 Caltrans:** The Department of Transportation of the State of California, as created by law.
- 1-1.07 Change Order:** Amendment to the Agreement, the Project Plans, Technical Specifications or other Contract Documents in accordance with Section 3, Control of Work and Material and Changes in Work, of the General Provisions.
- 1-1.08 District:** Hidden Valley Lake Community Services District.
- 1-1.09 Conduit:** A pipe or tube in which smaller pipes, tubes or electrical conductors are inserted or are to be inserted.
- 1-1.10 Contract Documents:** All those documents listed in the Project agreement as comprising the entire agreement between the District and the Contractor.
- 1-1.11 Contractor:** The successful bidder for the Project and party to the Project agreement with the District as specified in the Project agreement.

- 1-1.12 Culvert:** Any structure, other than a bridge, which provides an opening under a roadway for drainage or other purposes.
- 1-1.13 Days:** Unless otherwise specified in the Contract Documents, days mean working days.
- 1-1.14 Designer:** The person or persons so specified on the Technical Specifications and/or Project Plans.
- 1-1.15 Detour:** A temporary route for traffic around a closed portion of a road.
- 1-1.16 Divided Highway:** A highway with separated traveled ways for traffic, generally in opposite directions.
- 1-1.17 Engineer:** The District's authorized representative for administration and overall management of the Project agreement and Work. The Engineer is the official point of contact between the District and the Contractor.
- 1-1.18 Frontage Road:** A local street or road auxiliary to and located generally on the side of an arterial highway for service to abutting property and adjacent areas and for control of access.
- 1-1.19 Grading Plane:** The surface of the basement material upon which the lowest layer of subbase, base, pavement, surfacing or other specified layer is placed.
- 1-1.20 Highway:** The whole right of way or area which is reserved for and secured for use in constructing the roadway and its appurtenances.
- 1-1.21 Laboratory:** The established laboratory of the Materials and Research Department of the Department of Transportation of the State of California or laboratories authorized by the Engineer to test materials involved in the contract.
- 1-1.22 Manual on Uniform Traffic Control Devices:** The latest edition of the California Manual on Uniform Traffic Control Devices.
- 1-1.23 Median:** That portion of a divided highway separating the traveled ways for traffic in opposite directions including inside shoulders.
- 1-1.24 Office of Structure Design:** The Offices of Structure Design of the Department of Transportation. When the specifications require working drawings to be submitted to the Offices of Structure Design, the drawings shall be submitted to: Offices of Structure Design, Documents Unit, Mail Station 9-4/4I, 1801 30th Street, Sacramento, CA 95816, Telephone (916) 227-8252.
- 1-1.25 Pavement:** The uppermost layer of material placed on the traveled way or shoulders. This term is used interchangeably with surfacing.

- 1-1.26 Processing:** Any operation or operations of whatever nature and extent required to produce a specified material.
- 1-1.27 Project:** The **Wastewater Treatment Plant Access Road & Pond Levee Repairs** as described in the Technical Specifications and Project Plans.
- 1-1.28 Project Inspector:** The party or parties charged by the District with inspecting the Work for compliance with the requirements of the Contract Documents and applicable laws and regulations. The Project Inspector acts under the direction of the District and shall coordinate with the District as directed by the District in accordance with the Contract Documents.
- 1-1.29 Project Plans:** The primarily graphic detailed requirements concerning the Project contained in the Bid Package and any addenda to the Project Plans signed by authorized District representatives and issued prior to bid opening, Equal Product Proposals accepted by the District and signed by authorized District representatives prior to bid opening, and change orders and other amendments to the Project Plans signed by authorized representatives of the District and the Contractor in accordance with the requirements of the Contract Documents.
- 1-1.30 Roadbed:** The roadbed is that area between the intersection of the upper surface of the roadway and the side slopes or curb lines. The roadbed rises in elevation as each increment or layer of subbase, base, surfacing or payment is placed. Where the medians are so wide as to include areas of undisturbed land, a divided highway is considered as including 2 separate roadbeds.
- 1-1.31 Roadway:** That portion of the highway included between the outside lines of sidewalks, or curbs, slopes, ditches, channels, waterways, and including all the appertaining structures, and other features necessary to proper drainage and protection.
- 1-1.32 Shoulders:** The portion of the roadway contiguous with the traveled way for accommodation of stopped vehicles, for emergency use, and for lateral support of base and surface courses.
- 1-1.33 Special Provisions:** The special provisions set forth conditions or requirements peculiar to the Work and supplementary to the General Provisions.
- 1-1.34 Standard Specifications:** The directions, provisions and requirements contained in the Caltrans Specifications.
- 1-1.35 Subbase:** A layer of specified material of planned thickness between a base and the basement material.
- 1-1.36 Subcontractor:** A person, firm or corporation that is obligated as a party to a contract with the Contractor to perform part of the Project work. For purposes of

these General Provisions Subcontractors include, but are not limited to, those that are obligated as parties to a contract with the Contractor to specially fabricate and install a portion of the Project Work according to the Technical Specifications and/or Project Plans.

1-1.37 Subgrade: That portion of the roadbed on which pavement, surfacing, base, subbase, or a layer of any other material is placed.

1-1.38 Substructure: All that part of the bridge below the bridge seats, tops of piers, haunches of rigid frames, or below the spring lines of arches. Backwalls and parapets of abutments and wingwalls of bridges shall be considered as parts of the substructure.

1-1.39 Superstructure: All that part of the bridge except the bridge substructure.

1-1.40 Surfacing: The uppermost layer of material placed on the traveled way, or shoulders. This term is used interchangeably with pavement.

1-1.41 Technical Specifications: The detailed Project requirements contained in the Bid Package and any addenda to the Technical Specifications signed by authorized District representatives and issued prior to bid opening, Equal Product Proposals accepted by the District and signed by authorized District representatives prior to bid opening, and change orders and other amendments to the Technical Specifications signed by authorized representatives of the District and the Contractor in accordance with the requirements of the Contract Documents.

1-1.42 Traffic Lane: That portion of a traveled way for the movement of a single line of vehicles.

1-1.43 Traveled Way: That portion of the roadway for the movement of vehicles, exclusive of the shoulders.

1-1.44 Work: The furnishing of all equipment, tools, apparatus, facilities, material, labor and skill necessary to perform and complete in a good and workmanlike manner the Project as shown in the Technical Specifications and Project Plans in accordance with the Contract Documents and applicable law.

1-1.45 Written Notice: Will be deemed to have been duly served for purposes of these General Provisions and any agreement of which they are a part if delivered in person to the individual or to a member of the firm or to any office of the corporation for whom the notice is intended, or if sent by registered or certified mail to the last known business address known to the party giving notice. Unless otherwise specified in the Contract Documents, the last known address of the Contractor shall be that listed in the Contractor's completed Proposal and Schedule of Bid Prices.

SECTION 2

SCOPE OF WORK

2-1.01 Documents Furnished by District. The District will furnish to the Contractor, free of charge three (3) sets of prints of the Project Plans and Technical Specifications for execution of the Work. Throughout the performance of the Work the Contractor must keep one copy of the Project Plans and Technical Specifications in good order and available for review by the Engineer, the Designer, and any other District contractors or representatives.

2-1.02 Ownership of Documents Furnished by District. All documents furnished by the District, including, but not limited to, the Technical Specifications, Project Plans, and any copies, are the property of the District. Documents furnished by the District may not to be used on any other work. All documents furnished by the District must be returned to District upon completion of the Work.

2-1.03 Technical Specifications and Project Plans.

- a. The Technical Specifications and Project Plans are complementary and intended to mutually describe the Work necessary to complete the Project in accordance with the Contract Documents.
- b. In general, the Project Plans indicate dimensions, position and kind of construction, and the Technical Specifications indicate qualities and methods. Any Work indicated on the Project Plans and not mentioned in the Technical Specifications or vice versa must be furnished as though fully set forth in both. Work that is not particularly detailed, marked or specified shall be the same as similar Work that is detailed, marked or specified. The Contractor must furnish items necessary for the operation of equipment depicted in the Project Plans or specified in the Technical Specifications that are suitable to allow such equipment to function properly at no extra charge.
- c. The Contractor must notify the Engineer as soon as possible of any apparent errors or inconsistencies, including, but not limited to, typographical or notational errors in the Project Plans, Technical Specifications, and/or in work done by others affecting the Work. The Engineer will issue instructions concerning any such apparent errors or inconsistencies. If the Contractor proceeds with Work impacted by apparent errors or inconsistencies without instructions from the Engineer, the Contractor shall do so at its sole risk and shall have all of the obligations and the District shall have all of the rights and remedies specified in Section 9 concerning any resulting damage or defect.
- d. The General Provisions apply with equal force to all of the Work, including extra work authorized by the Engineer in accordance with the Contract Documents. The Contractor must submit any required shop diagrams and/or

drawings by the times and in the quantities indicated in the Technical Specifications. Any such shop diagrams and/or drawings must show completely the Work to be done, expanding on the Project Plans concerning details not previously shown, field conditions and the condition of the Work. Engineer review of such shop diagrams and/or drawings will concern conformance with the requirements of the Contract Documents only. The Engineer assumes no responsibility for the correctness or accuracy of the dimensions or any other contents of any shop diagrams and/or drawings submitted by the Contractor. The Contractor must check all dimensions at the Work site. Shop diagrams and/or drawings must be clearly marked with the name of the Project and the name of the Contractor, subcontractor or supplier making the submittal, and must be stamped and signed by the Contractor and submitted under a signed transmittal letter from the Contractor certifying that all dimensions have been checked at the Work site. These requirements are mandatory. The Engineer will not review shop diagrams and/or drawings that do not satisfy these requirements. The Contractor will be responsible for any and all discrepancies between dimensions of the actual Project site and/or Work and those shown on shop diagram and/or drawings submitted by the Contractor, and for any other errors contained in or resulting from such shop diagrams and/or drawings, including, but not limited to, errors in material and/or equipment quantities and any resulting errors, delays or additional cost in the performance of the Work. The Contractor will have all of the obligations and the District will have all of the rights and remedies that are specified in Section 9, Remedies and Disputes, concerning any discrepancies or errors in shop diagrams and/or drawings submitted by the Contractor, and concerning any resulting errors, delays or additional costs in the performance of the Work.

2-1.04 Pre-Construction Conference. Prior to the issuance of the Notice to Proceed, a pre-construction conference will be held at the Office of the District for the purpose of discussing with the Contractor the scope of work, Contract drawings, specifications, existing conditions, materials to be ordered, equipment to be used, and all essential matters pertaining to the prosecution of and the satisfactory completion of the project as required. The Contractor's representative at this conference shall include all major superintendents for the work and may include major subcontractors.

SECTION 3 CONTROL OF WORK AND MATERIAL AND CHANGES IN THE WORK

3-1.01 Engineer's Status. The Engineer will administer the Project in accordance with the Contract Documents. After execution of the agreement and issuance of the Notice to Proceed, all correspondence and/or instructions concerning the Project between the Contractor and/or District shall be forwarded through the Engineer. Except as otherwise provided in the Contract Documents, the Engineer will not be responsible for and will not have control or charge of construction means, methods, techniques, or procedures or for safety precautions in connection with the Work. The Engineer, however, will have authority to reject materials and/or workmanship that do not conform to the requirements of the Contract Documents. The Engineer will also have the authority to require inspection or testing of the Work.

3-1.02 Designer's Status. The Designer will advise the Engineer concerning decisions on all claims of the Contractor and all other matters relating to the execution and progress of the Work or the interpretation of the Contract Documents. The Designer will also advise the Engineer concerning Work that does not conform to the Contract Documents. Whenever, in the Designer's opinion, it is necessary or advisable in accordance with the Contract Documents, the Designer may recommend to the Engineer inspection or testing of the Work, whether or not such Work is then fabricated, installed or completed.

3-1.03 Inspection and Testing of Work and Material.

- a. The District, the Engineer, the Designer and their representatives will have access to the Work at all times wherever it is in preparation or progress. The Contractor must provide proper facilities for such access and for inspection. The Contractor shall furnish the Engineer a list of the Contractor's sources of materials and the locations at which those materials will be available for inspection. The list shall be furnished to the Engineer in sufficient time to permit inspecting and testing of materials to be furnished from the listed sources in advance of their use. Within three (3) business days of receipt of the list, the Engineer may inspect, sample or test materials at the source of supply or other locations, but the inspection, sampling or testing will not be undertaken until the Engineer is assured by the Contractor of the cooperation and assistance of both the Contractor and the supplier of the material. The Contractor shall assure that the Engineer or the Engineer's authorized representative has free access at all times to the material to be inspected, sampled or tested. Adequate facilities shall be furnished free of charge to make the necessary inspection. The District assumes no obligation to inspect materials at the source of supply. It is understood that the inspections and tests if made at any point other than the point of incorporation in the Work in no way shall be considered as a guaranty

of acceptance of the material nor of continued acceptance of material presumed to be similar to that upon which inspections and tests have been made, and that inspection and testing performed by the District shall not relieve the Contractor or the Contractor's suppliers of responsibility for quality control.

- b. The Contractor must inspect all materials as delivered and promptly return all defective materials without waiting for their rejection by the Designer or Engineer. The Contractor shall be responsible for controlling the quality of the material entering the Work and of the Work performed, and shall perform testing as necessary to ensure control. The test methods used for quality control testing shall be as determined by the Contractor and this Agreement. The results of the testing shall be made available to the Engineer upon request. These tests are for the Contractor's use in controlling the Work and will not be accepted for use as acceptance tests. Full compensation for performing quality control tests and making the results available to the Engineer shall be considered as included in the Contract Prices and no additional compensation will be allowed therefore.
- c. If the Engineer, the Technical Specifications, or any laws, ordinances, or any public authority require any Work to be tested or approved, the Contractor must give the Engineer timely notice of the Contractor's readiness for inspection. Inspections will be promptly made, and where practicable, at the source of supply. Any work subject to such testing that is covered up without timely notice to the Engineer or without the approval or consent of the Engineer must, if required by the Engineer, be uncovered for examination at the Contractor's expense. The Contractor will have all of the obligations and the District will have all of the rights and remedies that are specified in Section 9 concerning any work subject to testing that is covered up without timely notice to the Engineer and that is not uncovered for examination at the Contractor's expense if required by the Engineer.
- d. Tests of materials or qualification tests required by the Contract Documents must be made in accordance with the Technical Specifications and the requirements of the California Building Standards Code, where applicable, as adopted by the District, and other applicable law. Copies of all testing reports shall be distributed as required in the Technical Specifications. The laboratory or inspection agency shall be selected by the District. The District will pay for all laboratory inspection service direct, and not as a part of the contract. Materials of construction, particularly those upon which the strength and durability of the structure may depend, shall be subject to inspection and testing to establish conformance with specifications and suitability for uses intended.
- e. The District or its representatives may order re-examination of questioned Work. If ordered to do so, the Contractor must uncover such Work. If such Work is found to be according to the Contract Documents, the District shall pay the cost of uncovering and restoring the Work, unless such Work was subject to testing and covered up without timely notice to or approval of the Engineer.

If re-examined Work is found not in accordance with the Contract Documents, the Contractor must pay the cost of uncovering and restoring the Work. The Contractor will have all of the obligations and the District will have all of the rights and remedies that are specified in Section 9 concerning any re-examined Work not in accordance with the Contract Documents that the Contractor fails to uncover and restore at the Contractor's expense.

- f. The Contractor must replace or correct without charge any material or workmanship found not to conform to the requirements of the Contract Documents, unless the District consents to accept such material or workmanship with an appropriate adjustment in the Contract Price. The Contractor must promptly segregate and remove non-conforming material from the Work site. The Contractor will have all of the obligations and the District will have all of the rights and remedies that are specified in Section 9 concerning any failure by the Contractor to replace or correct without charge any material or workmanship that does not conform to the requirements of the Contract Documents and that the District has not consented to accept.
- g. Any work done beyond the lines and grades shown on the Project Plans or established by the Engineer, or any extra work done without written authority will be considered as unauthorized work and will not be paid for. Upon order of the Engineer unauthorized work shall be remedied, removed or replaced at the Contractor's expense.
- h. The inspection of the Work or materials shall not relieve the Contractor of any of the Contractor's obligations to fulfill the Agreement. Work and materials not meeting Agreement requirements shall be made good, and unsuitable Work of materials may be rejected, notwithstanding that the Work or materials have been previously inspected by the Engineer or that payment therefore has been given.
- i. Unless otherwise specified, all tests shall be performed in accordance with the methods used by Caltrans and shall be made by the Engineer or the Engineer's designated representative.
- j. The District has developed methods for testing the quality of materials and work. These methods are identified by number and are referred to in the Technical Specifications as California Tests. Copies of individual California Tests are available at the Transportation Laboratory, Sacramento, California, and will be furnished to interested persons upon request.
- k. Whenever the specifications require compliance with specified values for the following properties, tests will be made by the California Test indicated unless otherwise specified:

Properties	California Test
Relative Compaction	216 or 231
Sand Equivalent	217
Resistance (R-value)	301
Grading (Sieve Analysis)	202
Durability Index	229

- l. Whenever a reference is made in the Technical Specifications to a California Test by number, it shall mean the California Test in effect on the day the Agreement is signed on behalf of the District.
- m. Whenever the Technical Specifications provide an option between 2 or more tests, the Engineer will determine the test to be used.
- n. Whenever a reference is made in the Technical Specifications to a specification, manual or test designation either of the American Society for Testing and Materials, the American Association of State Highway and Transportation Officials, Federal Specifications or any other recognized national organization, and the number or other identification representing the year of adoption or latest revision is omitted, it shall mean the specification, manual or test designation in effect on the day the Agreement is signed on behalf of the District. Whenever the specification, manual or test designation provides for test reports (such as certified mill test reports) from the manufacturer, copies of those reports, identified as to the lot of material, shall be furnished to the Engineer. The manufacturer's test reports shall supplement the inspection, sampling and testing provisions in this Section, and shall not constitute a waiver of the District's right to inspect. When material which cannot be identified with specific test reports is proposed for use, the Engineer may, at the Engineer's discretion, select random samples from the lot for testing. Test specimens from the random samples, including those required for retest, shall be prepared in accordance with the referenced specification and furnished by the Contractor at the Contractor's expense. The number of the samples and test specimens shall be entirely at the discretion of the Engineer. Unidentified metal products, such as sheet, plate and hardware shall be subject to the requirements of Section 55-1.02A (6), "Unidentified Stock Material" of the Standard Specifications.
- o. When requested by the Engineer, the Contractor shall furnish, without charge, samples of all materials entering into the Work, and no material shall be used prior to approval by the Engineer, except as provided in Section 3-1.04, "Certificates of Compliance." Samples of material from local sources shall be taken by or in the presence of the Engineer; otherwise, such samples will not be considered for testing.

3-1.04 Certificates of Compliance.

- a. Certificates of Compliance shall be furnished prior to the use of any materials for which the Technical Specifications require that a certificate be furnished. In addition, when so authorized in the Technical Specifications, the Engineer may permit the use of certain materials or assemblies prior to sampling and testing if accompanied by a Certificate of Compliance. The certificate shall be signed by the manufacturer of the material or the manufacturer of assembled materials and shall state that the materials involved comply in all respects with the requirements of the Technical Specifications. A Certificate of Compliance shall be furnished with each lot of material delivered to the work and the lot so certified shall be clearly identified in the certificate.
- b. Materials used on the basis of a Certificate of Compliance may be sampled and tested at any time. The fact that material is used on the basis of a Certificate of Compliance shall not relieve the Contractor of responsibility for incorporating material in the Work which conforms to the requirements of the Project Plans and Technical Specifications, and any material not conforming to the requirements will be subject to rejection whether in place or not.
- c. The District reserves the right to refuse to permit the use of material on the basis of a Certificate of Compliance.
- d. The form of the Certificate of Compliance and its disposition shall be as directed by the Engineer.

3-1.05 Samples Furnished by the Contractor. The Contractor must furnish all samples for approval as directed in sufficient time to permit the Designer or Engineer to examine, approve and select samples before they are required by the progress of the Work. Portions of the Work for which samples are required and for which the Designer or Engineer has selected samples must be in accordance with such approved samples. Samples must be sent prepaid to the office of the Engineer or to such place as the Engineer may direct.

3-1.06 Materials and Substitutions.

- a. Materials used for the Work must be new and of the quality specified. When not particularly specified, materials must be the best of their class or kind. The Contractor must, if required, submit satisfactory evidence as to the kind and quality of materials.
- b. If the Contractor submitted complete information to the District for products proposed as equals in accordance with the bid package, and the District approved such products proposed as equals in writing, the Contractor may either furnish such products approved as equals, or furnish the products listed by manufacturer name, brand or model number in the Technical Specifications

or Project Plans. The District retains the right, in its sole discretion, to accept or reject any other proposed substitution. To be considered, proposals concerning products proposed as equals must include sufficient information to permit the District to determine whether the products proposed as equals will satisfy the same performance requirements as products listed by manufacturer's name, brand or model number. Such performance requirements may include, but are not limited to, size, strength, function, appearance, ease of maintenance and repair, and useful life requirements. If the District does not accept a proposed substitution, the Contractor must furnish the product specified in the Technical Specifications or Project Plans for the Contract Price, regardless of whether the product is specified by manufacturer's name, brand or model number, or otherwise.

3-1.07 Contractors Responsibility For The Work And Materials.

- a. Until the acceptance of the Work, the Contractor shall have the charge and care of the Work and of the materials to be used and shall bear the risk of injury, loss or damage to any part thereof by the action of the elements or from any other cause, whether arising from the execution or from the non-execution of the Work, except as provided in Sections 6-1.16, "Public Convenience," and 5-1.11, "Relief From Maintenance and Responsibility." The Contractor shall rebuild, repair, restore, and make good all injuries, losses or damages to any portion of the Work or the materials occasioned by any cause before its completion and acceptance and shall bear the expense thereof, except for those injuries, losses, or damages that are directly and proximately caused by acts of the Federal Government or the public enemy. Where necessary to protect the Work or materials from damage, the Contractor shall, at the Contractor's expense, provide suitable drainage of the roadway and erect those temporary structures that are necessary to protect the Work or materials from damage. The suspension of the Work from any cause whatever shall not relieve the Contractor of the responsibility for the Work and materials as herein specified. If ordered by the Engineer, the Contractor shall, at the Contractor's expense, properly store materials which have been partially paid for by the District or which have been furnished by the District. Storage by the Contractor shall be on behalf of the District and the District shall at all times be entitled to the possession of the materials, and the Contractor shall promptly return the materials to the site of the Work when requested. The Contractor shall not dispose of any of the materials so stored except on written authorization from the Engineer.
- b. During the performance of the Work, all materials must be neatly stacked, properly protected from the weather and other adverse impacts, and placed so as to avoid interference with efficient progress of the Work, with other activities of the District, or with the use of existing District facilities by the public. All materials must be delivered so as to ensure efficient and uninterrupted progress of the Work. Materials must be stored so as to cause no obstruction and so as

to prevent overloading of any portion of the Work. The Contractor will be responsible for damage or loss of materials delivered to and/or stored at the Work site due to weather or other causes. The Contractor must promptly remove from the Work site all materials rejected by the District or its representatives as failing to conform to the requirements of the Contract Documents, whether such non-conforming materials have been incorporated in the Work or not. If the District or its representatives so direct, the Contractor must promptly replace and re-execute Work performed by the Contractor and order the replacement and re-execution of Work performed by subcontractors using non-conforming materials with materials that satisfy the requirements of the Contract Documents without expense to the District. The Contractor will bear the expense of making good all Work destroyed or damaged by such removal. The Contractor will have all of the obligations and the District will have all of the rights and remedies that are specified in Section 9 concerning any failure by the Contractor to replace or re-execute Work using non-conforming materials, and/or to make good all work destroyed or damaged by such removal and/or execution.

3-1.08 Audit and Examination of Records. The District may examine and audit at no additional cost to the District all books, estimates, records, contracts, documents, bid documents, bid cost data, subcontract job cost reports and other Project related data of the Contractor, subcontractors engaged in performance of the Work, and suppliers providing supplies, equipment and other materials required for the Work, including computations and projections related to bidding, negotiating, pricing or performing the Work or contract modifications and other materials concerning the Work, including, but not limited to, Contractor daily logs, in order to evaluate the accuracy, completeness, and currency of cost, pricing, scheduling and any other project related data. The Contractor will make available all such Project related data at all reasonable times for examination, audit, or reproduction at the Contractor's business office at or near the Work site, and at any other location where such Project related data may be kept until three years after final payment under the Agreement. Pursuant to California Government Code Section 8546.7, if the amount of public funds to be expended is in excess of \$10,000, this Agreement shall be subject to the examination and audit of the State Auditor, at the request of the District, or as part of any audit of the District, for a period of three (3) years after final payment under the Agreement.

3-1.09 Advertising. No advertising signs of any kind may be displayed on the Work site, or on fences, offices or elsewhere adjacent to the Work site.

3-1.10 Project Schedule. Within 7 days of issuance of the Notice to Proceed, the Contractor must submit a schedule showing each task of Work, the sequence of each task, the number of days required to complete each task, and the critical path controlling the completion of the entire Work. The schedule must allow for the completion of the entire Work within the Time for Completion.

- a. District Review of Schedule. The District may review the Contractor's submitted schedule and may note any exceptions. The Contractor must correct any exceptions noted by the District within five (5) working days of being notified of the exceptions.
- b. Update of Schedule. After submission of a schedule to which the District has taken no exceptions, the Contractor must submit an updated schedule on a biweekly basis or as otherwise specified by the District until completion of the Work. The updated schedule must show the progress of Work as of the date specified in the updated schedule.
- c. Float. The schedule shall show early and late completion dates for each task. The number of days between these dates will be designated as "float". The Float will be designated to the Project and will be available to both the District and the Contractor as needed.
- d. Failure to Submit Schedule. If the Contractor fails to submit schedules within the time periods specified in this Section, or submit a schedule to which the District has taken uncorrected exceptions, the District may withhold payments to the Contractor until such schedules are submitted and/or corrected in accordance with the Contract Documents.
- e. Responsibility for Schedule. The Contractor will be solely and exclusively responsible for creating the schedule and properly updating it. The District may note exceptions to any schedule submitted by the Contractor. However, if the Contractor will be solely responsible for determining the proper method for addressing such exceptions and the District's review of the schedule will not place scheduling obligation on the District.

3-1.11 Construction Staking. Where the Contract Documents require, the Contractor shall employ a licensed Land Surveyor to perform construction staking. Stakes and marks will be set by the Surveyor as the Engineer determines to be necessary to establish the lines and grades required for the completion of the Work.

- a. The Contractor will be responsible for coordinating performance of the Work with the Surveyor and for all costs associated with construction staking and layout.
- b. Contractor shall provide "cutsheets" for the Engineer to review and use in checking grades. Finished grades shall be within 0.01 feet in elevation and 0.03 feet horizontal layout.
- c. Full compensation for Construction Staking shall be considered as included in the prices paid for the various items of Work involved, and no additional allowance will be made therefore.

3-1.12 Detours.

- a. The Contractor shall construct and remove detours and detour bridges for the use of public traffic as provided in the Special Provisions, or as shown on the Project plans or as directed by the Engineer. Payment for this Work will be made as set forth in the Special Provisions or at the contract prices for the items of Work involved
- b. The cost of repairing damage to detours caused by public traffic will be paid for as provided in this Section 3.
- c. When public traffic is routed through the Work, provision for a passageway through construction operations will not be considered as detour construction or detour maintenance, and this Work shall conform to and be paid for as provided in Section 6-1.16, "Public Convenience" unless otherwise specified in the Special Provisions.
- d. Detours used exclusively by the Contractor for hauling materials and equipment shall be constructed and maintained by the Contractor at the Contractor's expense.
- e. The failure or refusal of the Contractor to construct and maintain detours at the proper time shall be sufficient cause for suspending the Work until the detours are in satisfactory condition for use by public traffic.
- f. Where the Contractor's hauling is causing such damage to the detour that its maintenance in a condition satisfactory for public traffic is made difficult and unusually expensive, the Engineer shall have authority to regulate the Contractor's hauling over the detour.

3-1.13 District Directed Change Orders. The District may at any time during the progress of the Work direct any amendments to the Work or any of the Contract Documents, including, but not limited to the Technical Specifications, or Project Plans. Such amendments will in no way void the agreement, but will be applied to amend the Contract Price, if such amendments affect the Contract Price, the Project schedule, if such amendments affect the Project schedule, or any other provision of the Contract Documents based on a fair and reasonable valuation of the amendment in accordance with this Section 3.

3-1.14 Writing Requirement. Change orders and other amendments to the Technical Specifications, the Project Plans, or other Contract Documents may be made only by a writing executed by authorized representatives of the District and the Contractor.

3-1.15 Contractor Proposed Change Orders. Unless the Engineer otherwise authorizes or the District and the Contractor otherwise agree, change order proposals submitted by the Contractor must be submitted to the Engineer no later than the time of the proposed change. The Project Manager shall review the proposed change order and respond by acknowledging the contract change, supplying information and not acknowledging a change order, or recommending other action. If the Project Manager acknowledges the contract change, the Contractor shall submit a change order to the Project Manager as set forth in this Section. Each change order submitted by the Contractor shall be accompanied by the following certification executed by an officer of Contractor:

I, _____, being the _____ of _____ (Contractor), declare under penalty of perjury under the laws of the State of California, and do personally certify and attest that: I have thoroughly reviewed the attached request for change order and know its contents, and said request for change order is made in good faith; that it is supported by truthful and accurate data; that the amount requested and the additional time requested accurately reflects the allowable expenses that would be incurred, and the time necessary, to perform the change order; and further, that I am familiar with California Penal Code section 72 and California Government Code section 12650, et seq., pertaining to false claims, and further know and understand that submission or certification of a false claim may lead to fines, imprisonment, or other severe legal consequences.

3-1.16 All Change Orders. All proposed change orders must be submitted on completed Change Order forms provided in the Contract Documents. All such proposed change orders must itemize all cost impacts of the proposed change order and include a total price for that change order and the amended Contract Price that would become effective upon execution of the change order. All proposed change orders must specify any change in the Project schedule, or in any project milestone including, but not limited to, the Time for Completion, under the change order. It is understood that change orders that do not specify a change in any milestone, including, but not limited to, the Time for Completion, must be accomplished by the Time for Completion then in effect.

3-1.17 Change Order Pricing. Change order pricing for all change orders, whether, additive, deductive, or both, will be governed by the following:

- a. Prices specified in the Contract Documents will apply to cost impacts involving items for which the Contract Documents specify prices.
- b. Cost impacts involving items for which the Contract Documents do not specify prices may be paid on a lump sum basis as approved by the District.
- c. For cost impacts involving items for which the Contract Documents do not specify prices, and for which no lump sum amount has been approved by the

District, charges or credits for the Work will be paid on a time and materials basis in accordance with the following and subject to Caltrans Standard Specifications, provision 9-1.03, concerning allowable direct charges. The time and materials payment will be the sum of and limited to the direct and indirect costs for labor, materials, equipment and overhead calculated as follows:

1. Labor: The Contractor will be paid the cost of labor for the workers (including foremen when authorized by the Engineer), used in the actual and direct performance of the Work. The cost of labor utilized in performing the Work, whether the employer is the Contractor, a subcontractor or other entity engaged in the performance of the Work, will be the sum of the following:
 - Actual Wages: The actual wages paid will include any employer fringe benefit payments to or on behalf of the workers for health and welfare, pension, vacation and similar purposes. The actual wages and fringe benefits paid must be at the rates shown on the certified payroll documents submitted by the Contractor.
 - Labor Surcharge: The labor surcharge will be as set forth in the latest edition of the California Department of Transportation publication entitled "Labor Surcharge and Equipment Rental Rates". The labor surcharge will constitute full compensation for all payments imposed by State or Federal laws and for all other payments made to, or on behalf of, workers engaged in the performance of the Work, excluding the Actual Wages as defined above.
 - Fixed Markup: A fixed markup of 15% of the sum of the actual wages paid and the labor surcharge applicable to such actual wages, together with the actual wage and labor surcharge costs described in this provision will constitute full and complete compensation for all overhead, profit, incidentals, and any and all other direct or indirect expenses associated with furnishing all labor for the Work.
2. Materials: Materials costs will be the direct costs for materials actually exhausted, consumed or entering permanently into the Work, plus a fixed markup of 15% of such direct materials costs, which, together with the direct cost of materials as described in this provision will constitute full and complete compensation for all overhead, profit, incidentals, and any and all other direct or indirect expenses associated with furnishing all materials for the Work.
3. Equipment: All equipment used will be paid in accordance with the rates in subsection 9-1.04D (3) entitled "Equipment Rental" of the Standard

Specifications, plus a fixed markup of 10% of such equipment rates, which, together with the equipment rates as described in this provision will constitute full and complete compensation for all overhead, profit, incidentals, and any and all other direct or indirect expenses associated with furnishing all equipment for the Work.

4. Unless approved in writing in accordance with provision 3-1.14 of this Contract in advance of performance of the Work, any and all other cost impacts (including, but not limited to profit, bond premiums or fees, insurance premiums or fees, superintendent labor, clerical expenses, home office expenses, Work site office expenses, utility costs, permit costs, and licensing costs) involving items for which the Contract Documents do not specify prices, and for which no lump sum amount has been approved by the District, will constitute incidentals, full compensation for which will be deemed included in the markups for labor, material, and equipment specified above, and no additional compensation for such cost impacts will be allowed.

3-1.18 Liability Under Unapproved Change Orders. The Contractor will be solely responsible for any and all losses, costs, or liabilities of any kind incurred by the Contractor, any subcontractor engaged in the performance of the Work, any party supplying material or equipment for the Work or any third party that are incurred pursuant to Contractor-proposed change orders prior to issuance of an approved change order executed in accordance with this Section 3. The Contractor will have all of the obligations and the District will have all of the rights and remedies that are specified in Section 9 concerning any work or resulting losses, costs, or liabilities pursuant to a Contractor proposed change order before issuance of an approved change order executed in accordance with this Section 3.

3-1.19 Changes Subject to Contract Documents. Any changes in the Work and/or the Contract Documents pursuant to change orders and any other amendments issued in accordance with the Contract Documents, including this Section 3, will in all respects be subject to all provisions of the Contract Documents, including, but not limited to, the Technical Specifications and the Project Plans, except as modified by such change orders or amendments.

3-1.20 Change Order Disputes.

- a. Disputed District Directed Change Orders. If the Contractor disputes a District directed change order following a reasonable effort by the and the Contractor to resolve the dispute including, at a minimum, a meeting between appropriate representatives of the Contractor and the District, the Contractor must commence performing the Work consistent with the disputed change order within five (5) working days of the last meeting between representatives of the Contractor and the District to resolve the dispute, or within the time specified in the disputed District directed change order, whichever is later. In performing Work consistent with a disputed District-directed change order pursuant to this

provision the Contractor will have all of the Contractor's rights concerning claims pursuant to the Contract Documents and applicable law.

- b. Disputed Contractor Proposed Change Orders. If the District disputes a Contractor proposed change order, the District and the Contractor will use reasonable efforts to resolve the dispute including, at a minimum, holding a meeting between appropriate representatives of the Contractor and the District. Regardless of and throughout any such efforts to resolve the dispute the Contractor must continue performing the Work irrespective of and unmodified by the disputed change order. In continuing to perform the Work, the Contractor will retain all of the Contractor's rights under contract or law pertaining to resolution of disputes and protests between contracting parties. Disputes between the District and the Contractor concerning any Contractor-proposed change order or other amendment do not excuse the Contractor's obligation to perform the Work in accordance with the Contract Documents excluding such Contractor-proposed change order or other amendment by the Time for Completion or waive any other Project milestone or other requirement of the Contract Documents.

**SECTION 4
TRENCHING AND UTILITIES
AND
PROJECT FACILITIES**

4-1.01 The Construction Safety Orders of the Division of Occupational Safety and Health shall apply to all excavations.

- a. Detailed plans of protective systems for which the Construction Safety Orders require design by a registered professional engineer shall be prepared and signed by an engineer who is registered as a Civil Engineer in the State of California, and shall include the soil classification, soil properties, soil design calculations that demonstrate adequate stability of the protective system, and any other design calculations used in the preparation of the plan.
- b. No plan shall allow the use of a protective system less effective than that required by the Construction Safety Orders.
- c. If the detailed plan includes designs of protective systems developed only from the allowable configurations and slopes, or Appendices, contained in the Construction Safety Orders, the plan shall be submitted at least 5 days before the Contractor intends to begin excavation. If the detailed plan includes designs of protective systems developed from tabulated data, or designs for which design by a registered professional engineer is required, the plan shall be submitted at least 3 weeks before the Contractor intends to begin excavation.

4-1.02 Excavation More Than Four Feet Deep. In accordance with California Public Contract Code Section 7104, if the Work involves excavation more than four feet deep the Contractor must promptly notify the District in writing before disturbing: any material that the Contractor believes may be hazardous waste, as defined in Section 25117 of the Health and Safety Code, that is required to be removed to a Class I, Class II or Class III disposal site in accordance with provisions of existing law; any subsurface or latent physical conditions at the Work site differing from those indicated; or any unknown physical conditions at the Work site of any unusual nature, different materially from those ordinarily encountered and generally recognized as inherent in work of the character provided for in the Contract Documents. The District will promptly investigate any such conditions for which notice is given. If the District finds that the conditions do materially differ, or involve hazardous waste, and would cause a decrease or increase in the cost or time of performance of the Work, the District will issue a change order pursuant to Section 3 of these General Provisions. If a dispute arises between the District and the Contractor concerning whether the conditions materially differ, or involve hazardous waste, or cause a decrease of increase in the cost or time of performance, the Contractor will not be excused from any completion date provided in the Contract Documents, but shall proceed with all Work to be performed. The

Contractor will retain all rights under contract or law pertaining to resolution of disputes and protests between contracting parties.

4-1.03 Excavation of Five Feet or More. In accordance with California Labor Code Section 6705, contractors performing contracts exceeding \$25,000 in cost and involving excavation five or more feet deep must submit for the District's acceptance, prior to excavation, a detailed plan showing the design of shoring, bracing, sloping, or other provisions to be made for worker protection from the hazard of caving ground during excavation. The detailed plan shall include any tabulated data and any design calculations used in the preparation of the plan. Excavation shall not begin until the detail plan has been reviewed and approved. If the plan varies from the shoring system standards, it must be prepared by a registered civil or structural engineer.

4.1.04 Utility Relocation Costs.

- a. In accordance with California Government Code Section 4215, the District assumes the responsibility for the timely removal, relocation or protection of existing main or trunkline utility facilities located on the Work site if such utilities are not identified by the District in the Technical Specifications and/or Project Plans. The District will compensate the Contractor for the costs of locating, repairing damage not due to the Contractor's failure to exercise reasonable care, and removing or relocating existing main or trunkline utility facilities located at the Work site and not identified with reasonable accuracy in the Technical Specifications and/or Project Plans. The District will also compensate the Contractor for the cost of equipment on the Project necessarily idled during such work. The Contractor will not be assessed liquidated damages for Work completion delays caused by the District's failure to provide for removal or relocation of such main or trunkline utility facilities.
- b. Nothing in this provision or the Contract Documents will be deemed to require the District to indicate the presence of existing service laterals or appurtenances whenever the presence of such utilities on the Work site can be inferred from the presence of other visible facilities, such as buildings, meter and junction boxes, on or adjacent to the Work site; provided, however, that nothing in this provision or the Contract Documents shall relieve the District from identifying main or trunklines in the Technical Specifications and/or Project Plans.
- c. Nothing in this provision or the Contract Documents will preclude the District from pursuing any appropriate remedy against the utility for delays which are the responsibility of the utility.
- d. Nothing in this provision or the Contract Documents will be construed to relieve the utility from any obligation as required either by law or by contract to pay the cost of removal or relocation of existing utility facilities.

- e. If the Contractor while performing the Work discovers utility facilities not identified by the District in the Technical Specifications and/or Project Plans, the Contractor must immediately notify the District and utility in writing.
- f. Either the District or the utility, whichever owns existing main or trunkline utility facilities located on the Work site, shall have sole discretion to effect repairs or relocation work or to permit the Contractor to perform such repairs or relocation work at a reasonable price.

4-1.05 Utility and Non-Highway Facilities

- a. The Contractor shall protect from damage utility and other non-highway facilities that are to remain in place, be installed, relocated or otherwise rearranged.
- b. It is anticipated that some or all of the utility and other non-highway facilities, both above ground and below ground, that are required to be rearranged (as used herein, rearrangement includes installation, relocation, alteration or removal) as a part of the highway improvements comprising part of the Work will be rearranged in advance of construction operations. Where it is not anticipated that the rearrangement will be performed prior to construction, or where the rearrangement must be coordinated with the Contractor's construction operations, the existing facilities that are to be rearranged will be indicated on the Project Plans or in the Special Provisions. Where a rearrangement is indicated on the Project Plans or in the Special Provisions, the Contractor will have no liability for the costs of performing the work involved in the rearrangement.
- c. The right is reserved to the District and the owners of facilities, or their authorized agents, to enter upon the highway right of way for the purpose of making those changes that are necessary for the rearrangement of their facilities or for making necessary connections or repairs to their properties. The Contractor shall cooperate with forces engaged in this Work and shall conduct operations in such a manner as to avoid any unnecessary delay or hindrance to the Work being performed by the other forces. Wherever necessary, the work of the Contractor shall be coordinated with the rearrangement of utility or other non-highway facilities, and the Contractor shall make arrangements with the owner of those facilities for the coordination of the Work.
- d. Attention is directed to the possible existence of underground main or trunk line facilities not indicated on the Project Plans or in the Special Provisions and to the possibility that underground main or trunk lines may be in a location different from that which is indicated on the Project Plans or in the Special Provisions. The Contractor shall ascertain the exact location of underground main or trunk lines whose presence is indicated on the Project Plans or in the

Special Provisions, the location of their service laterals or other appurtenances, and of existing service lateral or appurtenances of any other underground facilities which can be inferred from the presence of visible facilities such as buildings, meters and junction boxes prior to doing Work that may damage any of the facilities or interfere with their service.

- e. If the Contractor cannot locate an underground facility whose presence is indicated on the Project Plans or in the Special Provisions, the Contractor shall so notify the Engineer in writing. If the facility for which the notice is given is in a substantially different location from that indicated on the Project Plans or in the Special Provisions, the additional cost of locating the facility will be paid for as provided in Section 3.
- f. If the Contractor discovers underground main or trunk lines not indicated on the Project Plans or in the Special Provisions, the Contractor shall immediately give the Engineer and the Utility Company written notification of the existence of those facilities. The main or trunk lines shall be located and protected from damage as directed by the Engineer, and the cost of that work will be paid for as extra work as provided in Section 3. The Contractor shall, if directed by the Engineer, repair any damage which may occur to the main or trunk lines. The cost of that repair work, not due to the failure of the Contractor to exercise reasonable care, will be paid for as provided in Section 3. Damage due to the Contractor's failure to exercise reasonable care shall be repaired at the Contractor's cost and expense.
- g. Where it is determined by the Engineer that the rearrangement of an underground facility is essential in order to accommodate the highway improvement and the Project Plans and Technical Specifications do not provide that the facility is to be rearranged, the Engineer will provide for the rearrangement of the facility by other forces or the rearrangement shall be performed by the Contractor and will be paid for as provided in Section 3.
- h. When ordered by the Engineer in writing, the Contractor shall rearrange any utility or other non-highway facility necessary to be rearranged as a part of highway improvements comprising part of the Work, and that Work will be paid for as provided in Section 3.
- i. Should the Contractor desire to have any rearrangement made in any utility facility, or other improvement, for the Contractor's convenience in order to facilitate the Contractor's construction operations, which rearrangement is in addition to, or different from, the rearrangements indicated on the Project Plans or in the Special Provisions, the Contractor shall make whatever arrangements are necessary with the owners of the utility or other non-highway facility for the rearrangement and bear all expenses in connection therewith.

- j. The Contractor shall immediately notify the Engineer of any delays to the Contractor's operations as a direct result of underground main or trunk line facilities which were not indicated on the Project Plans or in the Special Provisions or were located in a position substantially different from that indicated on the Project Plans or in the Special Provisions, or as a direct result of utility or other non-highway facilities not being rearranged as herein provided (other than delays in connection with rearrangement made to facilitate the Contractor's construction operations or delays due to a strike or labor dispute). Compensation for the delay will be determined in conformance with the provisions in Section 3.

4-1.06 Work Site Offices. Any Work site office facilities used by the Contractor and/or its privities must conform to all applicable codes, ordinances and regulations. The cost of such Work site office facilities shall be paid from and included in the Contract Price.

4-1.07 District Rights of Access and Ownership. The District and its authorized representatives will at all reasonable times while such office facilities are located at the Work site (including, at a minimum, all times during which the Work is performed), have access to any such Work site office facilities used by the Contractor and/or its privities. With respect to the right of access of the District and its authorized representatives, neither the Contractor nor its privities shall have a reasonable expectation of privacy pursuant to the Fourth Amendment to the Unites States Constitution or other applicable law concerning such Work site office facilities used by the Contractor and/or its privities. Without exception, any and all Project related materials located at such Work site facilities will be deemed at all times to be District property subject to inspection and copying by the District and its authorized representatives at all reasonable times while such facilities are located at the Work site (including, at a minimum, all times during which the Work is performed). Any interference by the Contractor or its privities with the District's rights of access and/or ownership pursuant to this Section 4 will constitute a material breach of the Agreement subject to any and all remedies available pursuant to the Contract Documents and at law and equity.

SECTION 5

PROSECUTION AND PROGRESS OF THE WORK

5-1.01 Beginning of Work.

- a. The Contractor shall begin Work within 10 calendar days after receiving notice to proceed from the District, and shall diligently prosecute the same to completion within the Time for completion specified in the Agreement.
- b. Should the Contractor begin Work in advance of receiving notice that the Agreement has been approved as above provided, any Work performed by the Contractor in advance of the date of approval shall be considered as having been done by the Contractor at the Contractor's own risk and as a volunteer unless the Agreement is approved.
- c. The delivery to the District for execution and approval of the Agreement properly executed on behalf of the Contractor and surety and provision of all other required documents in accordance with the Agreement shall constitute the Contractor's authority to enter upon the Work site and to begin operations, subject to the Contractor's assumption of the risk of the disapproval of the Agreement, as above provided, and subject also to the following:
 1. The Contractor shall, on commencing operations, take all precautions required for public safety and shall observe all the provisions in the Contract Documents.
 2. In the event of disapproval, the Contractor shall at the Contractor's expense do that work that is necessary to leave the site in a neat condition to the satisfaction of the Engineer. If the Work done affects any existing road or highway, the Contractor shall at the Contractor's expense restore it to its former condition, or the equivalent thereof, to the satisfaction of the Engineer.
 3. All Work done according to the Agreement prior to its approval, will, when the Agreement is approved, be considered authorized Work and will be paid for as provided in the Agreement.
 4. The Contractor shall not be entitled to any additional compensation or an extension of time for any delay, hindrance or interference caused by or attributable to commencement of Work prior to the date on which the Agreement was approved by the District.

5-1.02 Liquidated Damages. Time is of the essence in the Agreement. The District and the Contractor agree that it will be difficult and/or impossible to determine the actual damage which the District will sustain in the event of the Contractor's failure

to fully perform the Work or to fully perform all of the Contractor's obligations that have accrued pursuant to the Agreement by the Time for Completion. Accordingly, the District and the Contractor agree in accordance with California Government Code Section 53069.85 that the Contractor will forfeit and pay to the District liquidated damages in the sum of **\$1,500 per day** for each and every calendar day completion of the Work and/or performance of all of the Contractor's obligations that have accrued pursuant to the Agreement is delayed beyond the Time for Completion. The District and the Contractor further agree in accordance with California Government Code Section 53069.85 that the liquidated damages sum specified in this provision is not manifestly unreasonable under the circumstances existing at the time the Agreement was made, and that the District may deduct liquidated damages sums in accordance with this provision from any payments due or that may become due the Contractor under the Agreement.

5-1.03 No Damage for Delay Beyond District and Contractor Control. The Contractor will not be held responsible for delays in performance of the Work caused by delay beyond the control of both District and Contractor, such as by strikes, lockouts, or labor disturbances that are not within the control of the Contractor to resolve, lack or failure of transportation, or acts of other government entities. This provision will not apply where the delay would not have occurred but for a previous Contractor caused delay in the prosecution of the Work. The District will not be liable to the Contractor, any subcontractor or other entity engaged in the performance of the Work, any supplier, or any other person or organization, or to any surety or employee or agent of any of them, for damages arising out of or resulting from (i) delays beyond the control of the District and the Contractor including but not limited to fires, floods, epidemics, abnormal weather conditions, earthquakes and acts of God or acts or neglect by utility owners or other contractors performing other work, or (ii) delays caused by the District, its officials, officers, employees, agents, or volunteers, or delays caused by the Engineer or the Designer or Engineer, which delays are reasonable under the circumstances involved and/or are within the contemplation of the District and the Contractor. An extension of the Time for Performance in an amount equal to the time loss due to such delay(s) will be the Contractor's sole and exclusive remedy for such delay(s).

5-1.04 No Damage for Contractor Caused Delay. Contractor shall not be entitled to additional compensation for extended field or home office overhead, field supervision, costs of capital, interest, escalation charges, acceleration costs or other impacts for any delays to the extent such delays are caused by the failure of the Contractor or any subcontractor or other entity engaged in performance of the Work to perform the Work in accordance with the Contract Documents. Contractor may be eligible for additional compensation in excess of the Contract Price for delays caused by the District and/or its privities.

5-1.05 No Damage for Other Delay. Contractor will not be entitled to damages for delay to the Work caused by the following, which the District and Contractor agree will be deemed for purposes of California Public Contract Code Section 7102 either not

caused by the District, and/or within the contemplation of the District and the Contractor, and/or reasonable under the circumstances:

- a. Exercise of the District's right to sequence the Work in a manner that would avoid disruption to the District and other contractors based on: the failure of the Contractor or any subcontractor or other entity engaged in the performance of the Work to perform the Work in accordance with the Contract Documents, enforcement by the District or any other governmental agency of competent jurisdiction of any government act or regulation, or enforcement by the District of any provisions of the Agreement.
- b. Requests for clarification or information concerning the Contract Documents or proposed change orders or modifications to the Contract Documents, including extensive and/or numerous such requests for clarification or information or proposed change orders or modifications, provided such clarifications or information or proposed change orders or modifications are processed by the District or its representatives in a reasonable time in accordance with the Contract Documents.

5-1.06 Delays Caused by the District and/or Its Privities. Either the District or the Contractor may propose a change in the Time for Completion for delays that are purported to be caused by the District and/or its privities and that are not reasonable under the circumstances involved and/or that are not within the contemplation of the District and the Contractor. Such proposed changes in the Time for Completion will constitute change order proposals subject to Section 3. In accordance with Section 3, the District and the Contractor may agree upon pricing for the cost impacts, if any, resulting from such delays. If such pricing is in anticipation of cost impacts that may, but have not yet occurred, the District will be obligated to pay the Contractor for such anticipated impacts in accordance with the Agreement and any applicable, approved change orders only to the extent the Contractor actually incurs the anticipated cost impacts. Notwithstanding anything to the contrary in Section 3, the District and the Contractor may agree to a daily rate or cap or lump sum that will apply to the cost impacts, if any, resulting from delay purportedly caused by the District and/or its privities subject to this provision. However, if such daily rate or cap or lump sum is in anticipation of cost impacts that have not yet occurred, the District will be obligated to pay such daily rate or cap or lump sum only to the extent the Contractor actually incurs such cost impacts.

5-1.07 Weather Delays. Extensions of the Time for Completion will not be allowed for weather conditions that are consistent with the historical rain days reflected in historical weather data of the National Oceanographic and Atmospheric Administration (NOAA) of the U.S. Department of Commerce for the record station that is nearest or most applicable to the Work site. Extensions of the Time for Completion for delays due to adverse weather will be allowed only if the number of rain days exceeds those that can be anticipated based on the NOAA data and the Contractor can verify to the District's reasonable satisfaction that such

adverse weather caused actual delay in the timely completion of the Work. No extensions of the Time for Completion will be granted for rain days that exceed those that can be anticipated based on the NOAA data and that merely result in delays that do not or would not, themselves, result in failure to complete the Work by the Time for Completion.

5-1.08 Delay Claims. Whenever the Contractor claims a delay for which the Time for Completion may be extended, the Contractor must request an extension of time within five (5) days of the start of the delay. The request must be in writing and describe in detail the cause for the delay, and, if possible, the foreseeable extent of the delay.

5-1.09 Contractor Coordination of the Work.

- a. The District reserves the right to do other work in connection with or in the vicinity of the Project by contract or otherwise, and Contractor shall at all times conduct the Work so as to impose no hardship on the District, others engaged in the Work or other contractors working at the Work site. The Contractor will adjust, correct and coordinate the Work with the work of others so that no delays result in the Work or other work at or near the Work site.
- b. If any part of the Work depends for proper execution or results upon the work of the District or any other contractor, the Contractor will, before proceeding with such Work, promptly report to the District any apparent discrepancies or defects in such other Work. Failure of the Contractor to promptly report any apparent discrepancy or defect will be deemed an acceptance of the District's or other contractor's Work as fit and proper.
- c. The Contractor will anticipate the relations of the various trades to the progress of the Work and will ensure that required anchorage or blocking is furnished and set at proper times. Anchorage and blocking necessary for each trade shall be part of the Work except where stated otherwise.
- d. The Contractor will provide proper facilities at all times for access of the District, the Engineer, Designer, and other authorized District representatives to conveniently examine and inspect the Work.
- e. Should construction be under way by other forces or by other contractors within or adjacent to the limits of the Work specified or should work of any other nature be under way by other forces within or adjacent to those limits, the Contractor shall cooperate with all the other contractors or other forces to the end that any delay or hindrance to their work will be avoided. The right is reserved to perform other or additional work at or near the site (including material sources) at any time, by the use of other forces.

- f. When 2 or more contractors are employed on related or adjacent work, or obtain materials from the same material source, each shall conduct their operations in such a manner as not to cause any unnecessary delay or hindrance to the other.
- g. Each contractor shall be responsible to the other for all damage to Work, to persons or property caused to the other by their operations, and for loss caused the other due to unnecessary delays or failure to finish the work within the time specified for completion.

5-1.10 Differing Site Conditions.

- a. During the progress of the Work, if subsurface or latent physical conditions are encountered at the site differing materially from those indicated in the Agreement or if unknown physical conditions of an unusual nature, differing materially from those ordinarily encountered and generally recognized as inherent in the Work, are encountered at the site, the Contractor shall promptly notify the District in writing of the specific differing conditions before they are disturbed and before the affected work is performed.
- b. Upon written notification, the Engineer will investigate the conditions, and if the Engineer determines that the conditions materially differ and cause an increase or decrease in the cost or time required for the performance of any Work, an adjustment, excluding loss of anticipated profits, will be made and the Agreement modified in writing accordingly. The Engineer will notify the Contractor of the Engineer's determination whether or not an adjustment of the contract is warranted.
- c. No Agreement adjustment that results in a benefit to the Contractor will be allowed unless the Contractor has provided the written notice required in this Section 5-1.10.
- d. Any Agreement adjustment warranted due to differing site conditions will be made in accordance with the provisions in Section 3, "Changes in Work," except as otherwise provided.

5-1.11 Relief From Maintenance And Responsibility.

- a. Upon the request of the Contractor, the District may relieve the Contractor of the duty of maintaining and protecting certain portions of the Work as described below, which have been completed in all respects in accordance with the requirements of the Agreement and to the satisfaction of the Engineer, and thereafter except with the Contractor's consent, the Contractor will not be required to do further Work thereon. In addition, such action by the District will relieve the Contractor of responsibility for injury or damage to those completed portions of the Work resulting from use by public traffic or from the

action of the elements or from any other cause but not from injury or damage resulting from the Contractor's own operations or from the Contractor's negligence.

- b. However, nothing in this Section 5-1.11 providing for relief from maintenance and responsibility will be construed as relieving the Contractor of full responsibility for making good any defective Work or materials found at any time before the formal written acceptance of the entire Agreement by the District.

SECTION 6

CONTRACTOR RESPONSIBILITIES

6-1.01 Eligibility. By executing the Agreement, the Contractor certifies that the Contractor is not ineligible to perform work on public works projects pursuant to California Labor Code Sections 1777.1 or 1777.7. In accordance with California Public Contract Code Section 6109(a), contractors who are ineligible to perform work on public works projects pursuant to California Labor Code Sections 1777.1 or 1777.7 may neither bid on, be awarded or perform the Work. To the full extent permitted by law the Contractor shall hold harmless and indemnify the District from and against any and all damages, costs, and liability arising from or as a consequence of any violation of Public Contract Code Section 6109.

6-1.02 Supervision of the Work. The Contractor will be solely responsible for the performance of the Work, including portions of the Work to be performed by subcontractors. The Contractor is charged with ensuring that all orders or instructions from the District, Engineer or Designer are disseminated to and followed by all subcontractors engaged in performance of the Work. The Contractor will supervise the Work using the Contractor's best skill and attention. At any time during the progress of the Work, the District, the Engineer, or the Designer may require the Contractor and/or subcontractors engaged in performance of the Work to attend a project meeting and the Contractor will attend, and ensure the attendance of any subcontractors whose attendance is required by the District and/or advisable in light of the matters to be addressed at the meeting.

6-1.03 Contractor's Superintendent. The Contractor will keep on the Work, throughout its progress, a competent superintendent and any necessary assistants, all satisfactory to the District. The Contractor shall designate in writing before starting Work the superintendent who shall have the authority to represent and act for the Contractor. The authorized representative shall be present at the site of the Work at all times While work is actually in progress. When Work is not in progress and during periods when Work is suspended, arrangements acceptable to the Engineer shall be made for any emergency Work that may be required. Whenever the Contractor or the Contractor's authorized representative is not present on any particular part of the Work where it may be desired to give direction, orders will be given by the Engineer, which shall be received and obeyed by the superintendent or foreman who may have charge of the particular Work in reference to which the orders are given. Any order given by the Engineer, not otherwise required by the specifications to be in writing, will on request of the Contractor, be given or confirmed by the Engineer in writing. The superintendent may not be changed without the consent of the District. The superintendent will represent the Contractor and all directions given by the District to the superintendent will bind the Contractor in accordance with the Agreement. Superintendent time included in Contractor's completed bid schedule and/or in approved change orders, if any, must be included in Contractor's approved overhead rate and may not be charged as a direct cost.

6-1.04 Competent Employees. The Contractor must at all times enforce strict discipline and good order among the Contractor's employees and may not employ on the Work any unfit person or anyone not skilled in the Work assigned, or anyone incompetent or unfit for the duties of that person. When the District determines that a Contractor employee does not satisfy the requirements of this provision, upon notice from the District, the Contractor must ensure that employee performs no further Work and is no longer present at the Work site. Any such Contractor employee may not again be employed on the Work without District approval. If any subcontractor or person employed by the Contractor shall appear to the Engineer to be incompetent or to act in a disorderly or improper manner, they shall be discharged immediately on the request of the Engineer, and that person shall not again be employed on the work.

6-1.05 Items Necessary for Proper Completion of the Work. Except as otherwise noted in the Contract Documents, the Contractor will provide and pay for all labor, materials, equipment, permits, fees, licenses, facilities and services necessary for the proper execution and timely completion of the Work in accordance with the Contract Documents.

6-1.06 Construction Reports. The Contractor must submit daily construction logs detailing the daily progress of the Work to the Engineer on a weekly basis.

6-1.07 Subcontracting.

- a. By executing the Agreement, the Contractor certifies that no subcontractor included on the list of proposed subcontractors submitted with the Contractor's bid is ineligible to perform work on public works projects pursuant to California Labor Code Sections 1777.1 or 1777.7. In accordance with California Public Contract Code Section 6109(a), subcontractors who are ineligible to perform work on public works projects pursuant to California Labor Code Sections 1777.1 or 1777.7 may neither bid on, be awarded or perform as a subcontractor on the Work. In accordance with California Public Contract Code Section 6109(b), any contract on a public works project entered into between a contractor and a debarred subcontractor is void as a matter of law. The Contractor will ensure that no debarred subcontractor receives any public money for performing the Work, and any public money that may have been paid to a debarred subcontractor for the Work is returned to the District. The Contractor will be responsible for payment of wages to workers of a debarred subcontractor who has been allowed to perform the Work.
- b. The Agreement and the performance of the Work are subject to the requirements of the Subletting and Subcontracting Fair Practices Act codified at California Public Contract Code Section 4100 and following. If the Contractor fails to specify a subcontractor or specifies more than one subcontractor for the same portion of the Work in excess of one-half of 1

percent of the Contractor's total bid, the Contractor agrees that the Contractor is fully qualified to perform that portion of the Work with the Contractor's own forces, and that the Contractor will perform that portion of the Work with the Contractor's own forces. If after award of the Agreement the Contractor subcontracts, except as provided for in California Public Contract Code Sections 4107 or 4109, any such portion of the Work, the Contractor will be subject to the penalties set forth in California Public Contract Code Sections 4110 and 4111, including cancellation of the Agreement, assessment of a penalty of up to 10 percent of the amount of the subcontract, and disciplinary action by the Contractors State License Board.

- c. No contractual relationship exists between the District and any subcontractor engaged in performance of the Work.
- d. Incorporation of Contract Documents. The Contractor must incorporate the Contract Documents in each contract with a subcontractor engaged in the performance of the Work. The Contractor will be solely responsible for any delay or additional costs incurred as a result of its failure to provide adequate or accurate project information to a subcontractor that results in improper submittals and/or work, or time or other impacts is the sole responsibility of the Contractor. The Contractor will have all of the obligations and the District will have all of the remedies that are specified in Section 9 concerning any subcontracted work. Subcontracts shall also contain certification by the subcontractor that the subcontractor is experienced in and qualified to do, and knowledgeable about, the subcontracted Work. Copies of subcontracts shall be available to the Engineer upon written request, and shall be provided to the Engineer at the time any litigation against the District concerning the project is filed.
- e. Coordination of Subcontract Work: The Contractor is responsible for scheduling the Work of subcontractors so as to avoid delay or injury to either Work or materials.
- f. The Contractor shall give personal attention to the fulfillment of the contract and shall keep the work under the Contractor's control.
- g. The Contractor shall perform, with the Contractor's own organization, contract work amounting to not less than 50 percent of the original total contract price, except that any designated "Specialty Items" may be performed by subcontract and the amount of any designated "Specialty Items" performed by subcontract may be deducted from the original total contract price before computing the amount of Work required to be performed by the Contractor with the Contractor's own organization. When items of work in the Engineer's Estimate are preceded by the letters (S) or (S-F), those items are designated as "Specialty Items." Where an entire item is subcontracted, the value of Work subcontracted will be based on the Agreement item bid price. When a portion of an item is

subcontracted, the value of Work subcontracted will be based on the estimated percentage of the Agreement item bid price, determined from information submitted by the Contractor, subject to approval by the Engineer.

- h. Before work is started on a subcontract, the Contractor shall file with the Engineer a written statement showing the work to be subcontracted, the names of the subcontractors and the description of each portion of the Work to be subcontracted.
- i. Pursuant to the provisions of Section 6109 of the Public Contract Code, the Contractor shall not perform Work on a public works project with a subcontractor who is ineligible to perform Work on the public works project pursuant to Section 1777.1 or 1777.7 of the Labor Code.
- j. When a portion of the Work which has been subcontracted by the Contractor is not being prosecuted in a manner satisfactory to the District, the subcontractor shall be removed immediately on the request of the District and shall not again be employed on the Work.
- k. The roadside production of materials produced by other than the Contractor's forces shall be considered as subcontracted. Roadside production of materials shall be construed to be production of aggregates of all kinds with portable, semiportable or temporary crushing or screening, proportioning and mixing plants established or reopened for the purpose of supplying aggregate or material for a particular project or projects. The erection, establishment or reopening of the plants and the operation thereof in the production of materials for use on the Work shall conform to the requirements relating to labor set forth in these General Provisions and in the Special Provisions.

6-1.08 Insurance.

Contractor shall procure and maintain for the duration of the contract insurance against claims for injuries to persons or damages to property which may arise from or in connection with the performance of the work hereunder by the Contractor, his agents, representatives, employees or subcontractors.

- a. All required insurance shall be provided in the form of “occurrence”-type policies underwritten by admitted insurers in the State of California with a rating of A:VII or better from the current year Best Rating Guide. All policies must be issued at the expense of the Contractor and must be maintained at the Contractor’s expense throughout the performance of the Work.
- b. The Contractor and any subcontractors engaged in performance of the Work must secure payment of workers compensation in accordance with California

Labor Code Section 3700 and other applicable law. The Contractor must verify that all Subcontractors comply with this requirement.

- c. Within ten working days following notice of award the Contractor must submit to the Agency along with executed copies of all other documents specified in the Contract Check List certificates of insurance and endorsements evidencing that the Contractor has in effect and will maintain throughout the performance of the Work the following kinds and amounts of insurance against claims for injuries to persons or damages to property which may arise from or in connection with the performance of the work hereunder by the Contractor, his agents, representatives, employees or subcontractors:

Minimum Scope of Insurance

Coverage shall be at least as broad as:

1. Insurance Services Office Commercial General Liability coverage (occurrence form CG 0001).
2. Insurance Services Office form number CA 0001 (Ed. 1/87) covering Automobile Liability, code 1 (any auto).
3. Workers' Compensation insurance as required by the State of California and Employer's Liability Insurance.
4. **Coverage shall not extend to any indemnity coverage for the active negligence of the additional insured in any case where an agreement to indemnify the additional insurance would be invalid under Subsection (b) of Section 2782 of the Civil Code.**

Minimum Limits of Insurance

Contractor shall maintain limits no less than:

1. General Liability: \$2,000,000 per occurrence for bodily injury, personal injury and property damage **including operations, products and completed operations**. If Commercial General Liability Insurance or other form with a general aggregate limit is used, either the general aggregate limit shall apply separately to this project/location or the general aggregate limit shall be twice the required occurrence limit.
2. Automobile Liability: \$2,000,000 per accident for bodily injury and property damage.
3. Employer's Liability: \$1,000,000 per accident for bodily injury or disease.

Deductibles and Self-Insured Retentions

Any deductibles or self-insured retentions must be declared to and approved by the District. At the option of the District, either: the insurer shall reduce or eliminate such deductibles or self-insured retentions as respects the District, its officers, officials, employees and volunteers; or the Contractor shall provide a financial guarantee satisfactory to the District guaranteeing payment of losses and related investigations, claim administration and defense expenses.

Other Insurance Provisions

The general liability and automobile liability policies are to contain, or be endorsed to contain, the following provisions:

1. The District, its officers, officials, employees, and volunteers are to be covered as additional insureds with respect to liability arising out of automobiles owned, leased, hired or borrowed by or on behalf of the contractor; and with respect to liability arising out of work or operations performed by or on behalf of the Contractor including materials, parts or equipment furnished in connection with such work or operations. General and auto liability coverage can be provided in the form of an endorsement to the Contractor's insurance, or as a separate owner's policy.
2. For any claims related to this project, the Contractor's insurance coverage shall be primary insurance as respects the District, its officers, officials, employees, and volunteers. Any insurance or self-insurance maintained by the District, its officers, officials, employees, or volunteers shall be excess of the Contractor's insurance and shall not contribute with it.
3. Each insurance policy required by this clause shall be endorsed to state that coverage shall not be canceled by either party, except after thirty (30) days' prior written notice by certified mail, return receipt requested, has been given to the District.
4. **Coverage shall not extend to any indemnity coverage for the active negligence of the additional insured in any case where an agreement to indemnify the additional insured would be invalid under Subsection (b) of Section 2782 of the Civil Code.**

Waiver of Subrogation

The worker's compensation policy is to be endorsed with a waiver of subrogation. The insurance company, in its endorsement, agrees to waive all rights against the District, its officers, officials, employees and volunteers for losses paid under the terms of this policy which arise from the work performed by the named insured for the District.

Verification of Coverage

Contractor shall furnish the District with original certificates and amendatory endorsements as approved by the District effecting coverage required by this clause. The endorsements should be on forms provided by the District or on other than the District's forms, provided those endorsements or policies conform to the requirements. All certificates and endorsements are to be received and approved by the District before work commences. The District reserves the right to require complete, certified copies of all required insurance policies, including endorsements affecting the coverage required by these specifications at any time.

Subcontractors

Contractor shall include all subcontractors as insureds under its policies or shall furnish separate certificates and endorsements for each subcontractor. All coverage's for subcontractors shall be subject to all of the requirements stated herein.

- d. For each insurance policy required under the Agreement (except for the required workers compensation insurance policy) the Contractor must provide endorsements that add the District, its officers, officials, employees and volunteers as an additional insured. Such endorsements must: provide that the insurance required to be furnished by the Contractor will be primary as regards the Agency, and that the Agency's insurance will be excess of and not contribute to the insurance required to be furnished by the Contractor; that the Agency will receive 30 day written notice of any reduction or cancellation of such insurance required to be furnished by the Contractor; and include a severability of interest clause acceptable to the Agency. Said endorsement shall be at least as broad as Insurance Services Office form number CG2010 (Ed. 11/85).

6-1.09 Indemnities.

- a. The Contractor will take all responsibility for the Work, and will bear all losses and damages directly or indirectly resulting to the Contractor, any subcontractors engaged in performance of the Work, the District, its officials, officers, employees, agents, volunteers and consultants, and to third parties on account of the performance or character of the Work, unforeseen difficulties, accidents, or occurrences of other causes predicated on active or passive negligence of the Contractor or of any subcontractor engaged in performance of the Work. To the fullest extent permitted by law the Contractor will indemnify, defend and hold harmless the District, its officials, officers, employees, agents, volunteers and consultants from and against any or all loss, liability, expense, claims, costs (including costs of defense), suits, and damages of every kind, nature and description (including, but not limited to, penalties resulting from exposure to hazards in violation of the California Labor Code) directly or indirectly arising from the performance of the Work ("Claims").
- b. The Contractor will indemnify, defend and hold harmless the District, the District's officials, officers, employees, volunteers, agents and the Engineer and Designer for all liability on account of any patent rights, copyrights, trade names or other intellectual property rights that may apply to the Contractor's performance of the Work. The Contractor will pay all royalties or other charges as a result of intellectual property rights that may apply to methods, types of construction, processes, materials, or equipment used in the performance of the Work, and will furnish written assurance satisfactory to the District that any such charges have been paid.

- c. The Contractor assumes all liability for any accident or accidents resulting to any person or property as a result of inadequate protective devices for the prevention of accidents in connection with the performance of the Work. The Contractor will indemnify, defend, and hold harmless the District and its officials, officers, employees, agents, volunteers and consultants from such liability.
- d. Approval of the Contractor's certificates of insurance and/or endorsements does not relieve the Contractor of liability under Sections 6-1.08 or 6-1.09. The Contractor will defend, with legal counsel reasonably acceptable to the District, any action or actions filed in connection with any Claims and will pay all related costs and expenses, including attorney's fees incurred. The Contractor will promptly pay any judgment rendered against the District, its officials, officers, employees, agents, volunteers or consultants for any Claims. In the event the District, its officials, officers, employees, agents, volunteers or consultants is made a party to any action or proceeding filed or prosecuted against Contractor for any Claims, Contractor agrees to pay the District, its officials, officers, employees, agents, volunteers and consultants any and all costs and expenses incurred in such action or proceeding, including but not limited to, reasonable attorneys' fees.
- e. In accordance with California Civil Code Section 2782(a), nothing in the Agreement will be construed to indemnify the District for its sole negligence, willful misconduct, or for defects in design furnished by District. In accordance with California Civil Code Section 2782(b), nothing in the Agreement will be construed to impose on the Contractor or to relieve the District from liability for the District's active negligence. By execution of the Contract Documents the Contractor acknowledges and agrees that the Contractor has read and understands the insurance and indemnity requirements of the Contract Documents, which are material elements of consideration.

6-1.10 Licenses/Permits. The Contractor must, without additional expense to the District, obtain all licenses, permits and other approvals required for the performance of the Work.

6-1.11 California Labor Code Requirements.

- a. In accordance with California Labor Code Section 1810, eight (8) hours of labor in performance of the Work shall constitute a legal day's work under the Agreement.
- b. In accordance with California Labor Code Section 1811, the time of service of any worker employed in performance of the Work is limited to eight hours during any one calendar day, and forty hours during any one calendar week, except in accordance with California Labor Code Section 1815, which provides that work in excess of eight hours during any one calendar day and forty hours

during any one calendar week is permitted upon compensation for all hours worked in excess of eight hours during any one calendar day and forty hours during any one calendar week at not less than one-and-one-half times the basic rate of pay.

- c. The Contractor and its subcontractors will forfeit as a penalty to the District \$25 for each worker employed in the performance of the Work for each calendar day during which the worker is required or permitted to work more than eight (8) hours in any one calendar day, or more than forty (40) hours in any one calendar week, in violation of the provisions of California Labor Code Section 1810 et seq.
- d. In accordance with California Labor Code Section 1773.2, the District has determined the general prevailing wages in the locality in which the Work is to be performed for each craft or type of work needed to be as published by the State of California Department of Industrial Relations, Division of Labor Statistics and Research, a copy of which is on file in the office of Coastland Civil Engineering and shall be made available on request. The Contractor and subcontractors engaged in the performance of the Work shall pay no less than these rates to all persons engaged in performance of the Work.
- e. In accordance with California Labor Code Section 1775, the Contractor and any subcontractors engaged in performance of the Work must comply with Labor Code Section 1775, which establishes a penalty of up to \$200 per day for each worker engaged in the performance of the Work that the Contractor or any subcontractor pays less than the specified prevailing wage. The amount of such penalty shall be determined by the Labor Commissioner. The Contractor or subcontractor shall pay the difference between the prevailing wage rates and the amount paid to each worker for each calendar day or portion thereof for which each worker was paid less than the prevailing wage rate. If a subcontractor worker engaged in performance of the Work is not paid the general prevailing per diem wages by the subcontractor, the Contractor is not liable for any penalties therefore unless the Contractor had knowledge of that failure or unless the Contractor fails to comply with all of the following requirements:
 - 1. The contract executed between the Contractor and the subcontractor for the performance of part of the Work must include a copy of the provisions of California Labor Code Sections 1771, 1775, 1776, 1777.5, 1813, and 1815.
 - 2. The Contractor must monitor payment of the specified general prevailing rate of per diem wages by the subcontractor by periodic review of the subcontractor's certified payroll records.

3. Upon becoming aware of a subcontractor's failure to pay the specified prevailing rate of wages, the Contractor must diligently take corrective action to halt or rectify the failure, including, but not limited to, retaining sufficient funds due the subcontractor for performance of the Work.
 4. Prior to making final payment to the subcontractor, the Contractor must obtain an affidavit signed under penalty of perjury from the subcontractor that the subcontractor has paid the specified general prevailing rate of per diem wages employees engaged in the performance of the Work and any amounts due pursuant to California Labor Code Section 1813.
 5. In accordance with California Labor Code Section 1771.4, the project is subject to compliance monitoring and enforcement by the Department of Industrial Relations. In accordance with California Labor Code Section 1776, the Contractor and each subcontractor engaged in performance of the Work, must keep accurate payroll records showing the name, address, social security number, work classification, straight time and overtime hours worked each day and week, and the actual per diem wages paid to each journeyman, apprentice, worker, or other employee employed in performance of the Work. Each payroll record must contain or be verified by a written declaration that it is made under penalty of perjury, stating that the information contained in the payroll record is true and correct and that the employer has complied with the requirements of Sections 1771, 1811, and 1815 for any work performed by the employer's employees on the public works project. The payroll records required pursuant to California Labor Code Section 1776 must be certified and must be available for inspection by the District and its authorized representatives, the Division of Labor Standards Enforcement, and the Division of Apprenticeship Standards of the Department of Industrial Relations and must otherwise be available for inspection in accordance with California Labor Code Section 1776. In addition, in accordance with California Labor Code Section 1771.4, the Contractor and its subcontractor(s) shall furnish the records specified in California Labor Code Section 1776 directly to the Labor Commissioner at least monthly (or more frequently if specified in the Contract Documents); and in a format prescribed by the Labor Commissioner.
 6. In accordance with California Labor Code Section 1771.4, the Contractor shall post job site notices, as prescribed by regulation.
- f. By executing the Agreement, in accordance with California Labor Code Section 1771(a), the Contractor represents that it and all of its Subcontractors are currently registered and qualified to perform public work pursuant to Labor Code Section 1725.5. The Contractor covenants that any additional or substitute Subcontractors will be similarly registered and qualified.

- g. In accordance with California Labor Code Section 1777.5, the Contractor, on behalf of the Contractor and any subcontractors engaged in performance of the Work, will be responsible for ensuring compliance with California Labor Code Section 1777.5 governing employment and payment of apprentices on public works contracts.
- h. In case it becomes necessary for the Contractor or any subcontractor engaged in performance of the Work to employ on the Work any person in a trade or occupation (except executive, supervisory, administrative, clerical, or other non manual workers as such) for which no minimum wage rate has been determined by the Director of the Department of Industrial Relations, the Contractor must pay the minimum rate of wages specified therein for the classification which most nearly corresponds to Work to be performed by that person. The minimum rate thus furnished will be applicable as a minimum for such trade or occupation from the time of the initial employment of the person affected and during the continuance of such employment.

6-1.12 Laws and Ordinances. The Contractor and all subcontractors engaged in the performance of the Work must conform to the following specific rules and regulations as well as all other laws, ordinances, rules and regulations that apply to the Work. Nothing in the Technical Specifications or Project Plans is to be construed to permit Work not conforming to these codes:

- National Electrical Safety Code, U. S. Department of Commerce
- National Board of Fire Underwriters' Regulations
- California Building Standards Code as adopted by the District
- Manual of Accident Prevention in Construction, latest edition, published by A.G.C. of America
- Industrial Accident Commission's Safety Orders, State of California
- Regulations of the State Fire Marshall (Title 19, California Code of Regulation) and Applicable Local Fire Safety Codes
- Labor Code of the State of California - Division 2, Part 7, Public Works and Public Agencies.

6-1.13 Guaranty. The Contractor guarantees all of the Work for one year from the date the District accepts the Work. Upon receiving written notice of a need for repairs which are directly attributable to defective materials or workmanship the Contractor must make good any defects arising or discovered in any part of the Work by diligently commencing the necessary repairs within seven (7) days from the date of notice from the District. If the Contractor fails to make good any defects in the Work in accordance with this provision, in addition to any other available remedy under the contract or at law or equity, the District may make good or have made good such defects in the Work and deduct the cost from amounts that may be due or become due the Contractor, and/or call on the Contractor's maintenance bond for the cost of making good such defects and for the District's reasonable legal costs, if any, of recovering against the bond. The Contractor will remain

responsible for repairing any Work found to be defective regardless of when such defect is discovered by the District.

6-1.14 Safety.

- a. In accordance with generally accepted construction practices and applicable law, the Contractor will be solely and completely responsible for conditions of the Work site, including safety of all persons and property during performance of the Work. This requirement will apply continuously and not be limited to normal working hours. For purposes of California Labor Code Section 6400 and related provisions of law, the Contractor and the Contractor's privities and any other entities engaged in the performance of the Work will be "employers" responsible for furnishing employment and a place of employment that is safe and healthful for the employees, if any, of such entities engaged in the performance of the Work. Neither the District nor its officials, officers, employees, agents, volunteers or consultants will be "employers" pursuant to California Labor Code Section 6400 and related provisions of law with respect to the Contractor, the Contractor's privities or other entities engaged in the performance of the Work.
- b. Review and inspection by the District, the Engineer, the Designer or Engineer, and/or other representatives of the District of the Contractor's performance of the Work will not constitute review of the adequacy of the Contractor's safety measures in, on, or near the Work site. Such reviews and inspections do not relieve the Contractor of any of the Contractor's obligations under the Contract Documents and applicable law to ensure that the Work site is maintained and the Work is performed in a safe manner.
- c. The Contractor will be solely responsible for the implementation and maintenance of safety programs to ensure that the Work site is maintained and the Work is performed in a safe manner in accordance with the Contract Documents and applicable law.
- d. Within ten (10) working days following notice of award the Contractor must submit to the District a copy of the Contractor's Safety Plan.
- e. The Contractor must furnish and place proper guards and systems for the prevention of accidents, including, but not limited to, those systems required pursuant to Title 8, Section 1670 and following of the California Code of Regulations concerning safety belts and nets. The Contractor must provide and maintain any other necessary systems or devices required to secure safety of life or property at the Work site in accordance with accepted standards of the industry and applicable law. The Contractor must maintain during all night hours sufficient lights to prevent accident or damage to life or property.

6-1.15 Load Limitations.

- a. Unless expressly permitted in the Special Provisions, construction equipment or vehicles of any kind which, laden or unladen, exceed the maximum weight limitations set forth in Division 15 of the Vehicle Code, shall not be operated over completed or existing treated bases, surfacing, pavement or structures in any areas within the limits of the project.
- b. After application of the curing seal, no traffic or Contractor's equipment will be permitted on cement treated base or lean concrete base for a period of 72 hours. After 72 hours, traffic and equipment operated on the base shall be limited to that used in paving operations and placing additional layers of cement treated base. No traffic or Contractor's equipment will be permitted on treated permeable base except for that equipment required to place the permeable base and the subsequent layer of pavement. Trucks used to haul treated base, portland cement concrete, or asphalt concrete shall enter onto the base to dump at the nearest practical entry point ahead of spreading equipment. Empty haul trucks shall exit from the base at the nearest practical exit point. Entry and exit points shall not be more than 1,000 feet ahead of spreading equipment except in locations where specifications prohibit operation of trucks outside the area occupied by the base or where steep slopes or other conditions preclude safe operation of hauling equipment. In those locations, entry and exit points shall be established at the nearest point ahead of spreading equipment permitted by specifications and allowing safe operation of hauling equipment. Damage to curing seal or base shall be repaired promptly by the Contractor, at the Contractor's expense, as directed by the Engineer.
- c. Within the limits of the project and subject to the control of the Engineer, and provided that the Contractor, at the Contractor's expense, shall provide such protective measures as are deemed necessary by the Engineer and shall repair any damage caused by the operations, the Contractor will be permitted to:
 1. Make transverse crossings of those portions of an existing public road or street that are within the highway right of way, with construction equipment that exceeds the size or weight limitations set forth in Division 15 of the Vehicle Code.
 2. Make transverse crossings of treated bases, surfacing or pavement which are under construction or which have been completed, with construction equipment which exceeds the size or weight limitations set forth in Division 15 of the Vehicle Code.
 3. Cross bridge structures that are not open to public traffic and that are designed for HS20-44 Live Loading (culverts and pipes excluded), with construction equipment which exceeds the size or weight limitations set forth in Division 15 of the Vehicle Code, but not exceeding the load

limitations hereinafter specified, provided that the Contractor furnishes to the Engineer the dimensions and maximum axle loadings of equipment proposed for use on bridge structures:

- A. The maximum loading on bridge structures due to pneumatic-tired truck and trailer combinations shall not exceed (1) 28,000 pounds for single axles, (2) 48,000 pounds for tandem axles, nor (3) 60,000 pounds total gross load for single vehicles or 110,000 pounds total gross load for truck and trailer or semi-trailer combinations.
- B. The loading on bridge structures due to 2 and 3 axle pneumatic-tired earthmovers shall not exceed that shown in the following table.

Allowable Construction Loading On Bridges For 2 and 3 Axle Earthmovers

Spacing of Bridge Girders (center to center in feet)	Maximum Axle Loading (in pounds)
4	28,000
5	29,000
6	30,0
7	32,000
8	34,000
9	37,000
10 and over	40,000

Minimum axle spacing:

For 3-axle earthmovers

Axles 1 to 2 = 8 feet

Axles 2 to 3 = 20 feet

For 2-axle earthmovers

Axles 1 to 2 = 20 feet

- 4. Move equipment within the limits of the project over completed or existing base, surfacing, pavement and structures, whether or not open to the public.
- d. Within the limits of the project and subject to the condition that the Contractor shall repair, at the Contractor's expense, any damage caused thereby, the Contractor will be permitted to cross culverts and pipes with construction equipment that exceeds the size or weight limitations set forth in Division 15 of the Vehicle Code in accordance with the conditions set forth on the Project Plans.
- e. Should the Contractor desire to increase the load carrying capacity of a structure or structures which are to be constructed as a part of the Agreement, in order to facilitate the Contractor's own operations, the Contractor may request the Engineer to consider redesigning the structure or structures. Proposals by the Contractor to increase the load carrying capacity of structures above 130,000

pounds per single axle or pair of axles less than 8 feet apart, or above 330,000 pounds total gross vehicle weight, will not be approved. The request shall include a description of the structure or structures involved and a detailed description of the overloads to be carried, the date the revised plans would be required, and a statement that the Contractor agrees to pay all costs involved in the strengthening of the structure or structures, including the cost of revised plans, and further that the Contractor agrees that no extension of time will be allowed by reason of any delay to the work which may be due to the alteration of the structure or structures. If the Engineer determines that strengthening the structure or structures will be permitted, the Engineer will inform the Contractor of the estimated cost of the alterations, including engineering, and the date that revised plans could be furnished. If the cost and date are satisfactory to the Contractor, the Engineer will prepare a change order providing for the agreed upon alterations.

6-1.16 Public Convenience.

- a. The Contractor shall so conduct operations as to offer the least possible obstruction and inconvenience to the public and shall have under construction no greater length or amount of Work than can be prosecuted properly with due regard to the rights of the public.
- b. Unless otherwise provided in the Special Provisions, all public traffic shall be permitted to pass through the Work with as little inconvenience and delay as possible. Where possible, public traffic shall be routed on new or existing paved surfaces.
- c. Spillage resulting from hauling operations along or across any public traveled way shall be removed immediately by the Contractor at the Contractor's expense.
- d. Existing traffic signals and highway lighting shall be kept in operation for the benefit of the traveling public during progress of the Work, and other forces will continue routine maintenance of existing systems.
- e. Construction operations shall be conducted in such a manner as to cause as little inconvenience as possible to abutting property owners.
- f. Convenient access to driveways, houses, and buildings along the line of the Work shall be maintained and temporary approaches to crossings or intersecting highways shall be provided and kept in good condition. When the abutting property owner's access across the right of way line is to be eliminated, or to be replaced under the contract by other access facilities, the existing access shall not be closed until the replacement access facilities are usable.

- g. The Contractor may be required to cover certain signs which regulate or direct public traffic to roadways that are not open to traffic. The Engineer will determine which signs shall be covered.
- h. Roadway excavation and the construction of embankments shall be conducted in such a manner as to provide a reasonably smooth and even surface satisfactory for use by public traffic at all times; sufficient fill at culverts and bridges to permit traffic to cross shall be placed in advance of other grading operations; and if ordered by the Engineer roadway cuts shall be excavated in lifts and embankments constructed part width at a time, construction being alternated from one side to the other and traffic routed over the side opposite the one under construction. Culvert installation or culvert construction shall be conducted on but one-half the width of the traveled way at a time, and that portion of the traveled way being used by public traffic shall be kept open and unobstructed until the opposite side of the traveled way is ready for use by traffic.
- i. Upon completion of rough grading at the grading plane, or placing any subsequent layer thereon, the surface of the roadbed shall be brought to a smooth, even condition free of humps and depressions, satisfactory for the use of public traffic.
- j. After the surface of the roadbed has been brought to a smooth and even condition for the passage of public traffic as above provided, any work ordered by the Engineer for the accommodation of public traffic prior to commencing subgrade operations will be paid for as extra work as provided in Section 3. After subgrade preparation for a specified layer of material has been completed, the Contractor shall, at the Contractor's expense, repair any damage to the roadbed or completed subgrade, including damage caused by the Contractor's operations or use by public traffic.
- k. While subgrade and paving operations are underway, public traffic shall be permitted to use the shoulders and, if half-width paving methods are used, shall also be permitted to use the side of the roadbed opposite the one under construction. When sufficient width is available, a passageway wide enough to accommodate at least 2 lanes of traffic shall be kept open at locations where subgrade and paving operations are in active progress.
- l. When ordered by the Engineer, the Contractor shall furnish a pilot car and driver and flaggers for the purpose of expediting the passage of public traffic through the Work under one-way controls. At locations where traffic is being routed through construction under one-way controls and when ordered by the Engineer, the movement of the Contractor's equipment from one portion of the Work to another shall be governed in accordance with the one-way controls.

- m. Water or dust palliative shall be applied if ordered by the Engineer for the alleviation or prevention of dust nuisance.
- n. In order to expedite the passage of public traffic through or around the work and where ordered by the Engineer, the Contractor shall install signs, lights, flares, temporary railing (Type K), barricades and other facilities for the sole convenience and direction of public traffic. Also where directed by the Engineer, the Contractor shall furnish competent flaggers whose sole duties shall consist of directing the movement of public traffic through or around the Work. The cost of furnishing and installing the signs, lights, flares, temporary railing (Type K), barricades, and other facilities, not to be paid for as separate contract items, will be paid for as provided in Section 3.
- o. The Contractor will be required to pay the cost of replacing or repairing all facilities installed for the convenience or direction or warning of public traffic that are lost while in the Contractor's custody, or are damaged by reason of the Contractor's operations to such an extent as to require replacement or repair, and deductions from any moneys due or to become due the Contractor will be made to cover the cost.
- p. Whenever a section of surfacing, pavement or the deck of a structure has been completed, the Contractor shall open it to use by public traffic if the Engineer so orders or may open it to use by public traffic if the Engineer so consents. In either case the Contractor will not be allowed any compensation due to any delay, hindrance or inconvenience to the Contractor's operations caused by public traffic, but will thereupon be relieved of responsibility for damage to completed permanent facilities caused by public traffic, within the limits of that use. The Contractor will not be relieved of any other responsibility under the contract nor will the Contractor be relieved of cleanup and finishing operations.
- q. Except as otherwise provided in this Section 6.1-16 or in the Special Provisions, full compensation for conforming to the provisions in this Section 6.1-16 shall be considered as included in the prices paid for the various contract items of work and no additional compensation will be allowed therefore.

6-1.17 Public Safety.

- a. It is the Contractor's responsibility to provide for the safety of traffic and the public during construction.
- b. Whenever the Contractor's operations create a condition hazardous to traffic or to the public, the Contractor shall, at the Contractor's expense and without cost to the District, furnish, erect and maintain those fences, temporary railing (Type K), barricades, lights, signs and other devices and take such other protective

measures that are necessary to prevent accidents or damage or injury to the public.

- c. Fences, temporary railing (Type K), barricades, lights, signs, and other devices furnished, erected and maintained by the Contractor, at the Contractor's expense, are in addition to any construction area traffic control devices for which payment is provided for elsewhere in the Agreement.
- d. The Contractor shall also furnish such flaggers as are necessary to give adequate warning to traffic or to the public of any dangerous conditions to be encountered.
- e. Signs, lights, flags, and other warning and safety devices and their use shall conform to the requirements set forth in Chapter 6 of the MUTCD. Signs or other protective devices furnished and erected by the Contractor, at the Contractor's expense, as above provided, shall not obscure the visibility of, nor conflict in intent, meaning and function of either existing signs, lights and traffic control devices or any construction area signs and traffic control devices for which furnishing of, or payment for, is provided elsewhere in the Agreement. Signs furnished and erected by the Contractor, at the Contractor's expense, shall be approved by the Engineer as to size, wording and location.
- f. The installation of general roadway illumination shall not relieve the Contractor of the responsibility for furnishing and maintaining any of the protective facilities herein before specified.
- g. Construction equipment shall enter and leave the highway via existing ramps and crossovers and shall move in the direction of public traffic. All movements of workmen and construction equipment on or across lanes open to public traffic shall be performed in a manner that will not endanger public traffic.
- h. The Contractor's trucks or other mobile equipment which leave a freeway lane, that is open to public traffic, to enter the construction area, shall slow down gradually in advance of the location of the turnoff to give following public traffic an opportunity to slow down.
- i. When leaving a Work area and entering a roadway carrying public traffic, the Contractor's equipment, whether empty or loaded, shall in all cases yield to public traffic.
- j. Lanes, ramps and shoulders shall be closed in accordance with the details shown on the plans, and as provided in the Special Provisions.

- k. The Contractor shall notify the Engineer not less than 18 days and not more than 90 days prior to the anticipated start of an operation that will change the vertical or horizontal clearance available to public traffic (including shoulders).
- l. Pedestrian openings through falsework shall be paved or provided with full width continuous wood walks and shall be kept clear. Pedestrians shall be protected from falling objects and curing water for concrete. Overhead protection for pedestrians shall extend not less than 4 feet beyond the edge of the bridge deck. All pedestrian openings through falsework shall be illuminated.
- m. When vertical clearance is temporarily reduced to 15 feet, or less, low clearance warning signs shall be placed in accordance with Chapter 2 of the MUTCD and as directed by the Engineer. Signs shall conform to the dimensions, color, and legend requirements of the MUTCD, and these specifications except that the signs shall have black letters and numbers on an orange retroreflective background. W12-2P signs shall be illuminated so that the signs are clearly visible.
- n. No material or equipment shall be stored where it will interfere with the free and safe passage of public traffic, and at the end of each day's Work and at other times when construction operations are suspended for any reason, the Contractor shall remove all equipment and other obstructions from that portion of the roadway open for use by public traffic.
- o. Temporary facilities which the Contractor uses to perform the Work shall not be installed or placed where they will interfere with the free and safe passage of public traffic.
- p. Temporary facilities which could be a hazard to public safety if improperly designed shall comply with design requirements specified in the Agreement for those facilities or, if none are specified, with standard design criteria or codes appropriate for the facility involved. Working drawings and design calculations for the temporary facilities shall be prepared and signed by an engineer who is registered as a Civil Engineer in the State of California and shall be submitted to the Engineer for approval. The submittals shall designate thereon the standard design criteria or codes used. Installation of the temporary facilities shall not start until the Engineer has reviewed and approved the drawings.
- q. Should the Contractor appear to be neglectful or negligent in furnishing warning devices and taking protective measures as above provided, the Engineer may direct attention to the existence of a hazard and the necessary warning devices shall be furnished and installed and protective measures taken by the Contractor at the Contractor's expense. Should the Engineer point out the inadequacy of warning devices and protective measures, that action on the part of the Engineer

shall not relieve the Contractor from responsibility for public safety or abrogate the obligation to furnish and pay for these devices and measures.

- r. Provision for the payment for signs, lights, flares, temporary railing (Type K), barricades, and other facilities as provided in Section 6-1.16, "Public Convenience," or by contract item, shall in no wise relieve the Contractor from the responsibility as provided in this Section 6-1.17.
- s. Except as otherwise provided in this Section 6-1.17 or in the special provisions, full compensation for conforming to all of the provisions in this Section 6-1.17 shall be considered as included in the prices paid for the various contract items of Work and no additional compensation will be allowed therefore.

6-1.18 Preservation of Property.

- a. Roadside trees, shrubs and other plants that are not to be removed, and pole lines, fences, signs, markers and monuments, buildings and structures, conduits, pipelines under or above ground, sewer and water lines, all highway facilities and any other improvements or facilities within or adjacent to the highway shall be protected from injury or damage, and if ordered by the Engineer, the Contractor shall provide and install suitable safeguards, approved by the Engineer, to protect the objects from injury or damage. If the objects are injured or damaged by reason of the Contractor's operations, the objects shall be replaced or restored at the Contractor's expense. The facilities shall be replaced or restored to a condition as good as when the Contractor entered upon the Work, or as good as required by the Agreement, if any of the objects are a part of the Work. The Engineer may make or cause to be made those temporary repairs that are necessary to restore to service any damaged highway facility. The cost of the repairs shall be borne by the Contractor and may be deducted from any moneys due or to become due to the Contractor under the contract.
- b. The fact that any underground facility is not shown upon the Project Plans shall not relieve the Contractor of the responsibility under Section 4-1.05, "Utility and Non-Highway Facilities." It shall be the Contractor's responsibility, pursuant thereto, to ascertain the location of those underground improvements or facilities which may be subject to damage by reason of the Contractor's operations.
- c. Full compensation for furnishing all labor, materials, tools, equipment, and incidentals, and for doing all the Work involved in protecting or repairing property as specified in this Section 6-1.18, shall be considered as included in the prices paid for the various contract items of Work and no additional compensation will be allowed therefore.

6-1.19 Sound Control Requirements. The Contractor shall comply with all local sound control and noise level rules, regulations and ordinances which apply to any Work

performed pursuant to the Agreement. Each internal combustion engine, used for any purpose on the job or related to the job, shall be equipped with a muffler of a type recommended by the manufacturer. No internal combustion engine shall be operated on the project without the muffler.

6-1.20 Disposal Of Material Outside The Right Of Way.

- a. If the Contractor elects to dispose of materials at locations other than those where arrangements have been made by the District, or, if material is to be disposed of and the District has not made arrangements for disposal of the material, the Contractor shall make arrangements for disposing of the materials outside the highway right of way and shall pay all costs involved. Arrangements shall include, but not be limited to, entering into agreements with property owners and obtaining necessary permits, licenses and environmental clearances. Before disposing of any material outside the highway right of way, the Contractor shall furnish to the Engineer satisfactory evidence that the Contractor has entered into agreements with the property owners of the site involved and has obtained the permits, licenses and clearances.
- b. When any material is to be disposed of outside the highway right of way, and the District has not made arrangements for disposal of the material, the Contractor shall first obtain written authorization from the property owner on whose property the disposal is to be made and the Contractor shall file with the Engineer the authorization or a certified copy thereof together with a written release from the property owner absolving the District from any and all responsibility in connection with the disposal of material on the property. Before any material is disposed of on the property, the Contractor shall obtain written permission from the Engineer to dispose of the material at the location designated in the authorization. When material is disposed of as above provided and the disposal location is visible from a highway, the Contractor shall dispose of the material in a neat and uniform manner to the satisfaction of the Engineer.
- c. Where the District has made arrangements with owners of land in the vicinity of a project for the disposal of materials on an owner's property, the arrangements are made solely for the purpose of providing all bidders an equal opportunity to dispose of the materials on the property. Bidders or Contractors may, upon written request, inspect the documents evidencing the arrangements between property owners and the District. The Contractor may, if the Contractor so elects, exercise any rights that have been obtained, which may be exercised by a Contractor under the arrangements, subject to and upon the conditions hereinafter set forth.
- d. Such arrangements are not a part of the Agreement and it is expressly understood and agreed that the District assumes no responsibility to the Contractor whatsoever in respect to the arrangements made with the property owner to dispose of materials thereon and that the Contractor shall assume all risks in connection with the use of the property, the terms upon which the use shall be made, and there is no warranty

or guaranty, either express or implied, as to the quantity or types of materials that can be disposed of on the property.

- e. In those instances in which the District has compiled "Materials Information" as referred to in Section 3, "Examination of Plans, Specifications, Contract, and Site of Work," of Instructions to Bidders, the compilation will include the documents setting forth the arrangement made with some of the property owners for the disposal of material on those owners' properties. The inclusion of the documents therein shall not in any respect operate as a waiver of any of the provisions in this Section 6-1.20 concerning the documents.
- f. The Contractor is cautioned to make such independent investigation and examination as the Contractor deems necessary to be satisfied as to the quantity and types of materials which may be disposed of on the property and the rights, duties and obligations acquired or undertaken under the arrangement with the property owner.
- g. Notwithstanding that the Contractor may elect to dispose of materials on any such property owner's property, no material may be disposed of on that property unless the Contractor has first either:
 - 1. Executed a document that will guarantee to hold the owner harmless from all claims for injury to persons or damage to property resulting from the Contractor's operations on the property owner's premises and also agree to conform to all other provisions set forth in the arrangement made between the District and the property owner. The document will be prepared by the Engineer for execution by the Contractor, or
 - 2. Entered into an agreement with the owner of the disposal site on any terms mutually agreeable to the owner and the Contractor; provided that the Contractor shall furnish to the Engineer a release, in a form satisfactory to the Engineer, executed by the owner, relieving the District of any and all obligations under the District's arrangement with the owner.
- h. If the Contractor elects to dispose of material under (1), the use of the site shall be subject to the terms, conditions and limitations of the arrangement made between the property owner and the District and the Contractor shall pay those charges that are provided for in the arrangement made by the District with the property owner, and deductions will be made from any moneys due or that may become due the Contractor under the contract sufficient to cover the charges for the material disposed of.
- i. If the Contractor elects to dispose of material under (2), the Contractor shall pay those charges that are provided for in the agreement between the owner and the

Contractor and deductions will not be made from any moneys due or that may become due the Contractor under the contract to cover the charges.

- j. The Engineer may require the Contractor to submit written evidence that the owner of the disposal site is satisfied that the Contractor has satisfactorily complied with the provisions of either - (1), the arrangement between the Department and the owner, or (2), the agreement between the owner and the Contractor, as the case may be.
- k. Full compensation for all costs involved in disposing of materials as specified in this Section 6-1.20, including all costs of hauling, shall be considered as included in the price paid for the contract item of work involving the materials and no additional compensation will be allowed therefore.

6.1-21 Assignment of Unfair Business Practice Claims. In accordance with California Public Contract Code Section 7103.5, the Contractor and any subcontractors offer and agree to assign to the District all rights, title, and interest in and to all causes of action the Contractor or any subcontractors may have under Section 4 of the Clayton Act (15 U.S.C. § 15) or under the Cartwright Act (Chapter 2 (commencing with § 16700) of Part 2 of Division 7 of the Business and Professions Code), arising from purchases of goods, services or materials pursuant to this contract. This assignment shall be made and become effective at the time the District tenders final payment to the Contractor, without further acknowledgement by the parties.

6-1.22 Notice of Potential Claim

- a. If for any reason the Contractor deems that additional compensation is due for Work or materials not clearly provided for in the Agreement, Project Plans or Technical Specifications or previously authorized extra work, a Notice of Potential Claim shall be made. The Contractor shall give the Engineer a written Notice of Potential Claim concerning such additional compensation before Work begins on the items on which the claim is based. The notice shall set forth the reasons for which the Contractor believes additional compensation will or may be due and the nature of the costs involved. Any Notice of Potential Claim submitted to the District by the Contractor shall have attached the following certification executed by an officer of the Contractor:

I, _____, being the _____ of _____ (Contractor), declare under penalty of perjury under the laws of the State of California, and do personally certify and attest that: I have thoroughly reviewed the attached claim and know its contents, and said claim is made in good faith; that it is supported by truthful and accurate data; that the amount requested accurately reflects the contract adjustment for which the Contractor believes the District is liable; and further, that I am familiar with California Penal Code section 72 and California Government Code section 12650, et seq., pertaining to false claims, and

further know and understand that submission or certification of a false claim may lead to fines, imprisonment, or other severe legal consequences.

- b. The Contractor shall afford the Engineer every opportunity and facility for keeping records of actual cost of the work. The Contractor shall keep records of the disputed work in accordance with Section 3-1.17, Change Order Pricing.
- c. If such notification is not given or the Engineer is not afforded proper opportunity by the Contractor for keeping strict account of actual cost as required, then the Contractor hereby agrees to waive any claim for such additional compensation. Such notice by the Contractor and the fact that the Engineer has kept account of the cost of the Work shall not in any way be construed as proving or substantiating the validity of the claim. When the Work on the which the claim for additional compensation is based has been completed, the Contractor shall within 10 calendar days of completion submit the Contractor's written claim to the Engineer, who will present it to the District for consideration in accordance with the Agreement, including, but not limited to Section 11-1.03 of the General Provisions and applicable law.
- d. Any claim for overhead type expense or costs, in addition to being certified as stated above, shall be supported by an audit report of an independent Certified Public Accountant. Any claim for overhead shall also be subject to audit by the District at its discretion.
- e. Any costs or expenses incurred by the District in reviewing or auditing any claims that are not supported by the Contractor's cost accounting or other records shall be deemed to be damages incurred by the District within the meaning of the California False Claims Act.

SECTION 7 MEASUREMENT AND PAYMENT

7-1.01 F.O.B. All shipments must be F.O.B. destination to the Work site and/or other sites indicated in the Contract Documents. The Contract Price is all-inclusive (including sales tax). There shall be no additional compensation paid for containers, packing, unpacking, drayage or insurance. The Contract Prices includes full compensation for all taxes which the Contractor is required to pay, whether imposed by Federal, State or local government, including, without being limited to, Federal excise tax. No tax exemption certificate nor any document designed to exempt the Contractor from payment of any tax will be furnished to the Contractor by the District, as to any tax on labor, services, materials, transportation, or any other items furnished pursuant to this Agreement.

7-1.02 Payment.

- a. On or about the first day of each calendar month the Contractor will submit to the Engineer a verified application for payment and schedule of values supported by a statement showing all materials actually installed during the preceding month and the cost of labor actually expended in the performance of the Work. Unless otherwise provided in the Contract Documents, no allowances or payments will be made for material or equipment not placed at the Work site. Each invoice shall contain the following certification executed by a duly authorized officer of the Contractor:

I, _____, being the _____ of _____ (Contractor), declare under penalty of perjury under the laws of the State of California, and do personally certify and attest that: I have thoroughly reviewed the attached application for payment and know its contents, and said application is made in good faith; that it is supported by truthful and accurate data; that the amount requested accurately reflects the costs incurred during the period covered by this application; and further, that I am familiar with California Penal Code section 72 and California Government Code section 12650, et seq., pertaining to false claims, and further know and understand that submission or certification of a false claim may lead to fines, imprisonment, or other severe legal consequences.

- b. To be eligible for payment, the Contractor's applications for payment must include certified payroll reports prepared in accordance with California Labor Code Section 1776 and the Agreement for each employee of the Contractor and any subcontractors engaged in the performance of the Work during the preceding months. Applications for payment will not be processed without certified payroll reports.

- c. In accordance with California Public Contract Code Section 20104.50, the District will review applications for payment as soon as practicable after receipt. Any application or part of an application that is determined to be improper will be returned to the Contractor as soon as practicable, but no later than seven days after receipt by the District, along with a written description of the reasons why the application is improper. The Contractor's failure to submit a schedule in the time specified in Section 3-1.10 or its submission of a schedule to which the District has taken any uncorrected exception, shall serve as a basis for returning an application for payment in its entirety.
- d. Unless the Contractor has elected to post securities in lieu of retention in accordance with California Public Contract Code Section 22300 and the Agreement, and the Contractor and the District have executed an escrow agreement in accordance with Public Contract Code Section 22300 and the Agreement, the District will make progress payments to the Contractor in accordance with applicable law in the amount of ninety five (95) percent of the value of the labor actually performed and the material incorporated in the Work as specified in Contractor's verified application for payment upon approval by the District's authorized representative(s). Payment of progress payments will not be construed as acceptance of the Work performed. If the Contractor has elected to post securities in lieu of retention in accordance with Public Contract Code Section 22300 and the Agreement and the Contractor and the District have executed an escrow agreement in accordance with Public Contract Code Section 22300 and the Agreement, the District will make payments to the Contractor or the Contractor's escrow agent in accordance with such escrow agreement.
- e. The District will pay the Contractor's final invoice in accordance with applicable law and this Section 7 following acceptance of the Work provided that:
 - 1. The Contractor has furnished evidence satisfactory to the District that all claims for labor and material have been paid, or the time for filing valid stop notices has passed and no stop notices have been filed, or all stop notices filed have been released by valid release or release bond acceptable to the District.
 - 2. No claim has been presented to the District by any person based upon any acts or omissions of the Contractor or any subcontractor engaged in the performance of the Work.
 - 3. No other claim or dispute exists under the Agreement or applicable law concerning payment of the Contractor's final invoice and/or release of the Agreement retention.
 - 4. The Contractor has filed with the District the Maintenance Bond provided in the Contract Documents with duly notarized signatures of an authorized representative of the Contractor and an attorney-in-fact of an admitted surety

insurer acceptable to the District and such Maintenance Bond binds the Contractor as Principal and the Surety in accordance with its terms in the amount of 10% of the final Contract Price.

- f. In accordance with California Public Contract Code Section 20104.50, if the District fails to make a progress payment within thirty (30) days of receipt of an undisputed, properly submitted application for payment, the District will pay the Contractor interest equivalent to the legal rate set forth in subdivision (a) of California Code of Civil Procedure Section 685.010. The number of days available to the District to make a payment without incurring an interest obligation pursuant to this provision and California Public Contract Code Section 20104.50 will be reduced by the number of days, if any, by which the District has delayed return of an application for payment beyond the seven day return requirement set forth in Section 7-1.02.

7-1.03 Non-Allowable Direct Charges. The following costs are not allowable direct charges under the Agreement. The following costs may only be paid under the Agreement, if at all, as part of any allowance for Contractor overhead and/or profit established under the Agreement.

- a. Labor costs in excess of applicable prevailing wages pursuant to the Agreement and applicable law, liability and workers compensation insurance, social security, retirement and unemployment insurance and other employee compensation and benefits pursuant to bona fide compensation plans in effect at the time specified for the opening of Project bids for Contractor and subcontractor employees engaged in the performance of the Work. However, in no event will allowable direct labor charges under the agreement include employee bonuses, employee vehicles or vehicle allowances, employee telephones or telephone allowances, or employee housing or housing allowances, whether or not such benefits are part of a bona fide compensation plan in effect at the time specified for the opening of Project bids.
- b. Superintendent labor and clerical labor.
- c. Bond premiums.
- d. Insurance in excess of that required under Section 6-1.08.
- e. Utility costs.
- f. Work Site office expenses.
- g. Home office expenses.

7-1.04 Retention. The District or its agent may, in accordance with the Contract Documents and applicable law, withhold any payment of monies due or that may become due the Contractor because of:

- a. Defective work not remedied or uncompleted work.
- b. Claims filed or reasonable evidence indicating probable filing of claims.

- c. Failure to properly pay subcontractors or to pay for material or labor.
- d. Reasonable doubt that the Work can be completed for the balance then unpaid.
- e. Damage to another contractor.
- f. Damage to the District.
- g. Damage to a third party.
- h. Delay in the progress of the Work, which, in the District's judgment, is due to the failure of the Contractor to properly expedite the Work.
- i. Liquidated damages or other charges that apply to the Contractor under the Agreement.
- j. Any other lawful basis for withholding payment under the contract.

7-1.05 Securities in Lieu of Retention.

- a. In accordance with Public Contract Code Section 22300, except where federal regulations or polices do not permit substitution of securities, the Contractor may substitute securities for any moneys withheld by the District to ensure performance of the Work. At the Contractor's request and expense, securities equivalent to the amount withheld will be deposited with the District, or with a state or federally chartered bank in California as the escrow agent, who will then pay those moneys to the Contractor under the terms of an Escrow for Security Deposit agreement. The Escrow for Security Deposit agreement is provided in the Contract Documents. Upon satisfactory completion of the Work, the securities will be returned to the Contractor.
- b. Alternatively, at the Contractor's request and expense, the District will pay retentions earned directly to the escrow agent. At the Contractor's expense, the Contractor may direct investment of the payments into securities. Upon satisfactory completion of the Work, the Contractor will receive from the escrow agent all securities, interest, and payments received by the escrow agent from the District pursuant to this provision and the terms of the Escrow for Security Deposit agreement. The Contractor will, within 20 days of receipt of payment, pay to each subcontractor the respective amount of interest earned, less costs of retention withheld from each Subcontractor, on monies withheld to ensure the Contractor's performance of the Work.
- c. Securities eligible for investment in accordance with this provision include those listed in Government Code Section 16430, bank or savings and loan certificates of deposit, interest bearing demand deposit accounts, standby letters of credit, or any other security mutually agreed to by the Contractor and the District.
- d. The Contractor will be the beneficial owner of any securities substituted for moneys withheld and will receive any interest thereon.

SECTION 8

PROJECT ACCEPTANCE AND CLOSEOUT

8-1.01 Occupancy. The District reserves the right to occupy or use any part or parts or the entire of the Work before the Work is fully performed. Subject to applicable law, exercising this right will in no way constitute acceptance of any part of the Work so occupied or used or acceptance of the entire Work, nor will such occupancy or use in any way affect the times when payments will become due the Contractor, nor will such occupancy or use in any way prejudice the District's rights under the Agreement, any Agreement bonds, or at law or equity. Occupancy or use shall not waive the District's rights to assess liquidated damages in accordance with Section 5 after the date of such occupancy or use.

8-1.02 Work Completion and Final Inspection. When the Contractor considers the Work is completed, the Contractor will submit written certification to the Engineer specifying that: the Contract Documents have been reviewed; the Work has been inspected for compliance with the Contract Documents; the Work has been completed in accordance with the Contract Documents; and that equipment and systems have been tested in the presence of the District's representative and are operational. The District and/or the District's authorized representatives will make an inspection to verify that the Work is complete and will notify the Contractor in writing of any incomplete or deficient Work. The Contractor will take immediate steps to remedy the stated deficiencies and give notice of correction to the Engineer. Upon receiving a notice of correction, the District or the District's authorized representatives will re-inspect the Work. The Contractor must correct all punch list items within 15 working days after the issuance of the punch list. Before acceptance of the Work the Contractor must submit: one set of the Project Record Drawings (As-Built), and any equipment operating and maintenance instructions and data, warranties.

8-1.03 Work Acceptance.

- a. All finished Work will be subject to inspection and acceptance or rejection by the District, the Engineer, and the Designer or other government agencies having jurisdiction over the Work. Final acceptance of the Work will be at the discretion of the District.
- b. The District will accept the Work in writing only when the Work has been completed to the District's reasonable satisfaction. Progress payments will in no way be construed as acceptance of any part of the Work

- c. In evaluating the Work, no allowance will be made for deviations from the Technical Specifications, Project Plans or other Contract Documents unless already approved in writing in accordance with the requirements of Section 3, above.

- d. The fact that the Work and materials have been inspected from time to time and that progress payments have been made does not relieve the Contractor of the responsibility of replacing and making good any defective or omitted work or materials in accordance with the requirements of the Contract Documents.

SECTION 9 REMEDIES AND DISPUTES

9-1.01 Failure to Correct Work. Within ten (10) working days of receiving written notice from the District describing Work that is defective or that is otherwise not in accordance with the requirements of the Agreement and/or applicable law and directing that such Work be corrected, the Contractor and/or the Contractor's sureties must give the District written notice of the intent of the Contractor and/or the Contractor's sureties to correct such Work and commence correction of such Work in accordance with the District's notice and the Agreement. If the Contractor and/or the Contractor's sureties do not give the District written notice of intent to correct such Work and commence correction of such Work within ten (10) working days of receipt of the District's notice, then the District may correct such work and/or have such work corrected for the account and at the expense of the Contractor and/or its sureties, and the Contractor and/or its sureties will be liable to the District for any resulting excess cost. The District may, in addition to all other remedies that the District may have under the Agreement and at law or equity, deduct any such excess cost of completing the Work from amounts that are due or that may become due the Contractor.

9-1.02 Termination.

- a. In accordance with California Public Contract Code Section 7105, in addition to all other available remedies that the District may have under the Agreement, and at law or equity, the District may terminate the Agreement:
 1. If the Contractor or any of its subcontractors engaged in the performance of the Work fails to timely perform the Work and/or any of the Contractor's material obligations under the Contract Documents, including but not limited to submission of an acceptable schedule, that have accrued except for those due to reasons beyond the control of the Contractor pursuant to the Contract Documents.
 2. If the Contractor is adjudged bankrupt, or if it should make a general assignment for the benefit of creditors, or if a receiver should be appointed on account of its creditors.
 3. If the Contractor or any of the subcontractors engaged in the performance of the Work persistently or repeatedly refuses or fails to supply enough properly skilled workmen or proper materials for the timely completion of the Work.
 4. If the Contractor fails to make prompt payment to subcontractors engaged in the performance of the Work or for material or labor used in the

performance of the Work in accordance with the Contract Documents and applicable law.

5. If the Contractor or any subcontractors engaged in the performance of the Work persistently disregards laws or ordinances applicable to the performance of the Work, or the instructions of the District, the Engineer, the Designer, or other authorized representatives of the District.
 6. For any reason or for no reason, at the District's sole discretion.
- b. If the District intends to terminate the Contractor's control of the Work for any of the reasons specified in Section 9-1.02(a) 1 through 5, above, the District will immediately serve written notice to the Contractor and its sureties in accordance with the Contract Documents. Notice of the District's intent to terminate the Agreement will be given by registered or certified mail and specify the grounds for termination, the required cure and the time by which the cure must be effected. Upon receipt of notice of the District's intent to terminate the Agreement for any of the reasons specified in Section 9-1.02(a) 1 through 5, the Contractor will have ten (10) days from receipt of the notice or a longer time specified in the notice to cure its default. If the Contractor does not effect the required cure by the time specified in the notice, the District will issue a written notice of termination to the Contractor and its sureties by registered or certified mail. The notice of termination will specify: that upon receipt of the notice the Contractor's right to perform or complete the Work, including on behalf of the Contractor's sureties, is terminated; that the Contractor's sureties will have the right to take over and complete the Work and perform all of the Contractor's remaining obligations that have accrued under the Agreement; and that if the Contractor's sureties do not both give the District written notice of their intention to take over and perform the Agreement and commence completion of the Work and performance of all of the Contractor's remaining obligations that have accrued under the Agreement within ten (10) days after receipt of notice of termination that the District may declare the Contractor's sureties in default and take over the completion of the Work or have the Work completed for the account and at the expense of the Contractor and its sureties, and the Contractor and its sureties will be liable to the District for any resulting excess cost. The District may, in addition to all other available remedies that the District may have under the Contract Documents and at law or equity, deduct any such excess cost of completing the Work from amounts that are due or that may become due the Contractor.
- c. Upon termination of the Contractor's control of the Work for any of the reasons specified in Section 9-1.02(a) 1 through 5, the Contractor will, if so directed by the District, immediately remove from the Work site any and all materials and personal property belonging to the Contractor which have not been incorporated in the Work and the Contractor and its sureties will be liable upon their bond

for all damages caused the District by reason of the Contractor's failure to complete the Work.

- d. Upon termination of the Contractor's control of the Work for any of the reasons specified in Section 9-1.02(a) 1 through 5, above, the District reserves the right to refuse tender of the Contractor by any surety to complete the Work.
- e. If the District completes or has completed any portion of, or the whole of the Work, following termination of the Contractor's control of the Work for any of the reasons specified in Section 9-1.02(a) 1 through 5, above, the District will neither be liable for nor required to account to the Contractor or the Contractor's sureties in any way for the time within which, or the manner in which such Work is performed, or for any changes made in such Work or for the money expended in satisfying claims and/or suits and/or other obligations in connection with completing the Work. If, following termination of the Contractor's control of the Work for any of the reasons specified in Section 9-1.02(a) 1 through 5, above, the unpaid balance of the Contract Price exceeds the expense of completing the Work, including compensation for additional legal, managerial and administrative services and all other amounts due for the completion of the Work and/or satisfaction of claims of the District and/or others arising out of the Agreement and any other charges that apply to the Contractor under the Agreement, the difference will be paid to the Contractor. If such expenses of completing the Work exceed the unpaid balance of the Contract Price, the Contractor or its sureties will pay the difference to the District.
- f. If the Agreement or Contractor's control of the Work is terminated for any reason, no allowances or compensation will be granted for the loss of any anticipated profit by the Contractor.
- g. In accordance with California Government Code Section 4410, in the event a national emergency occurs, and public work being performed by contract is stopped, directly or indirectly, because of the freezing or diversion of materials, equipment or labor, as the result of an order or a proclamation of the President of the United States, or of an order of any federal authority, and the circumstances or conditions are such that it is impracticable within a reasonable time to proceed with a substantial portion of the Work, then the District and the Contractor may, by written agreement, terminate the Agreement. In accordance with California Government Code Section 4411, such an agreement will include the terms and conditions of the termination of the Contract and provision for the payment of compensation or money, if any, which either party will pay to the other or any other person, under the facts and circumstances in the case. Compensation to the Contractor will be determined on the basis of the reasonable value of the Work done, including preparatory Work. As an exception to the foregoing, in the case of any fully completed separate item or portion of the Work for which there is a separate contract price, the Contract

Price shall control. The parties may in any other case adopt the Contract Price as the reasonable value of the Work or any portion of the Work done.

9-1.03 Disputes.

9-1.03.01 Definitions

For purposes of this section, the following Definitions shall apply:

- A. “Disputed Work” - Work that Contractor contends is outside the scope of the Contract Documents or in violation of the terms of the Contract Documents, resulting from any decision, determination, order, direction, instruction, notice, action, or omission of the District being otherwise incorrect or improper. Disputed Work includes any claims or potential claims regarding loss of productivity, delays, impacts, arising or occurring during the Work, that Contractor may assert resulted from acts or omissions of the District that were outside the requirements of the Contract Documents.
- B. “Good Faith Negotiations” means the successive, tiered negotiations of Disputed Work, each with increasing levels of documentation and substantiation, starting at the Project level and escalating to the Authorized Representative level, then the Executive level, prior to Contractor filing a Final Claim.
- C. “Claim” or “statutory claim” is defined in Public Contract Code section 9104, and means “a separate demand by the contractor sent by registered mail or certified mail with return receipt requested, for one or more of the following:
 - a. A time extension, including, without limitation, for relief from damages or penalties for delay assessed by a public entity under a public works contract.
 - b. Payment by the District of money or damages arising from work done by, or on behalf of, the Contractor pursuant to the contract for a public work and payment for which is not otherwise expressly provided or to which the claimant is not otherwise entitled.
 - c. Payment of an amount that is disputed by the public entity.
- D. Final Claim means the certified Final Claim prepared and submitted by Contractor if Good Faith Negotiations fail to result in settlement of the claim.

9-1.03.02 Requirements of Good Faith Negotiations

A. Introduction

- a. At any time during the Good Faith Negotiations defined in this Section, Contractor may serve a statutory claim pursuant to Public Contract Code section 9204. Upon receipt of a claim pursuant to that section, the District will conduct a reasonable review of the claim and, within a period not to exceed 45 days, shall provide Contractor a written statement identifying what portion of the claim is disputed and what portion is undisputed. Upon receipt of a claim, the District and Contractor may, by mutual agreement,

extend the time period provided in this subdivision. Contractor shall furnish reasonable documentation to support the claim.

- b. Notwithstanding the service of a statutory claim, Contractor must comply with the Good Faith Negotiations procedures defined in this Section. Failure to so comply shall operate as a waiver of Contractor's claims.

B. Notification of Disputed Work Required.

- a. Contractor shall promptly, and before commencing Disputed Work, notify The District's Authorized Representative in writing before proceeding with such Work. Contractor's written notification shall state the objection and the basis of the objection ("Disputed Work").
- b. If Contractor proceeds with the Disputed Work without complying with the written notice requirement, Contractor will be deemed to have assented that the Work is within the Contract's requirements, and shall waive its rights to further right to a protest or Claim.
- c. Contractor shall provide written notice of Disputed Work concurrently with Contractor's incurring any costs it may claim are the responsibility of the District.

C. Contemporaneous Records

- a. Beginning with the first day on which any Disputed Work is performed, and each following Day, Contractor shall maintain detailed hourly records of labor, construction equipment, and services, and itemized records of materials and equipment used each Day in the performance of the Disputed Work. Such records must be of a form acceptable to the District, shall be signed by Contractor, copies provided to the District daily, and are subject to verification by the District.

D. Initial Substantiation (within ten (10) Days after Contractor's first knowledge of the Disputed Work.)

- a. Within ten (10) Days after Contractor's first knowledge of the Disputed Work, Contractor shall provide the District with a written statement of dispute ("Dispute") that includes a preliminary cost proposal for the Disputed Work stating clearly and in detail its objection and reasons for contending the Disputed Work is outside or in breach of the requirements of Contract Documents. The preliminary cost proposal must provide a good faith preliminary estimate of the labor (workers, crews), equipment and/or materials involved, and a corresponding good faith preliminary estimate of cost. It is the responsibility of Contractor to substantiate that the Disputed Work is in fact a change from the base scope of Work.
- b. The written Dispute must identify the subcontractors, vendors, suppliers affected, if any, sufficient for the District to visit the Site to inspect the work and/or conduct a telephonic interview of the persons involved, and/or to photograph the work in question. Contractor shall provide by email digital photographs of the Disputed Work and provide District with contact

information for all involved subcontractors and/or suppliers of any tier to facilitate prompt “in person” review at the next job site meeting.

E. First Negotiation: At Project Level. (No later than twenty-one (21) Days after Contractor’s first knowledge of the Dispute).

- a. The written notice and preliminary cost proposal for Disputed Work must be placed, by Contractor, as either a specific discussion item on the Agenda for the next weekly meeting, or to occur immediately before or following the weekly meeting. Both Owner and Contractor shall then make a good-faith effort to review the Disputed Work. It is expected that discussions will occur no later than twenty-one (21) Days after Contractor’s first knowledge of the Dispute.

F. Updated Dispute Substantiation (no later than thirty (30) days of Contractor’s first knowledge of Disputed Work).

- a. In the event negotiations at the next job site meeting do not result in resolution of the Dispute, and in any event no later than thirty (30) days of Contractor’s first knowledge of Disputed Work, Contractor must update its Dispute (“Updated Dispute”) to meet the following requirements.
- b. Contractor shall submit the Updated Dispute documentation in the following format:
 1. Introduction and Issue Identification
 2. Background
 3. Chronology
 4. Contractor's Position (Reason for County's potential liability)
 5. Supporting documentation of merit
 6. Supporting documentation of damages
 7. Schedules (if appropriate)
 8. Productivity exhibits (if appropriate)
- c. Contractor shall explain, cite by reference to Contract Documents and documents from the Project record and/or submit photocopies of documents supporting the merit of its position.
- d. Contractor shall explain, cite by reference to, and/or submit photocopies of documents supporting damages. Contractor must submit substantial supporting documentation with this Updated Dispute documentation; categories and amounts not identified and justified, will be deemed waived. Contractor may not assert, subsequently, new or different categories or amounts of damages.

G. Second Negotiation: At Project Representative Level. (No later than forty-five (45) Days after Contractor’s first knowledge of the Dispute).

- a. If District and Contractor do not resolve the Disputed Work at their first meeting, then Contractor shall submit its Updated Dispute and shall

calendar the matter for discussion with Contractor's Representative and Owner's Representative to occur within twenty (20) Days of the weekly meeting and no later than forty-five (45) Days after Contractor's first knowledge of the Dispute.

- b. The District's Representative will consider the information provided by Contractor and from District's resources, and will provide a decision in writing. If Contractor disputes the written decision, then Contractor's remedy is to file a Notice of Potential Claim meeting the requirements below.
- c. If for any reason Owner should fail to act or provide a decision on a Dispute or Updated Dispute, all within the required forty-five (45) Days, then the Dispute and Updated Dispute shall be deemed denied by Owner's Representative on the forty-sixth (46th) Day.

H. Notice of Potential Claim (no later than fifty-five (55) Days after Contractor's first knowledge of the Dispute).

- a. If, after receiving District's Representative's decision, Contractor disagrees with it or still considers the Disputed Work required of it to be outside the requirements of the Contract Documents, then Contractor shall so notify District in writing within ten (10) Days after receiving the decision by submitting a Notice of Potential Claim ("NOPC") stating that it will issue a formal claim.

I. Third Negotiation: Meeting of Executives.

- a. Upon receipt of Contractor's NOPC, Contractor and District shall negotiate the claim between and among the Contractor's Representative and Owner's Representative. Negotiations in response to the NOPC will not extend the time to file the Formal Claim.

J. FINAL CLAIM AND CERTIFICATION (Within seventy-five (75) Days of Contractor's first knowledge of a Dispute, or within thirty (30) Days of Owner's written decision on Contractor's Dispute and Updated Dispute.)

- a. Within seventy-five (75) Days of Contractor's first knowledge of a Dispute, or within thirty (30) Days of District's written decision on Contractor's Dispute and Updated Dispute, Contractor shall file with District its formal claim(s), in the form specified in this Section. For each NOPC Contractor intends to pursue as a formal claim, Contractor shall include all arguments, justification, cost or estimates, schedule analysis, and detailed documentation supporting Contractor's position. Contractor is encouraged to designate its Final Claim and Certification as its statutory claim.
- b. Claim Documentation. Contractor's Claim documentation shall conform to generally accepted auditing standards (GAAS). Contractor shall submit the Claim in the following format:
 - 1. Introduction
 - 2. General Background Discussion

3. Summary of Issues and Damages
 4. Index of Issues
 5. For Each Issue (Begin each issue on a new page)
 - a. Background
 - b. Chronology
 - c. Contractor's Position (Reason for County's potential liability)
 - d. Supporting Documentation of Merit
 - e. Supporting Documentation of Damages
 - f. Schedules (if appropriate)
 - g. Productivity exhibits (if appropriate)
- A. Contractor shall explain, cite by reference to, and/or submit photocopies of, documents supporting the merit of its position. Supporting documentation may include, but not be limited to, General Conditions, General Requirements, Technical Specifications, Drawings, correspondence, conference notes, Shop Drawings and other Submittals, Submittal Logs, survey books, inspection reports, delivery schedules, test reports, daily reports, subcontracts, fragmentary Critical Path method schedules, photographs, technical reports, Requests for Information, field instructions, and other related records necessary to support the merit of Contractor's position.
- B. Contractor shall explain, cite by reference to, and/or submit photocopies of, documents supporting damages. Supporting documentation may include, but not be limited to, any or all documents related to the preparation and submission of the Bid; Subcontractor, Supplier or vendor files and cost records; certified payroll reports, materials, equipment, and construction equipment and services costs; purchase orders; invoices; project as planned and as built costs; Subcontractor and Supplier payment documentation; quantity reports; other related records; general ledger and any other accounting materials necessary to support the Contractor's position.

K. CLAIMS SHALL BE CALCULATED IN THE SAME MANNER AS CHANGE ORDERS PER SECTION 01 26 00 (CONTRACT MODIFICATION PROCEDURES). NO SPECIAL, INCIDENTAL OR CONSEQUENTIAL DAMAGES MAY BE CLAIMED, REQUESTED OR RECOVERED.

9-1.03.03 SUBCONTRACTOR CLAIMS.

- A. Contractor shall require each Subcontractor, sub-Subcontractor and supplier to comply with the claims procedure set forth in this Document 00 73 83 to provide Contractor with timely notice and documentation of all claims. Contractor shall present as its claims, all Subcontractor, sub-Subcontractor and supplier claims of any type, and prove them under the terms of the Contract Documents. Owner shall not be directly liable to any Subcontractor, any supplier, or any other person or

organization, or to any surety for or employee or agent of any of them, for damages or extra costs of any type arising out of or resulting from the Project.

9-1.03.04 WRITTEN DECISION AND ACTION ON CLAIMS

Time frames and procedures Decisions on statutory claims and formal claims follow the same procedures stated In Public Contract Code Section 9104:

- a. “Upon receipt of a claim pursuant to this section, the District shall conduct a reasonable review of the claim and, within a period not to exceed 45 days, shall provide the claimant a written statement identifying what portion of the claim is disputed and what portion is undisputed. Upon receipt of a claim, the District and Contractor may, by mutual agreement, extend the time period provided in this subdivision.
- b. If the District needs approval from its governing body to provide the claimant a written statement identifying the disputed portion and the undisputed portion of the claim, and the District does not meet within the 45 days or within the mutually agreed to extension of time following receipt of a claim sent by registered mail or certified mail, return receipt requested, the District shall have up to three days following the next duly publicly noticed meeting of the governing body after the 45-day period, or extension, expires to provide the claimant a written statement identifying the disputed portion and the undisputed portion.
- c. If the claimant disputes the District’s written response, or if the District fails to respond to a claim issued pursuant to this section within the time prescribed, the claimant may demand in writing an informal conference to meet and confer for settlement of the issues in dispute. Upon receipt of a demand in writing sent by registered mail or certified mail, return receipt requested, the District shall schedule a meet and confer conference within 30 days for settlement of the dispute.
- d. Within 10 business days following the conclusion of the meet and confer conference, if the claim or any portion of the claim remains in dispute, the District shall provide the claimant a written statement identifying the portion of the claim that remains in dispute and the portion that is undisputed. Any payment due on an undisputed portion of the claim shall be processed and made within 60 days after the public entity issues its written statement. Any disputed portion of the claim, as identified by the Contractor in writing, shall be submitted to nonbinding mediation, with the District and the claimant sharing the associated costs equally. The District and claimant shall mutually agree to a mediator within 10 business days after the disputed portion of the claim has been identified in writing. If the parties cannot agree upon a mediator, each party shall select a mediator and those mediators shall select a qualified neutral third party to mediate with regard to the disputed portion of the claim. Each party shall bear the fees and costs charged by its respective mediator in connection with the selection of the neutral mediator. If mediation is unsuccessful, the parts of the claim remaining in dispute shall be subject to applicable procedures outside this section.
- e. For purposes of this section, mediation includes any nonbinding process, such as neutral evaluation or a dispute review board, in which an independent third party or board assists the parties in dispute resolution through negotiation or by

issuance of an evaluation. Any mediation utilized shall conform to the timeframes in this section.

- f. Unless otherwise agreed to by the District and the Contractor in writing, the mediation conducted pursuant to this section shall excuse any further obligation under Section 20104.4 of the Public Contract Code to mediate after litigation has been commenced.
- g. Failure by the District to respond to a claim from a Contractor within the time periods described in this subdivision or to otherwise meet the time requirements of this section shall result in the claim being deemed rejected in its entirety. A claim that is denied by reason of the District's failure to have responded to a claim, or its failure to otherwise meet the time requirements of this section, shall not constitute an adverse finding with regard to the merits of the claim or the responsibility or qualifications of the claimant.
- h. Amounts not paid in a timely manner as required by the negotiations required under Public Contract Code section 9204 shall bear interest at 7 percent per annum."

9-1.03.05 CLAIM UPDATES AND WAIVER

- A. Claim Updates Required. If Disputed Work persists longer than a single calendar month, then for each quarter until the Disputed Work ceases, Contractor shall submit to District a document titled "Claim Update" that shall update and quantify all elements of the Claim as completely as possible. Contractor's failure to submit a Claim Update or to quantify costs every quarter shall result in waiver of the Claim for that period. Claims or Claim Updates stating that damages, total damages (direct and indirect), schedule impact and/or any time extension will be determined at a later date shall not comply with this subparagraph and shall result in Contractor waiving its claim(s). Contractor shall also maintain a continuing "claims log" that shall list all outstanding claims and their value, and provide such log to Owner quarterly.
- B. Waiver. If the initially required notice of Dispute, Updated Dispute, Notice of Potential Claim and Final Claim, are not issued within the time period required herein, or if Contractor proceeds with the disputed Work without first having given the notice of the Disputed Work, Contractor shall be deemed to have waived its rights to further claim on the specific issue.

9-1.03.06 GOVERNMENT CODE SECTION 930.2

- A. The procedures, negotiations, record keeping, documentation and Final Claim, if negotiation efforts prove unsuccessful, as required in this Section, are intended to constitute a mandatory administrative remedy and part One of a two-step claim procedure by agreement under California Government Code Section 930.2. Step One is compliance with the Good Faith Negotiations and Claim Requirements. Step Two is filing a Government Code Section 910 Claim in with the County following statutory procedures and identifying Claims submitted, negotiated and not settled.

- B. Should Contractor fail to timely comply with the procedures set forth in this Section, Contractor may have rights to apply for consideration of late claims following the procedures in Government Code Section 930.4. This Section defines the limits of authority of District's representative to consider late claims and the basis therefore.

9-1.03.07 WAIVER AND SUBSTANTIAL COMPLIANCE

- A. If Contractor fails to comply with this Section as to any claim or Disputed Work, then Contractor shall waive its rights to such claim. All claim(s), Disputed Work items or issue(s) not raised in a timely notice, timely notice of potential claim and then timely claim submitted under this Section, may not be asserted in any subsequent arbitration (if subsequently agreed), litigation or legal action, and any award (or portion thereof), judgment or verdict contrary to this preclusion shall be vacated to the extent contrary.
- B. Contractor may request an extension of time to comply with the claims procedure herein, but must do so in advance of time periods expiring and District must give its approval in writing (which approval may be withheld in District's discretion.) As to any other feature of the claim procedure herein (and its claims waiver feature), it may not be waived or altered absent a written Change Order signed by both parties and accepted as to form by their legal counsel (for the District, the Office of the District Attorney.)
- C. The District, in its sole discretion, may consider Contractor's substantial compliance with the required initial notice and written Dispute, provided Contractor demonstrates good faith and a manifest lack of prejudice to District from late written notice, for example, contemporaneous District/Contractor discussions and review of Disputed Work with full opportunity to investigate and verify costs and work performed. Under no circumstances may substantial compliance be considered when the required written notice is more than twenty-one (21) calendar days late.
- D. The District shall not be deemed to waive or alter any provision under this Section, if at District's sole discretion; a claim is administered in a manner not in accord with this Section.
- E. Compliance with the foregoing shall not be a prerequisite to any Claim that is based solely on differences in measurement or errors of computations as to Contract quantities.

9-1.03.07 CLAIMS UNDER \$375,000

- A. The provision of Public Contract Code §20104 set seq. relating to the resolution of construction claims of three hundred seventy-five thousand dollars (\$375,000) or less which arise between a contractor and the District are hereby incorporated in this Contract and are *italicized* for ease of use.
- B. Documentation that is necessary to substantiate Claims submitted pursuant to this section must comply with the format requirements set forth in this Section.

- a. Claims for \$375,000 or below, as provided by Public Contract Code - §20104 (a)-(d), Application of article; provisions included in plans and specifications:
 - (a) (1) *This article applies to all public works claims of three hundred seventy-five thousand dollars (\$375,000) or less which arise between a contractor and local agency.*
 - (2) *This article shall not apply to any claims resulting from a contract between a contractor and a public agency when the public agency has elected to resolve any disputes pursuant to Article 7.1 (commencing with §10240) of Chapter 1 of Part 2.*
 - (b) (1) *"Public work" means "public work contract" as defined in Section 1101 but does not include any work or improvement contracted for by the state or the Regents of the University of California.*
 - (2) *"Claim" means a separate demand by the contractor for (A) a time extension, (B) payment of money or damages arising from work done by, or on behalf of, the contractor pursuant to the contract for a public work and payment of which is not otherwise expressly provided for or the claimant is not otherwise entitled to, or (C) an amount the payment of which is disputed by the local agency.*
 - (c) *The provisions of this article or a summary thereof shall be set forth in the plans or specifications for any work which may give rise to a claim under this article.*
 - (d) *This article applies only to contracts entered into on or after January 1, 1991.*

- C. Claims for \$375,000 or below, as provided by Public Contract Code - §20104.2 (a)-(f), Claims, requirements, tort claims excluded:

For any claim subject to this article, the following requirements apply:

- (a) *The claim shall be in writing and include the documents necessary to substantiate the claim. Claims must be filed on or before the date of Final Payment. Nothing in this subdivision is intended to extend the time limit or supersede notice requirements otherwise provided by contract for the filing of claims.*
- (b) (1) *For claims of less than fifty thousand dollars (\$50,000), the local agency shall respond in writing to any written claim within 45 days of receipt of the claim, or may request, in writing, within 30 days of receipt of the claim, any additional documentation supporting the claim or relating to defenses to the claim the local agency may have against the claimant.*
- (2) *If additional information is thereafter required, it shall be requested and provided pursuant to this subdivision, upon mutual agreement of the local agency and the claimant.*

(3) The local agency's written response to the claim, as further documented, shall be submitted to the claimant within 15 days after receipt of the further documentation or within a period of time no greater than that taken by the claimant in producing the additional information, whichever is greater.

(c) (1) For claims of over fifty thousand dollars (\$50,000) and less than or equal to three hundred seventy-five thousand dollars (\$375,000), the local agency shall respond in writing to all written claims within 60 days of receipt of the claim, or may request, in writing, within 30 days of receipt of the claim, any additional documentation supporting the claim or relating to defenses to the claim the local agency may have against the claimant.

(2) If additional information is thereafter required, it shall be requested and provided pursuant to this subdivision, upon mutual agreement of the local agency and the claimant.

(3) The local agency's written response to the claim, as further documented, shall be submitted to the claimant within 30 days after receipt of the further documentation, or within a period of time no greater than that taken by the claimant in producing the additional information or requested documentation, whichever is greater.

(d) If the claimant disputes the local agency's written response, or the local agency fails to respond within the time prescribed, the claimant may so notify the local agency, in writing, either within 15 days of receipt of the local agency's response or within 15 days of the local agency's failure to respond within the time prescribed, respectively, and demand an informal conference to meet and confer for settlement of the issue in dispute. Upon a demand, the local agency shall schedule a meet and confer conference within 30 days for settlement of the dispute.

(e) Following the meet and confer conference, if the claim or any portion remains in dispute, the claimant may file a claim as provided in Chapter 1 (commencing with Section 900) and Chapter 2 (commencing with Section 910) of Part 3 of Division 3.6 of Title 1 of the Government Code. For purposes of those provisions, the running of the period of time within which a claim must be filed shall be tolled from the time the claimant submits his or her written claim pursuant to subdivision (a) until the time that claim is denied as a result of the meet and confer process, including any period of time utilized by the meet and confer process.

(f) This article does not apply to tort claims and nothing in this article is intended nor shall be construed to change the time periods for filing tort claims or actions specified by Chapter 1 (commencing with Section 900) and Chapter 2 (commencing with Section 910) of Part 3 of Division 3.6 of Title 1 of the Government Code.

D. Claims for \$375,000 or below, as provided by Public Contract Code - § 20140.4(a)-(c), pertaining to Civil action procedures; mediation and arbitration; trial de novo; witnesses:

The following procedures are established for all civil actions filed to resolve claims subject to this article:

(a) *Within 60 days, but no earlier than 30 days, following the filing or responsive pleadings, the court shall submit the matter to nonbinding mediation unless waived by mutual stipulation of both parties. The mediation process shall provide for the selection within 15 days by both parties of a disinterested third person as mediator, shall be commenced within 30 days of the submittal, and shall be concluded within 15 days from the commencement of the mediation unless a time requirement is extended upon a good cause showing to the court or by stipulation of both parties. If the parties fail to select a mediator within the 15-Day period, any party may petition the court to appoint the mediator.*

(b) (1) *If the matter remains in dispute, the case shall be submitted to judicial arbitration pursuant to Chapter 2.5 (commencing with Section 1141.10) of Title 3 of Part 3 of the Code of Civil Procedure, notwithstanding Section 1141.11 of that code. The Civil Discovery Act (Title 4 commencing with Section 2016.010 of Part 4 of the Code of Civil Procedure) shall apply to any proceeding brought under this subdivision consistent with the rules pertaining to judicial arbitration.*

(2) *Notwithstanding any other provision of law, upon stipulation of the parties, arbitrators appointed for purposes of this article shall be experienced in construction law, and, upon stipulation of the parties, mediators and arbitrators shall be paid necessary and reasonable hourly rates of pay not to exceed their customary rate, and such fees and expenses shall be paid equally by the parties, except in the case of arbitration where the arbitrator, for good cause, determines a different division. In no event shall these fees or expenses be paid by state or county funds.*

(3) *In addition to Chapter 2.5 (commencing with Section 1141.10) of Title 3 of Part 3 of the Code of Civil Procedure, any party who after receiving an arbitration award requests a trial de novo but does not obtain a more favorable judgment shall, in addition to payment of costs and fees under that chapter, pay the attorney's fees of the other party arising out of the trial de novo.*

(c) *The court may, upon request by any party, order any witnesses to participate in the mediation or arbitration process.*

E. Claims for \$375,000 or below, as provided by Public Contract Code - §20140.6 (a)-(b), Payment on undisputed portion of claim; interest on arbitration awards or judgments:

(a) *No local agency shall fail to pay money as to any portion of a claim which is undisputed except as otherwise provided in the contract.*

(b) *In any suit filed under Section 20104.4, the local agency shall pay interest at the legal rate on any arbitration award or judgment. The interest shall begin to accrue on the date the suit is filed in a court of law.*

SECTION 10
SPECIAL PROVISIONS



**TECHNICAL SPECIFICATIONS
(Special Provisions)**

For

**WWTP ACCESS ROAD
IMPROVEMENT PROJECT**

August 2020



Prepared By:

A handwritten signature in black ink that reads "Jennifer Melman".

8/07/20

Jennifer Melman, P.E. 62260

Date



1400 Neotomas Avenue
Santa Rosa, CA 95405
(707) 571-8005

SECTION 10 SPECIAL PROVISIONS

10-1 GENERAL

10-1.01 Description of Work: The work in general consists of roadway surface preparation, double chip-sealing and such other items of work as are required to complete the project.

The estimate of the quantities of work to be done is approximate only, being as a basis for the comparison of bids, and the District does not expressly or by implication agree that the actual amount of work will correspond therewith, but reserves the right to increase or decrease the amount or any portion of the work as directed by the District Engineer.

Incidental items of construction necessary to complete the whole work in a satisfactory and acceptable manner as shown on the plans and as provided for in the specifications and not specifically referred to in this section, shall be understood to be furnished by the Contractor.

10-1.02 Construction Limitations: The Contractor will be expected to conduct his operations in a manner which creates a minimum damage to the natural vegetation, paving and gravel areas. Care shall be exercised to avoid hazards that may cause injury to persons, animals or property either during working hours or after work hours, which will include dust control, backfilling trenches or placement of steel plates and temporary fencing as required.

Equipment will be restricted to the immediate area of construction.

Receptacles for construction residue, including oil, cleaning fluids and litter, will be covered. Such residues will be disposed of in a proper manner.

Mufflers and/or baffles will be required on all construction equipment.

Construction activity within the existing right-of-way will be scheduled to minimize traffic inconvenience and safety hazards to motorists, pedestrians and cyclists.

10-1.03 Order of Work: Order of work shall be in accordance with Section 5, "Control of Work," of the Standard Specifications and these Special Provisions.

Attention is directed to "Construction Area Signs and Traffic Control" of these Special Provisions.

10-1.04 Storm Water Pollution Prevention: Attention is directed to the provisions in Section 13, "Water Pollution Control," of the Standard Specifications and these Special Provisions.

The Contractor shall exercise every reasonable precaution to protect streams, lakes, reservoirs, bays, and coastal waters from pollution with fuels, oils, bitumens, calcium chloride and other harmful materials and shall conduct and schedule his operations so as to avoid or minimize muddying and silting of said streams, lakes, reservoirs, bays and coastal waters. Care shall be exercised to preserve roadside vegetation beyond the limits of construction.

Water pollution control work is intended to provide prevention, control and abatement of water pollution to streams, waterways, and other bodies of water, and shall consist of constructing those facilities which may be shown on the plans, specified herein or in the special provisions, or directed by the Engineer.

Before starting any work on the project, the Contractor shall submit, for acceptance by the District Engineer, a program to control water pollution effectively during construction of the project. Such program shall show the schedule for the erosion control work included in the contract and for all water pollution control measures which the Contractor proposes to take in connection with construction of the project to minimize the effects of his operation upon adjacent streams and other bodies of water. The Contractor shall not perform any clearing and grubbing or earthwork on the project, other than that specifically authorized in writing by the Engineer, until such program has been accepted.

The District Engineer will notify the Contractor of the acceptance or rejection of any submitted or revised water pollution control program not more than 5 working days.

10-1.05 Temporary Erosion Control: Temporary erosion control shall consist of, but not be limited to, constructing such facilities and taking such measures as are necessary to prevent, control and abate water, mud, and erosion damage to public and private property as a result of the construction of this project.

Conformance with the requirements of this section shall in no way relieve the Contractor from his responsibilities, as provided in Section 13, "Water Pollution Control," Section 5-1.36, "Property and Facility Preservation," and Section 5-1.39, "Damage Repair and Restoration," of the Standard Specifications.

Temporary erosion control features as are necessary to prevent damage during the winter season shall be constructed and functioning. The Contractor shall construct such supplementary temporary erosion control facilities as are necessary to protect adjacent private and public property.

Temporary erosion control measures shall conform to the current edition of ABAG manual of standards for erosion and sediment control measures and includes, but not limited to the following:

1. The Contractor shall conduct his operations in such a manner that storm runoff will be contained within the project or channeled into the storm drain system which serves the runoff area. Storm runoff from one area shall not be allowed to divert to another runoff area.
2. The roadway shall be kept swept, and spoils from grinding, sawcutting, trenching, etc. and silt, shall be removed daily or as often as needed to prevent spoils and silt from entering the storm drain system and roadside ditches.

10-1.06 Maintaining Traffic: The site of the work shall be enclosed by suitable barricades, signs and lights to warn and protect traffic effectively and shall be in accordance with those procedures as set by the California Manual of Uniform Traffic Control Devices.

Attention is directed to Section 10-2 "Construction Area Signs and Traffic Control" of these Special Provisions.

The Contractor shall provide adequate barricades, signs, warning lights, watchmen and flagmen in accordance with the latest revision of the State of California "Manual for Warning Signs, Lights and Devices for Use in Performing Work Upon Highways" to protect the work and the safety of the public. Warning lights using inflammable liquids will not be permitted; only electrically operated lights will be approved for use. Warning lights shall be kept burning from sunset to sunrise, and barricades shall be painted to increase their visibility at night.

All detours and traffic control shall be between 8:00 a.m. and 5:00 p.m. unless otherwise noted; unobstructed two-way traffic shall be maintained daily from 5:00 p.m. to 8:00 a.m.

Attention is directed to Section 7-1.03, "Public Convenience," and Section 7-1.04, "Public Safety," of the

Standard Specifications, which sections are hereby incorporated in these Special Provisions as if set forth in full. Attention is also directed to Section 10-1.07, "Public Safety," of these Special Provisions.

Adequate traffic control, flagmen, signing, and barricades shall be provided by the Contractor at all times as approved by the Engineer.

10-1.07 Public Safety: The Contractor shall at all times conduct his work in accordance with Construction Safety Orders of the Division of Industrial Safety, State of California, to ensure the least possible obstruction to traffic and inconvenience to the general public, and adequate protection of persons and property in the vicinity of the work.

No access way shall be closed to the public without first obtaining permission of the Engineer.

Should the Contractor fail to provide public safety as specified or if, in the opinion of the Engineer, the warning devices furnished by the Contractor are not adequate, the District may place any warning lights or barricades or take any necessary action to protect or warn the public of any dangerous condition connected with the Contractor's operations and the Contractor shall be liable to the District for all costs incurred including, but not limited to, administrative costs.

Nothing in this section shall be construed to impose tort liability on the District or Engineer.

10-1.08 Water for Construction and Dust Control: Construction and testing water shall conform to Section 17, "Watering," of the Standard Specifications and these Special Provisions. The Contractor shall be responsible for providing all water necessary for construction and testing and disposing of all water needed for testing.

During the performance of the work called for under these Specifications, or any operations appurtenant thereto, the Contractor shall furnish all labor, equipment and means required, and as often as necessary, to prevent his operations from producing dust in amounts damaging to property or causing a nuisance to persons living nearby or occupying buildings in the vicinity.

10-1.09 Protection of Existing Facilities and Property: The Contractor shall notify Underground Service Alert (USA) for marking the locations of existing underground facilities.

The Contractor shall take all necessary measures to avoid injury to existing surface and underground utility facilities in and near the site of the work. No error or omission of utility mark-outs shall be construed to relieve the Contractor from his responsibility to protect all underground pipes, conduits, cables or other structures. The Contractor shall indemnify the District and hold it harmless from any and all claims, demands, or liability made or asserted by any person or entity on account of or in connection with any damage to such surface or underground facilities caused by the Contractor or any of his agents or subcontractors.

The existing underground facilities in the area of work may include but not be limited to telephone, television, communication and electrical cables, sewer pipe and drainage pipe. The various utility companies shall be notified before trenching begins and at such other times as required to protect their facilities. Underground facilities shall be located and exposed ahead of trenching to prevent damage to the facilities, and to determine the depth and character of all facilities that cross or infringe on the trench prism. The Contractor shall immediately notify the District Engineer of any facilities found. If damage should occur to the existing facilities, the utility company and the District shall be notified immediately and repairs acceptable to the utility company shall be made at the Contractor's expense. Contractor shall protect existing utility markers and remove and replace markers as required.

The Contractor shall preserve and protect survey monuments and benchmarks per State of California Business and Professions Code Section 8771.

Attention is directed to the provisions in Section 5-1.36, "Property and Facility Preservation," of the Standard Specifications, which section is hereby incorporated in these special provisions as if set forth in full, and these Special Provisions.

Existing trees, shrubs, and other plants, that are not to be removed and are injured or damaged by reason of the Contractor's operations, shall be replaced by the Contractor in accordance with the requirements in Section 5-1.36, "Property and Facility Preservation," and Section 20-7.03I(16), "Replacement Plants," of the Standard Specifications. Sections 5-1.36 and 20-7.03I(16) of the Standard Specifications is hereby incorporated in these Special Provisions.

10-1.10 Obstructions: Attention is directed to Sections 5-1.36D, "Non-Highway Facilities," and 15, "Existing Facilities," of the Standard Specifications, which sections are hereby incorporated in these Special Provisions as if set forth in full, and these Special Provisions.

Attention is directed to the existence of any overhead and underground power, telephone, and television cable poles, underground sewer mains, and storm drain culverts within the area in which construction is to be performed.

Prior to starting work, the Contractor shall (a minimum of 2 working days in advance) call Underground Service Alert (USA), toll free, at (800) 642-2444 and provide USA with all necessary data relative to the proposed work. USA will accept calls and process information to participating agencies who have underground facilities in the area between the hours of 7:30 a.m. and 5:00 p.m. daily, except Saturdays, Sundays, and holidays. Between the hours of 5:00 p.m. and 7:30 a.m. calls will be recorded and then processed after 7:30 a.m. For emergency situations, after hours and on Saturdays, Sundays and holidays, the Contractor shall contact the organization owning the affected facility. Upon notification, agencies having facilities in the area of the proposed excavation will mark their locations in the field using USA standard colors and codes to identify the facility.

Any delays claimed by the Contractor as a direct result of the utility facilities not being rearranged as provided will not be recognized nor will any delays be considered right-of-way delays within the meaning of Section 8-1.07, "Delays," of the Standard Specifications, except that any such delays will entitle the Contractor to an extension of time as provided in Section 8-1.10, "Liquidated Damages," of the Standard Specifications. The Contractor shall immediately notify the Engineer of such delays.

The Contractor will be required to work around public and private utility facilities and other improvements that are to remain in place within the construction area and he will be held liable to the owners of such facilities or interference with service resulting from his operations.

10-1.11 Hours of Work: The Contractor shall restrict his hours of work to 8:00 a.m. to 5:00 p.m. Monday through Friday. Deviations from these hours may be requested and approved in writing by the Engineer.

10-1.12 Dust Control: Dust control shall conform to the provisions in Section 14-9.03, "Dust Control," of the Standard Specifications, which section is hereby incorporated in these special provisions as if set forth in full, and these Special Provisions.

10-1.13 Preconstruction Conference: Prior to beginning any work, the Contractor shall provide the Engineer and affected agencies with a list of key and responsible personnel and how they may be reached at any time. A preconstruction conference shall be scheduled at least 72 hours prior to construction, at which time the Contractor shall be required to present his proposed work schedule, information of offsite yards,

subcontractors, location of disposal and stockpile areas, and traffic control plans. All such schedules shall be subject to the approval of the Engineer and the applicable agencies.

10-1.14 Referenced Specifications and Standards: All contract work will be in accordance with the District Standards, all other terms of this contract including, but not limited to, these Special Provisions, and applicable law. Provisions of the State Standards and the Standard Specifications will only apply to and be a part of this contract to the extent such provisions are expressly incorporated in these Special Provisions.

10-1.15 Owner Notification: The Contractor shall notify all property owners and businesses affected by the project's work at least 48 hours before work is to begin. The notice shall be in writing, placed on doors and shall indicate the Contractor's name and phone number, type of work, day(s) and time when work will occur. Notice shall be reviewed by the Engineer prior to being posted.

Parking restrictions shall be posted 48 hours in advance along the affected construction areas. See Section 10-2.05 "Removal of On-Street Parking" of these Special Provisions.

10-1.16 Emergency Service Providers Notifications: The Contractor shall furnish the name and phone number of a representative that can be contacted in the event of an emergency. Said information shall be reported to the Lake County Sherriff Department dispatcher and updated as required to provide 24-hour phone access.

10-1.17 Cleanup: Attention is directed to Section 4-1.13, "Cleanup," of the Standard Specifications, which section is hereby incorporated in these Special Provision as if set forth in full.

Before final inspection of the work, the Contractor shall clean the construction site and all ground occupied by him in connection with the work, of all rubbish, excess material, falsework, temporary structures and equipment. All parts of the work shall be left in a neat and presentable condition.

Nothing herein shall require the Contractor to remove warning, regulatory, and guide signs prior to formal acceptance by the Engineer.

10-1.18 Construction Staking: Attention is directed to Section 3-1.11 of the General Provisions for information on Construction Staking.

10-1.19 Tests and Inspections: Attention is directed to Section 3-1.03 of the General Provisions for information on materials testing and inspections.

10-1.20 Payment: Full compensation for conforming to the provisions of this section shall be considered as included in the contract price paid for various other items of work and no additional allowance will be allowed.

10-2 CONSTRUCTION AREA SIGNS & TRAFFIC CONTROL

10-2.01 Construction Area Signs: Temporary construction area signs are required for the direction of public vehicle and pedestrian traffic through or around the work during construction.

Construction area signs shall be furnished, installed, maintained and removed when no longer required in accordance with the provisions in Section 12, "Temporary Traffic Control," of the Standard Specifications, Caltrans Standard Plan T13, the California MUTCD Part 6, and these Special Provisions. Sections 7-1.03, "Public Conveniences," and 7-1.04, "Public Safety," of the Standard Specifications set forth the Contractor's responsibilities for public convenience and public safety are hereby incorporated in these Special Provisions as if set forth in full and are considered to be part of the contract requirements.

Construction area signs shall not be used until they are needed and when no longer needed they shall be removed from the site of the work.

10-2.02 Maintaining Traffic: Attention is directed to Section 7-1.03, "Public Convenience," Section 7-1.04, "Public Safety," and Section 12 "Temporary Traffic Control," of the Standard Specifications, which sections are hereby incorporated in these Special Provisions as if set forth in full. Nothing in these Special Provisions shall be construed as relieving the Contractor from his responsibilities as provided in said Section 7-1.04.

10-2.03 Traffic Control Plan: It is the responsibility of the Contractor to provide a Traffic Control Plan five (5) working days prior to beginning construction. Work shall not begin until the plan is approved by the Engineer.

The content of the Traffic Control Plan shall include, but not be limited to, the following:

- a. Show location and limits of the work zone.
- b. Give dimensions of lanes affected by traffic control that will be open to traffic.
- c. Indicate signing, cone placement, and other methods of delineation and reference to appropriate District or Caltrans standard.
- d. Dimension location of signs and cone tapers.
- e. Identify side streets and driveways affected by construction and show how they will be handled.
- f. Demonstrate how traffic to and from the District's Wastewater Treatment Plant will be maintained.

No work except for the installation of project identification signage will be allowed to commence prior to approval of the work zone Traffic Control Plan.

10-2.04 Contractor Staging Area: Contractor shall not utilize public streets or parking spaces for overnight or weekend storage of vehicles, equipment or materials unless approved by the Engineer.

10-2.05 Measurement and Payment: The contract lump sum price paid for **Traffic Control System** will include full compensation for furnishing all labor (including flagging costs), materials (including signs), Traffic Control Plan, tools, equipment, and incidentals and for doing all the work involved in placing, removing, storing, maintaining, and moving to new locations, replacing, and disposing of the components of the traffic control system as specified in the Standard Specifications and these Special Provisions, and as directed by the Engineer.

10-3 ROADWAY SURFACE PREPARATION

10-3.01 Description: Roadway Surface Preparation will be used where shown on the plans and as directed by the Engineer and shall conform to these specifications. Roadway surface preparation shall consist of grinding/pulverizing of existing chip-seal where present on the roadway, as well as scarifying all remaining road base surfaces to a depth of 2-3 inches. During the scarifying and grinding operations, asphaltic emulsion in accordance with Section 37-3.03B(6) "Tack Coat" of the Standard Specifications. The tack coat should be applied at a rate from 0.15 to 0.20 gals/square yard. Once the tack coat is mixed into the base material, the surface shall be shaped per the typical detail on the plans and compacted to 95%.

10-3.02 Existing Chip-Seal and Roadway Grinding: Chip-seal and existing roadway surface grinding shall be performed with a pavement grinder. All sections of existing chip-seal within the work area, comprising approximately 34,100 square feet, shall be ground.

10-3.03 Shaping: Shape and grade roadway surface to a crowned cross-section with minimum 2% and maximum of 5% cross slopes as indicated on the Plans, or as directed by the Engineer. If any chunking of material over 1-1/2 inches is observed after shaping, it shall be removed to ensure that the ultimate chip seal surface shall be smooth.

10-3.04 Compaction: Compact shaped road surface to 95% relative compaction in accordance with Section 19-5 of the Standard Specifications.

10-3.05 Disposal: The Contractor shall be responsible for recycling or disposal of any removed bituminous pavement in accordance with Section 6-1.20, "Disposal of Material Outside the Right of Way," of the General Provisions.

10-3.06 Measurement and Payment:

Roadway Surface Preparation will be measured by the square yard.

Roadway Surface Preparation will be paid for at the contract price per square yard. Payment shall include full compensation for doing all work involved in as specified herein including labor, materials, tools and equipment, chip-seal grinding, roadway grinding, tack coat application, shaping, compacting, and disposal, as shown on the plans, as specified in these Special Provisions, and as directed by the Engineer and no additional compensation will be allowed.

10-4 CHIP-SEALING

10-4.01 Description: The intent of this project is to provide a Double Chip-Seal over the entire length of the roadway as shown on the plans. As the chip seal will be applied over compacted base rock where a tack coat has been mixed in, it will slightly vary from certain sections of Section 37-2 of the Standard Specifications (primarily roadway preparation.) The Double Chip-Sealing shall consist of a double application of bituminous binder and cover of screenings to be applied in accordance with Section 37-2 of the Standard Specifications and these Special Provisions.

10-4.02 Preparation of Surface: The Contractor shall prepare the surfaces to be chip sealed as specified in Section 10-3, Roadway Surface Preparation, prior to chip sealing. Compensation for surface preparation shall be included in the unit prices paid for Roadway Surface Preparation.

10-4.03 Polymer Modified Asphaltic Emulsion Chip Seal: Chip Sealing shall conform to Section 37-2.03 of the Standard Specifications. Aggregate size shall be 1/2-inch for the initial course and shall be 3/8-inch for the surface (second) course.

10-4.04 Protection of Existing Facilities: The Contractor shall place trimmed construction weight paper or other District approved products over surface facilities such as manhole covers, valve boxes, utility vaults, and survey monuments to prevent the adhesion of chip seal to these facilities. After completion of the chip sealing operations, the Contractor shall remove any chip seal, which may have adhered to the above items.

10-4.05 Finishing: Following application of bituminous binder and screenings, Contractor shall finish the chip seal in accordance with Section 37-2 of the Standard Specifications.

10-4.06 Measurement and Payment:

Chip-Sealing will be measured by the square yard.

Chip-Sealing will be paid for at the contract price per square yard. Payment shall include full compensation for doing all work involved in as specified herein including labor, materials, tools and equipment, protection of existing facilities, applying bituminous coatings and screenings, and finishing, as shown on the plans, as specified in these Special Provisions, and as directed by the Engineer and no additional compensation will be allowed.

10-5 MOBILIZATION

10-6.01 Mobilization: Mobilization shall consist of preparatory work and operations, including, but not limited to, those necessary for the movement of personnel, equipment, supplies and incidentals to the project site; for establishment of all offices and other facilities necessary for work on the project; and for all other work and operations which must be performed or costs incurred prior to beginning work on the various contract items on the project site.

10-6.02 Measurement and Payment: Mobilization will be measured and paid for on a lump sum basis in accordance with the provisions of Section 9-1.16D, "Mobilization," of the Standard Specifications.

PROJECT EXHIBIT DRAWING
(1 Sheet)

ORIGINAL PLOT DATE: 16-JUN-2020

Images: J:\M-516.ppt
Path: F:\C:\30 Projects\394408.dwg\394408.dwg Layout Name: 11x17 Estb Plot Date: Aug 07, 2020 at 02:33 pm

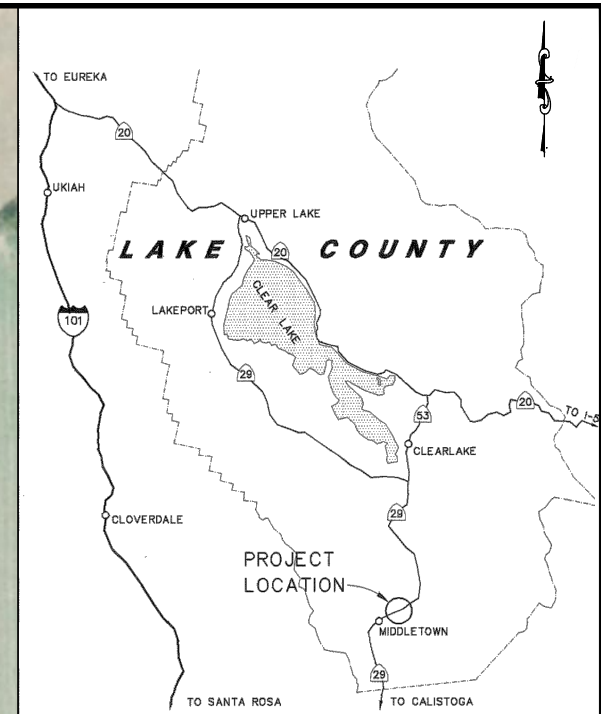
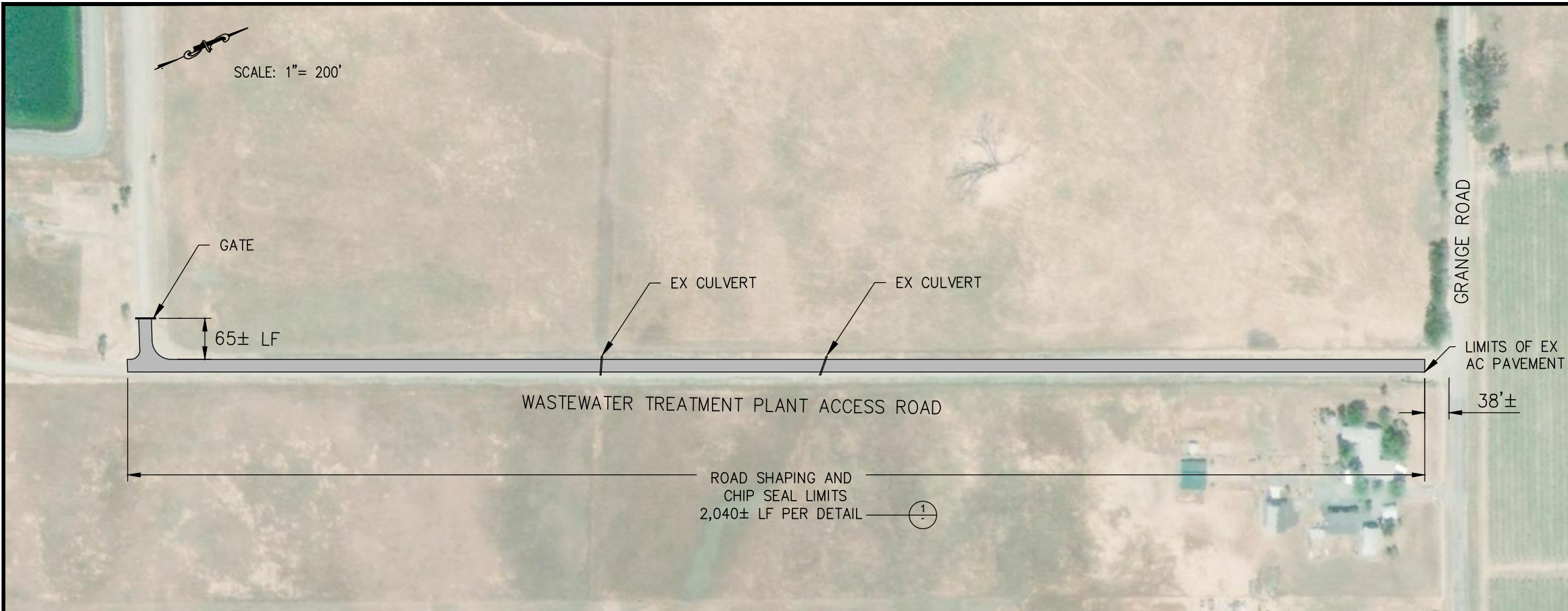

LOCATION MAP

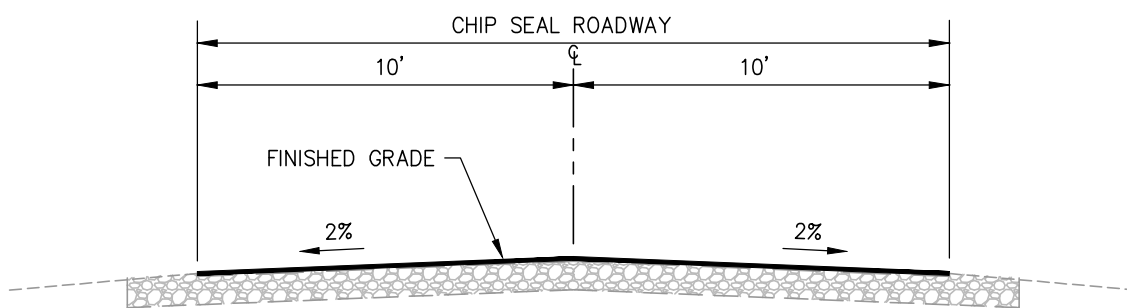

NOTE: CONDUCT ROADWAY SURFACE PREPARATION PER SPECIFICATIONS PRIOR TO CHIP SEALING.

CHIP SEAL DETAIL (1) NOT TO SCALE

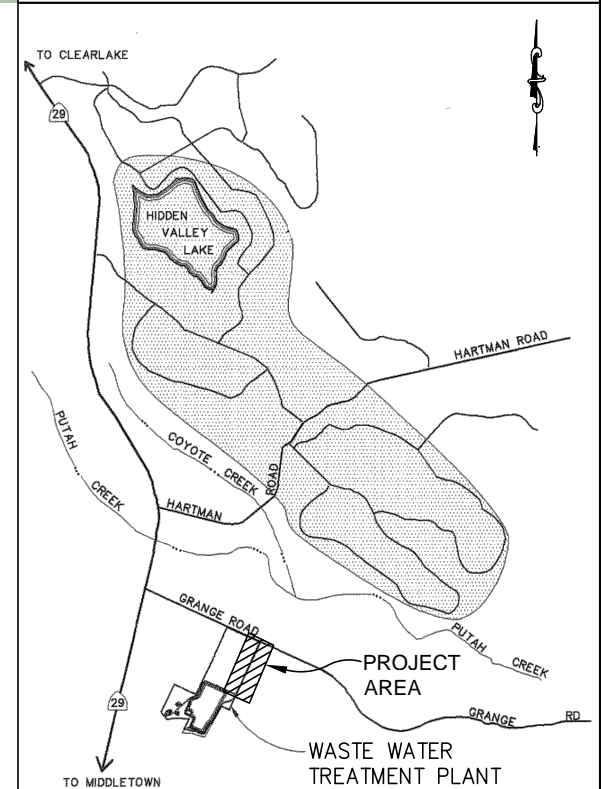

VICINITY MAP



Coastland Civil Engineering, Inc.
1400 Neotomas Avenue, Santa Rosa, CA 95405
707.571.8005 707.571.8037 Fax

Jennifer A. Melman
JENNIFER A. MELMAN

08/07/2020
DATE



HIDDEN VALLEY LAKE COMMUNITY SERVICES DISTRICT
WWTP ACCESS ROAD IMPROVEMENTS
AUGUST 2020

**ACTION OF
HIDDEN VALLEY LAKE COMMUNITY SERVICES DISTRICT**

DATE: August 18, 2020

AGENDA ITEM: Authorize Staff to solicit bids for the Meadow View Easement Sewer Replacement Project in support of CVRWQCB abatement requests originating from DR4301 and DR 4308

RECOMMENDATIONS: Authorize Staff to solicit bids for the Meadow View Easement Sewer Replacement Project in support of CVRWQCB abatement requests originating from DR4301 and DR4308

FINANCIAL IMPACT: \$133,852 (\$66,926)

FUND/AMT: 314

BACKGROUND:

Regulatory requirements for HVLCSO began in 2017 as a result of SSOs during disaster 4308. The Central Valley Regional Water Quality Control Board (Regional Waterboard) required HVLCSO to repair its sewer collection system to reduce Infiltration and Inflow (I&I). Annual capital expenditures of \$100,000.00 have been committed by HVLCSO since this mandate.

Due to staff's participation in the local Integrated Regional Water Management Group (IRWM), Westside SAC, grant funding for I & I abatement activities was awarded to the District in July. This program offers a 50% match to qualifying projects. The District has been awarded matching funds for I & I abatement activities up to a cap of \$375,000 (\$187,500 out of pocket). For this discrete activity of pipe bursting and replacement, the final financial responsibility of the District will be \$66,692.

The CCTV results of the Meadow View Easement is the most extensive repair that has been discovered since the mandate. Since the Design Contract was awarded to Coastland at the June 16, 2020 Board of Directors meeting, they have worked diligently together with staff to develop this detailed Bid Solicitation Package and Engineer's Cost Estimate. If it pleases the Board, an approval of this bid solicitation package will "line" the way towards a potential award of construction contract at the September 15, 2020 Board of Directors Meeting, which will in turn help facilitate a construction completion date of 11/5/20.

Modification to recommendation and/or other actions:

I, Penny Cuadras, Secretary to the Board, do hereby certify that the foregoing action was regularly introduced, passed, and adopted by said Board of Directors at a regular board meeting thereof held on August 18, 2020 by the following vote:

Ayes:

Noes:

Abstain:

Absent:

Attest: _____

Secretary to the Board

Hidden Valley Lake Community Services District
Engineer's Estimate of Construction Cost
Meadow View Easement Sewer Rehabilitation Project
August 2020

Item No.	Item Description	Estimated Quantity	Unit of Measure	Unit Cost	Item Total
1	Traffic Control	1	LS	\$ 2,500.00	\$ 2,500
2	Sheeting, Shoring, and Bracing	1	LS	\$ 6,000.00	\$ 6,000
3	Sewer Flow Control	1	LS	\$ 5,000.00	\$ 5,000
4	Replace 6-inch Sewer Main with HDPE by Pipe-Bursting	352	LF	\$ 200.00	\$ 70,400
5	Spot Repair 6-inch Sewer Main	2	LS	\$ 3,500.00	\$ 7,000
6	Reconnect Sewer Lateral on Private Property	4	EA	\$ 1,500.00	\$ 6,000
7	Reconnect or Replace District Mainline Cleanouts	2	EA	\$ 1,500.00	\$ 3,000
8	Mobilization	1	LS	\$ 5,000.00	\$ 5,000

Construction Cost \$ 104,900
Contingency (10%) \$ 10,490
Total Construction \$ 115,390

Construction Management and Inspection (16%) \$ 18,462
Total Cost \$ 133,852



HIDDEN VALLEY LAKE COMMUNITY SERVICES DISTRICT
HIDDEN VALLEY LAKE, CALIFORNIA

NOTICE TO CONTRACTORS

SPECIAL PROVISIONS, PROPOSAL AND CONTRACT

FOR

MEADOW VIEW EASEMENT SEWER REHABILITATION PROJECT

FOR USE IN CONNECTION WITH SPECIFIED
STANDARD SPECIFICATIONS AND STANDARD PLANS DATED 2018
OF THE CALIFORNIA DEPARTMENT OF TRANSPORTATION

AND

CURRENT GENERAL PREVAILING WAGE RATES AND
LABOR SURCHARGE AND EQUIPMENT RENTAL RATES
OF THE CALIFORNIA DEPARTMENT OF TRANSPORTATION

BID OPENING DATE:

September 10, 2020, at 11:30 a.m.

HIDDEN VALLEY LAKE COMMUNITY SERVICES DISTRICT
19400 Hartmann Rd
Hidden Valley Lake, CA 95467

NOTICE INVITING BIDS

NOTICE IS HEREBY GIVEN that sealed bids will be received by the Hidden Lake Valley Community Services, 19400 Hartmann Road, Hidden Valley Lake, California until the hour of **September 10, 2020, at 11:30 a.m.** at which time they will be publicly opened and read aloud in the conference room of the District office, for:

MEADOW VIEW EASEMENT SEWER REHABILITATION PROJECT

Complete bid packages, including project plans, technical specifications, bid forms and contract documents may be secured at the office of:

Coastland Civil Engineering
1400 Neotomas Ave.
Santa Rosa, California, 95405
Phone (707) 571-8005, fax (707) 571-8037

by emailing Ann Pomilia at pomilia@coastlandcivil.com. The bid documents are available electronically for free or by hard copy for the non-refundable cost of **\$30 per set**. **If mailing is desired an additional non-refundable cost of \$15.00 per set will be required.** Checks shall be made payable to "Coastland Civil Engineering". Any questions regarding the bid documents should be emailed to Jennifer Melman at Coastland Civil Engineering at melman@coastlandcivil.com.

In accordance with California Public Contract Code Section 3400, bidders may propose equals of products listed in the technical specifications or project plans by manufacturer name, brand or model number, unless the technical specifications or plans specify that the product is necessary to match others in use. Complete information for products proposed as equals must be submitted to the District for review at least 10 working days before the time specified for bid opening in accordance with the bidders instructions contained in the bid package.

In accordance with California Public Contract Code Section 20170, all bids must be presented under sealed cover and include one of the following forms of bidder's security: cash, cashier's check made payable to the District, certified check made payable to the District, or a bidder's bond. The amount of bidder's security provided must equal at least ten (10) percent of the total of the bid price for the base bid and the additive or deductive items listed in this notice. The successful bidder must submit to the District complete, executed copies of all required documents within ten (10) working days of receiving written notice of award of the project. Bidder's security of any successful bidder that fails to do so will be forfeited to the District. Such required documents include, but are not limited to, a payment or labor and materials bond in an amount of at least 100 percent of the amount payable by the terms of the project contract and that satisfies the requirements of California Civil Code Section 9554, and a performance bond in an amount of at least 100 percent of the amount payable by the terms of the contract. All project bonds must be executed by an admitted surety insurer in accordance with applicable law and acceptable to the District.

Pursuant to the provisions of Section 1770 et seq. of the California Labor Code the Director of Industrial Relations for the State of California has ascertained the current general prevailing rate of wages for employer purposes, in Lake County, State of California. Not less than the general prevailing rate of per diem wages for work of a similar character in Lake County and not less than the general prevailing rate of per diem wages for holiday work fixed as provided in the California Labor Code shall be paid to all workers engaged in performing the project.

Pursuant to the provisions of Section 1771.1 of the California Labor Code, a contractor or subcontractor shall not be qualified to bid on, be listed in a bid proposal, subject to the requirements of Section 4104 of the Public Contract Code, or engage in the performance of any contract for public work, as defined in Chapter 1 of Part 7 of Division 2 of the California Labor Code, unless currently registered and qualified to perform public work pursuant to Civil Code Section 1725.5. ***Please note: It is not a violation of Section 1771.1 for an unregistered contractor to submit a bid that is authorized by Section 7029.1 of the Business and Professions Code or by Section 10164 or 20103.5 of the Public Contract Code, provided the contractor is registered to perform public work pursuant to Section 1725.5 at the time the contract is awarded.*** Any bids submitted without proof that Bidder and any listed subcontractor(s) are currently registered and qualified to perform public work, pursuant to Labor Code Section 1725.5, shall not be accepted by the District.

In accordance with the California Labor Code Section 1773.2, copies of the applicable determinations are available at the District office and may be reviewed upon request.

In accordance with California Civil Code Section 1771.4, the project is subject to compliance monitoring and enforcement by the Department of Industrial Relations.

In accordance with California Public Contract Code Section 3300, a valid class A California contractor's license is required to bid on the project.

In accordance with California Public Contract Code Section 22300, except where prohibited by federal regulations or policies, the successful bidder may, on request and at its expense, substitute securities in lieu of amounts withheld by the District from progress payments to ensure performance under the contract in accordance with the contract documents.

The District reserves the right to postpone the date and time for the opening of proposals at any time prior to the date and time announced in the advertisement in accordance with applicable law.

The District reserves the right to reject any and all bids or to waive any defects or irregularity in bidding in accordance with applicable law. In accordance with California Public Contract Code Section 20103.8, if the District elects to award a contract for performance of the project, the contract will be awarded in accordance with California Public Contract Code Section 20162 and other applicable law to the responsible bidder submitting a responsive bid with the lowest total bid price for the total base bid without consideration of the bid price for any additive or deductive items. The lowest responsive bidder and any listed subcontractors will be checked to ensure that they are clear from the Federal Procurement and Non-Procurement Program List. All bids will remain valid for 90 days after the bid opening. Except as permitted by law and subject to all applicable remedies, including forfeiture of bidder's security, bidders may not withdraw their bid during the 90 day period after the bid opening.

By order of
The General Manager of the Hidden Valley Lake Community Services District
Lake County, California

TABLE OF CONTENTS

Instructions to Bidders.....	BB-1
Bidder's Check List.....	BB-11
Proposal and Schedule of Bid Prices.....	BB-12
Bid Bond.....	BB-14
Contractor License Information.....	BB-16
List of Subcontractors.....	BB-17
Workers Compensation Insurance Certification.....	BB-19
Non-Collusion Declaration.....	BB-20
Debarment Certification	BB-21
Debarment and Suspension Certification	BB-22
Public Contract Code Section 10285.1 Statement.....	BB-23
Public Contract Code Section 10162 Questionnaire	BB-24
Public Contract Code Section 10232 Statement.....	BB-25
Bidder's Signature Page	BB-26
Contract Check List.....	BB-28
Agreement.....	BB-29
Performance Bond	BB-34
Payment Bond.....	BB-36
Contract Change Order.....	BB-38
Maintenance Bond.....	BB-40
Escrow Agreement.....	BB-42

GENERAL PROVISIONS

<u>SECTION</u>	<u>TITLE</u>	
1.	Definitions	1
2.	Scope of Work.....	5
3.	Control of Work and Material and Changes in Work.....	7
4.	Trenching and Utilities and Project Facilities	20
5.	Prosecution and Progress of the Work.....	25
6.	Contractor Responsibilities.....	31
7.	Measurement and Payment.....	55
8.	Project Acceptance and Closeout	59
9.	Remedies and Disputes.....	61
10.	Special Provisions.....	75

PROJECT PLANS (2 sheets)

STANDARD DETAILS (EASTERN MUNICIPAL WATER DISTRICT)

1. SB-52: Sewer Cleanouts
2. SB-157: Pipe Zone Bedding For Sewer Pipe
3. SB-158: Trench Backfill For Sewer Pipe

INSTRUCTIONS TO BIDDERS

1. DEFINITIONS

- 1.1 Bid forms. The bid forms are the documents listed in the Bidder's Check List in the bid package Table of Contents as comprising the documents that must be submitted for each bid for it to be deemed complete.
- 1.2 Bid package. A complete bid package consists of the following documents: Notice Inviting Bids, Instructions to Bidders, Bidder's Check List, Proposal and Schedule of Bid Prices, Bid Bond, Contractor License Information, List of Proposed Subcontractors, Workers Compensation Insurance Certification, Non-collusion Declaration, Debarment Certification, Debarment and Suspension Certification, Public Contract Code Section 10285.1, Public Contract Code Section 10162 Questionnaire, Public Contract Code Section 10232 Statement, Bidder's Questionnaire, if any, Bidder's Signature Page, Contract Check List, Contract, Performance Bond, Payment Bond, Contract Change Order, Maintenance Bond, Escrow for Security Deposit Agreement, General Provisions, Special Provisions, and the Project Plans.
- 1.3 Contract documents. The contract documents are all of the documents incorporated into the final Project contract as listed in the contract.
- 1.4 Project. The Project is the **MEADOW VIEW EASEMENT SEWER REHABILITATION PROJECT** described in the bid package.
- 1.5 Project Plans. The Project Plans are the primarily graphic detailed requirements concerning the Project contained in the bid package.
- 1.6 Technical Specifications. The Technical Specifications provide detailed requirements concerning the Project and are contained in Special Provisions in the bid package.

2. BIDDER'S REPRESENTATIONS

Each bidder by submitting a bid represents that:

- 2.1 The bidder has read and understands the bid package and the bid is in accordance with all of the requirements of the bid package and applicable law.
- 2.2 Neither the bidder nor any subcontractor included on the list of proposed subcontractors submitted with the bid is ineligible to perform work on public works projects pursuant to California Labor Code Sections 1777.1 or 1777.7.
- 2.3 The bidder understands that quantities of unit price items may vary from the estimates provided in the technical specifications.
- 2.4 Representatives of the bidder have visited the Project site and have familiarized themselves with the conditions under which the Project work is to be performed so as to ensure that the Project work may be performed for the amount bid.

- 2.5 The bidder has informed the District in writing no later than five (5) working days prior to the time specified for bid opening of any apparent conflicts, errors, or ambiguities contained in the bid package or between the contents of the bid package and the Project site.

3. EXAMINATION OF PLANS, SPECIFICATIONS, CONTRACT, AND WORK SITE

- 3-1 The bidder shall examine carefully the work site, the Project Plans and Technical Specifications, and the entire Bid Package. The submission of a bid shall be conclusive evidence that the bidder has investigated and is satisfied as to the general and local conditions to be encountered, as to the character, quality and scope of work to be performed, the quantities of materials to be furnished and as to the requirements of the Contract Documents.
- 3-2 The submission of a bid shall also be conclusive evidence that the bidder is satisfied as to the character, quality and quantity of surface and subsurface materials or obstacles to be encountered insofar as this information was reasonably ascertainable from an inspection of the site and the records of exploratory work done by the District as shown in the bid documents, as well as from the Project Plans and Technical Specifications.
- 3-3 Where the District has made investigations of work site conditions including subsurface conditions in areas where Work is to be performed, or in other areas, that may constitute possible local material sources, bidders may, upon request, inspect the records of the District as to those investigations.
- 3-4 Where there has been prior construction by the District or other public agencies within the project limits, records of the prior construction that are currently in the possession of the District and that have been used by, or are known to, the designers and administrators of the project will be made available for inspection by bidders, upon request, subject to this Section 3. Such records may include, but are not limited to, as-built drawings, design calculations, foundation and site studies, project reports and other data assembled in connection with the investigation, design, construction and maintenance of the prior projects.
- 3-5 Inspection of the records of investigations and project records in the possession of the District may be made at the District Office.
- 3-6 When a log of test borings or other record of geotechnical data obtained by the District's investigation of surface and subsurface conditions is included with the Project Plans, it is furnished for the bidders' information and its use shall be subject to this Section 3.
- 3-7 In some instances, information considered by the District to be of possible interest to bidders has been compiled as "Materials Information." The use of the "Materials Information" shall be subject to the conditions and limitations set forth in this Section 3.
- 3-8 When cross sections are not included with the Project Plans, but are available, bidders may inspect the cross sections and obtain copies for their use, at their expense.
- 3-9 When cross sections are included with the Project Plans, it is expressly understood and agreed that the cross sections do not constitute part of the Agreement, do not necessarily represent actual site conditions or show location, character, dimensions and details of Work to be performed, and

are included in the Project Plans only for the convenience of bidders and their use is subject to the conditions and limitations set forth in this Section 3.

- 3-10 When contour maps were used in the design of the project, bidders may inspect those maps, and if available, they may obtain copies for their use.
- 3-11 The availability or use of information described in this Section 3 is not to be construed in any way as a waiver of any of the provisions in this Section 3 and bidders are cautioned to make independent investigations and examinations as they deem necessary to be satisfied as to conditions to be encountered in the performance of the Work and, with respect to possible local material sources, the quality and quantity of material available from the property and the type and extent of processing that may be required in order to produce material conforming to the requirements of the Technical Specifications.
- 3-12 The District assumes no responsibility for conclusions or interpretations made by a bidder based on the information or data made available by the District. The District does not assume responsibility for representation made by its officers or agents before the execution of the Agreement concerning surface or subsurface conditions, unless that representation is expressly stated in the Contract Documents.
- 3-13 No conclusions or interpretations made by a bidder from the information and data made available by the District will relieve a bidder from properly fulfilling the terms of the Agreement.

4. PRE-BID COMMUNICATION AND INTERPRETATION OF THE BID PACKAGE

- 4.1 Any bidder that discovers any apparent conflicts, errors, or ambiguities contained in the bid package or between the contents of the bid package and the Project site, or that has questions or requires clarification concerning the bid package or its intent must inform the District in writing as soon as reasonably possible, but no later than five (5) working days before the date specified for bid opening. Such notice to the District must be sent to the address specified in the Notice Inviting Bids for questions concerning the bid package or sent via electronic mail to Jennifer Melman at melman@coastlandcivil.com. Questions received less than five (5) working days before the time specified for opening bids may not be answered.
- 4.2 Any interpretation, correction or change of the bid package prior to bid opening will be made by addendum signed by an authorized representative of the District and transmitted to all bid package recipients. No other interpretation or information concerning the bid package issued prior to the date specified for opening bids will be binding. All addenda signed by an authorized representative of the District and issued prior to the time and date specified for opening bids will form a part of the contract documents and must be acknowledged on the bid forms. Any changes, exceptions or conditions concerning the Project and/or the bid package submitted by any bidder as part of a bid may render that bid non-responsive.

5. PRE-BID ACCESS TO THE PROJECT SITE

- 5.1 Prior to submitting a bid, it will be the sole responsibility of each bidder to conduct any additional examination, investigation, exploration, testing, study or other inquiry and to obtain any additional information pertaining to the physical conditions (including surface, subsurface, and underground utilities) at or near the Project site that may affect the cost, progress, or performance

of the Project, and that the bidder deems are necessary to prepare its bid for performance of the Project in accordance with the bid package and contract documents. Bidders seeking any such additional examination or other inquiries or information concerning the Project will do so at the bidder's sole expense.

- 5.2 Bidders seeking to conduct any additional examination or other inquiry at the Project site must request site access from the District at least two (2) working days in advance. The location of any excavation, boring or other invasive testing will be subject to approval on behalf of the District and any other agencies with jurisdiction over such testing. Bidders may not conduct tests at the Project site prior to obtaining District approval. The District may require bidders to execute an access agreement prior to approving testing at the Project site. Once approved testing is complete, Bidders must fill all trenches or holes, restore all pavement to match existing structural section, and otherwise clean up and restore the test site to its pre-test condition.

6. BIDDING PROCEDURE

- 6.1 Bids must be delivered to the Hidden Lake Valley Community Services, 19400 Hartmann Road, Hidden Valley Lake, California, no later than the time and date specified in the Notice Inviting Bids. Bids will be opened and read publicly at that time. Bids that are submitted late according to the official time kept by the District will be returned unopened. Telephones for use by bidders are not available at the District offices.
- 6.2 In accordance with California Public Contract Code Section 20170, Bids must be presented under sealed cover. Bids must be submitted using the bid forms furnished with the bid package. Bids must include all documents listed in the Bidder's Check List completed in accordance with the bid package. Bids must bear the bidder's legal name and be signed by a representative authorized to bind the bidder. Bids must be typed or written in ink. Corrections may be made if initialed by the individual signing the bid. No oral or telegraphic modifications of bids, including facsimile modifications, will be considered. Bids that are incomplete or that are not presented on the bid forms furnished with the bid package may be deemed non-responsive.
- 6.3 Each bid must give the full business address of the bidder. Bids of partnerships must furnish the full name of all partners and must be signed in the partnership name by one of the members of the partnership, or by an authorized representative, followed by the printed name and title of the person signing. Bids of corporations must be signed with the legal name of the corporation, followed by the name of the state of incorporation and by the signature and designation of the president, secretary or other person authorized to bind the corporation. The name of each person signing shall also be typed or printed below the signature. Upon request of the District, bidders will furnish satisfactory evidence of the authority of the person signing the bid. Bids of joint ventures must include a certified copy of the legal agreement constituting the joint venture.
- 6.4 No person, firm, corporation, partnership or legal joint venture may submit more than one bid for the Project. However, a person, firm, corporation, partnership or legal joint venture that has submitted a subcontract proposal to a bidder, or that has quoted prices on materials to a bidder may submit a subcontract proposal, quote prices to other bidders and submit its own bid.
- 6.5 In accordance with California Public Contract Code Section 20170, all bids must include one of the forms of bidder's security specified in the Notice Inviting Bids in an amount of at least ten (10) per cent of the total of the bid prices for the base bid and those additive or deductive items specifically identified in the Notice Inviting Bids for the purpose of determining the lowest price

bid. Bidders that elect to provide bidder's security in the form of a bid bond must execute a bid bond using the form provided in the bid forms. The bidder's security is tendered as a guarantee that the successful bidder, if awarded the Project contract, will execute and submit to the District all required bonds, certificates of insurance, completed contract forms and other documents listed in the Contract Check List and enter into a contract with the District within ten (10) working days of receipt of the notice of award. The bidder's security of any successful bidder that fails to do so will be forfeited to the District. All bidders' security not forfeited to the District will be returned once a successful bidder provides all required documents and enters a contract with the District in accordance with all applicable bid package requirements. Forfeiture of the bidder's security to the District will not waive or otherwise limit any other remedy available to the District under applicable law.

- 6.6 In accordance with California Business and Professions Code Section 7028.15, Public Contract Code Section 20103.5, and as specified in the Notice Inviting Bids, all Project work must be performed by properly licensed contractors and subcontractors with active licenses in good standing as of the date and time specified for bid opening, or, if the Project involves federal funds, no later than the time the Project contract is awarded. Bidders must verify their Contractor's License number and license expiration date on the proposal cover page under penalty of perjury. Bids that do not satisfy applicable licensing requirements will be considered non-responsive and rejected and may subject the bidder to criminal and/or civil penalties.
- 6.7 In accordance with California Civil Code Section 1771.1, the District shall accept bids only from bidders which (along with all listed subcontractors) are currently registered and qualified to perform public work pursuant to Civil Code Section 1725.5. The District may, however, accept a non-complying bid provided that bidder (and all listed subcontractors) are registered and qualified at the time of award.
- 6.8 If the bid forms include a bidder's questionnaire, all bids must include a completed bidder's questionnaire on the forms provided. By submitting a bid, bidders authorize District representatives to verify any and all information provided on the bidder's questionnaire and agree to indemnify, defend and hold harmless the District and its officials, officers, employees, agents and volunteers to full the extent permitted by law from and against any claims, liability or causes of action, including, without limitation, legal fees and costs, arising out of verification of the information provided on the bidder's questionnaire, and/or arising out of use of information provided in the bidder's questionnaire to determine, in accordance with applicable law, the qualification of the bidder for performing the Project.
- 6.9 Bids may be withdrawn prior to the time set for bid opening by a written request signed by an authorized representative of the bidder filed with the District. The bid security submitted with bids so withdrawn will be returned to the bidder. Bidders that have withdrawn their bid in accordance with this provision may submit a new bid prior to the time set for bid opening in accordance with all applicable bid package requirements. Bids may not be withdrawn during the ninety day period after the time set for bid opening except as permitted by law pursuant to California Public Contract Code Section 5100 and following. Any other bid withdrawal will result in forfeiture of the bidder's bid security to the District.

7. BID PROTESTS

Any protest of the proposed Project award must be submitted in writing to the District no later than 5:00 PM on the third business day following the date of the bid opening.

- 7.1 The protest must contain a complete statement of the basis for the protest.
- 7.2 The protest must state the facts and refer to the specific portion of the document or the specific statute that forms the basis for the protest. The protest must include the name, address, and telephone number of the person representing the protesting party.
- 7.3 The party filing the protest must concurrently transmit a copy of the protest to the proposed awardee.
- 7.4 The party filing the protest must have actually submitted a bid for the Project. A subcontractor of a party filing a bid for the Project may not submit a bid protest. A party may not rely on the bid protest submitted by another bidder but must timely pursue its own protest.
- 7.5 The procedure and time limits set forth in these Instructions to Bidders are mandatory and are the bidders' sole and exclusive remedy in the event of a bid protest. Any bidder's failure to fully comply with these procedures shall constitute a waiver of any right to further pursue a bid protest, including filing of a challenge of the award pursuant to the California Public Contract Code, filing of a claim pursuant to the California Government Code, or filing of any other legal proceedings.
- 7.6 The District shall review all timely protests prior to award of the Project. The District shall not be required to hold an administrative hearing to consider any protests but may do so at its option. At the time of the District's Board of Directors consideration of the Project award, the Board of Directors shall also consider the merits of any timely protests. The Board of Directors may either reject the protest and award to the lowest responsible bidder or accept the protest and award the bid to the next lowest responsible bidder. Nothing in this section shall be construed as a waiver of the Board of Directors right to reject all bids.

8. AWARD

- 8.1 In accordance with applicable law, the District reserves the right to reject any or all bids and to waive any informality in any bid. The District reserves the right to accept any portion of any bid, unless the bid package expressly provides that the award will be made as a whole. If the District elects to award a contract for performance of the Project, the contract will be awarded in accordance with California Public Contract Code Section 20162 and other applicable law to the responsible bidder submitting a responsive bid with the lowest total bid price for the base bid without consideration of the bid price for any additive or deductive alternate items. In accordance with the contract documents and other applicable law, the District may add or deduct items of work from the Project after the lowest responsible bidder is determined.
- 8.2 The successful bidder must submit to the District complete, executed copies of all documents specified in the Contract Checklist within ten (10) working days of receiving written notice of award of the Project. Bidder's security of any successful bidder that fails to do so will be forfeited to the District.
- 8.3 The successful bidder and any subcontractors and others engaged in performance of the Project must have valid local business license(s), as applicable, before commencing work on the Project.

8.4 Upon verifying that the successful bidder has provided complete, executed copies of all documents specified in the Contract Checklist an authorized District representative will execute the Project contract, and the District will issue to the successful bidder a notice to proceed specifying the Project commencement date. The number of days within which the Project must be complete begins to run on the Project commencement date.

9. PRICING

9.1 If an inconsistency exists between the amount listed for a unit price in a bid and the total listed for that bid item (e.g., if the total listed for a bid item does not equal the unit price listed in the bid multiplied by the quantity listed), subject to applicable law, the unit price will be deemed to accurately reflect the bidder's intent concerning the bid item and the intended total for the bid item will be deemed to be the unit price as listed in the bid multiplied by the quantity listed.

9.2 If the Project bid price is a lump sum total made up of smaller individual bid item prices and an inconsistency exists between the lump sum total bid price and any individual bid item price, subject to applicable law, the individual bid item prices as listed in the bid will be deemed to accurately reflect the bidder's intended bid for the Project and the intended lump sum total bid for the Project will be deemed to be the sum of the individual bid item prices as listed in the bid, even if that sum is different from the amount actually listed as the lump sum total bid for the Project.

9.3 Any federal, state, or local tax payable on articles to be furnished for the Project shall be included in the lump sum total bid price and paid by the Contractor under the contract.

10. QUANTITIES

10.1 Quantities, including but not limited to, material or labor quantities, that are provided in the bid package concerning the Project are estimates only and are provided solely as a general indication of the Project scope. The District does not warrant that such quantity estimates provided in the bid package represent the actual quantities required to perform the Project in accordance with the contract documents. Such quantity estimates do not bind the District, and bidders should not rely on them in preparing their bids. Each bidder is solely responsible for determining the quantities on which to base their bids in light of information contained in the bid package, bidder investigation and analysis of the Project and the Project site, and any other analysis or expertise of the bidder concerning the Project.

10.2 The District may amend, decrease or increase the Project work in accordance with the bidding package and the contract documents. If the District amends, decreases or increases the Project work prior to award of the Project each bidder will be solely responsible for determining the revised quantities, if any, on which to base their bid in light of information contained in the bid package and any amendments or addenda to the bid package, bidder investigation and analysis of the Project as amended, decreased or increased, the Project site, and any other analysis or expertise of the bidder concerning the Project.

11. SUBSTITUTION OF "OR EQUAL" ITEMS

11.1 In accordance with California Public Contract Code Section 3400, where the Technical Specifications or Project Plans list products by manufacturer's name, brand or model number such information indicates the quality and utility of the items desired and does not restrict

bidders to that manufacturer's name, brand or model number, unless the Technical Specifications or Project plans specify that the listed product is necessary to match others in use on a particular public improvement either completed or in the course of completion. Except where the Technical Specifications indicate that a particular brand product is necessary to match others in use, when a manufacturer's name, brand or model number is listed, it shall be construed to be followed by the words "or equal" whether or not those words in fact follow the manufacturer's name, brand name or model number listed in the Technical Specifications or Project Plans. Unless the Technical Specifications or Project Plans indicate that a particular brand product is necessary to match others in use, bidders may propose equals of products listed by manufacturer name, brand name or model number.

- 11.2 Complete information for products proposed as equals must be submitted to the District for review by at least ten (10) working days before the time specified for opening bids. To be considered, proposals concerning products proposed as equals must include sufficient information to permit the District to determine whether the products proposed as equals will satisfy the same performance requirements as products listed by manufacturer's name, brand or model number. Such performance requirements may include, but are not limited to, size, strength, function, appearance, ease of maintenance and repair, and useful life requirements. Proposals concerning products proposed as equals that are submitted later than ten (10) working days before the time specified for opening bids will not be considered. Failure to bid products specified by manufacturer name, brand name or model number where the Technical Specifications or Project Plans specify that a particular product is necessary to match others in use, or where no proposal concerning products proposed as equals has been submitted in accordance with this provision may render a bid non-responsive.

12. SUBCONTRACTING

- 12.1 Bids must be in accordance with the requirements of the Subletting and Subcontracting Fair Practices, Act, California Public Contract Code Section 4100 and following. Bids must include a completed list of proposed subcontractors on the form included in the bid package. In accordance with California Public Contract Code Section 4104, completed lists of proposed subcontractors must include the name, business location, the portion (type or trade), and dollar amount of the Project work to be subcontracted for each subcontractor that will perform a portion of the Project work (including special fabrication and installation of a portion of the work) valued in excess of one half of one percent of the total Project bid price. If the Project work includes construction of streets or highways, the completed list of proposed subcontractors must include the subcontractor name, business location, type of work and dollar amount to be subcontracted for each subcontractor that will perform a portion of the Project work (including special fabrication and installation of a portion of the work) valued in excess of one half of one percent of the total Project bid price, or ten thousand dollars (\$10,000), whichever is greater.
- 12.2 In accordance with California Public Contract Code Section 4106, for any portion of the Project work with a value of more than one half of one percent of the total Project bid price for which no subcontractor is listed, or for which more than one subcontractor is listed, bidders certify by submitting their bids that they are qualified to perform that portion of the Project work and that they will perform that portion of the Project work with their own forces. Bidders may not substitute another subcontractor for a subcontractor listed in their bid except as permitted by the District in accordance with Section 4107 and following of the California Public Contract Code.

13. ASSIGNMENT

Bidders may not assign, sublet, sell, transfer, or otherwise dispose of their bid or any right, title or interest in their bid, or their obligations under their bid, without the written consent of an authorized representative of the District. Any purported assignment, subletting, sale, transfer or other disposition of a bid or any interest in a bid, or of any obligations under a bid without such written consent will be void and of no effect.

14. BONDS

- 14.1 The successful bidder must submit to the District a performance bond within ten (10) working days of receiving written notice of award. If the Project involves expenditures in excess of twenty-five thousand dollars (\$25,000), the successful bidder must submit to the District a payment or labor and materials bond within ten (10) working days of receiving written notice of award. Prior to issuance of the final Project payment, the successful bidder must submit a maintenance bond. All bonds must be executed by corporate sureties who are admitted surety insurers in the State of California in accordance with applicable law and acceptable to the District. Individual sureties will not be accepted. All Project bonds must be executed using the forms provided in the bid package.
- 14.2 In accordance with California Civil Code Section 9554, the payment or labor and materials bond must be in the amount of one hundred percent of the total amount payable by the terms of the Project contract and guarantee payment to persons listed in California Civil Code Section 9100 for work performed and for charges for materials, supplies, and equipment provided under the Project contract (including amounts due under or subject to the Unemployment Insurance Code).
- 14.3 The performance bond must be in the amount of one hundred percent of the amount payable by the terms of the Project contract to guarantee the faithful performance of the Project work.
- 14.4 The maintenance bond must be in the amount of twenty percent of the final Project contract amount and guaranty the Project work against defects in materials, equipment, workmanship, or needed repair for one year from the District's acceptance of the Project work.

15. LABOR LAWS

- 15.1 Bidders must comply with applicable provisions of the California Labor Code.
- 15.2 In accordance with California Labor Code Section 1861, bids must include a workers compensation insurance certification on the form included in the bid package.
- 15.3 In accordance with California Labor Code Section 1771, not less than the general prevailing rate of per diem wages for work of a similar character in the locality in which the Project is to be performed, and not less than the general prevailing rate of per diem wages for holiday and overtime work fixed as provided in the California Labor Code shall be paid to all workers engaged in performing the Project.

- 15.4 In accordance with California Labor Code Section 1770 and following, the Director of Industrial Relations has determined the general prevailing wage per diem rates for work in the locality in which the Project is to be performed. In accordance with California Labor Code Section 1773, the District has obtained the general prevailing rate of per diem wages and the general rate for holiday and overtime work in the locality in which the Project is to be performed for each craft, classification or type of worker needed to perform the Project. In accordance with California Labor Code Section 1773.2, copies of the prevailing rate of per diem wages are on file at the District office and will be made available on request.
- 15.5 In accordance with California Labor Code Section 1777.1, contractors and subcontractors that are found guilty of willfully violating Chapter 1 of Part 7 of Division 2 of the Labor Code (except for Section 1777.5), or that are found guilty of such violations with intent to defraud, and entities in which such contractors or subcontractors have any interest, may be ineligible to bid on, be awarded, or perform Project work as a subcontractor.

BIDDER'S CHECK LIST

Did You:

- _____ Submit equal product proposals, if any, in accordance with the instructions to bidders included in the bid package at least 10 working days before the time specified for opening bids?

- _____ Include with your bid properly completed, accurate copies of the following documents in the following order using the forms included in the bid package:
 - _____ Bidder's check list?
 - _____ Proposal and Schedule of Bid Prices that state the bid as intended?
 - _____ If any, Copies of each addendum issued signed and dated on behalf of the bidder?
 - _____ Executed bid bond?
 - _____ Contractor license information?
 - _____ Contractor DIR registration information?
 - _____ List of subcontractors, including DIR registration information?
 - _____ Workers compensation insurance certification?
 - _____ Signed and notarized Non-Collusion Declaration?
 - _____ Debarment certification?
 - _____ Bidder's questionnaire, if any?
 - _____ Executed bidder's signature page?

- _____ Arrange to have the sealed bid delivered to the District offices at 19400 Hartmann Road, Hidden Valley Lake, CA 95467 on or before the time specified for bid opening in the notice inviting bids?

PROPOSAL

For: Construction of the MEADOW VIEW EASEMENT SEWER REHABILITATION PROJECT

For the Hidden Valley Lake Community Services District, Lake County, California.

TO THE BOARD OF DIRECTORS
OF THE HIDDEN VALLEY LAKE COMMUNITY SERVICES DISTRICT

The undersigned, as bidder, declares that it has carefully examined the work, the annexed proposed form of contract, and agrees that if this Proposal is accepted to contract with the Hidden Valley Lake Community Services District, under the form of contract annexed hereto, to provide all the necessary tools, apparatus, and other means of accomplishing the work as specified in the contract in the manner and time herein prescribed, and in accordance with the requirements of the District as therein set forth, and to take in full payment thereof the following prices of the work to be done completely performed to the satisfaction of the Hidden Valley Lake Community Services District, to-wit:

Contractor's Bid Proposal

Item No.	Item Description	Estimated Quantity	Unit of Measure	Unit Cost (in figures)	Total Cost (in figures)
1	Temporary Traffic Control	1	L.S.	\$	\$
2	Sheeting, Shoring, and Bracing	1	L.S.	\$	\$
3	Sewer Flow Control	1	L.S.	\$	\$
4	Replace 6-inch Sewer Main with HDPE by Pipe-Bursting	352	L.F.	\$	\$
5	Spot Repair 6-inch Sewer Main	2	EA	\$	\$
6	Reconnect Sewer Lateral on Private Property	4	EA	\$	\$
7	Reconnect or Replace District Mainline Cleanouts	2	EA	\$	\$
8	Mobilization and Demobilization	1	L.S.	\$	\$

Total Bid: \$ _____

Dollars

Written Amount

The undersigned further agrees to deliver and to complete the work within **15 working days**, from the date of issuance, by the District, of instructions to proceed with the work, and within 10 days of the date of mailing of the notice of award, to enter into and execute and provide to the District the necessary contract with the necessary bonds and other required documents, and in case of default in executing the necessary contract within the time fixed by the Instructions to Bidders, the bidder's security accompanying this bid shall become the property of and be forfeited to the District.

Prime Contractor _____

License # _____ Expiration Date _____

DIR Registration # _____ Expiration Date _____

Contractor's License number and expiration date are herein stated under penalty of perjury.

By: _____ Title: _____

Dated this _____ day of _____, 2020

(Corporate Seal)

Corporate Signature

Address: _____

Phone No.: _____

President's signature _____

Secretary's signature _____

Corporation organized under the laws of the State of _____

Partnership Name: _____

Address: _____

Names of Co-Partners and Addresses: _____

Names of Individuals and Addresses: _____

NOTE: Sign in proper space above.

HIDDEN VALLEY LAKE COMMUNITY SERVICES DISTRICT

19400 Hartman Road
Hidden Valley Lake, California 95467

BID BOND

(NOTE: Bidders must use this form, use of any other bond form may render a bid non-responsive)

KNOW ALL MEN BY THESE PRESENTS:

That we, as PRINCIPAL, and _____, a (sole proprietorship/corporation/partnership/joint venture) organized and existing under and by virtue of the laws of the State of _____ and an admitted surety insurer authorized to do business in the State of California, as SURETY, are held and firmly bound unto the Hidden Valley Lake Community Services District, as OBLIGEE, in a penal sum equal to ten-percent (10%) the total bid price including the base bid and alternates specified in the proposal of the PRINCIPAL, to the OBLIGEE for the work described below, which penal sum is _____ (\$ _____) lawful money of the United States of America, for the payment of which sum well and truly to be made, we, and each of us, bind ourselves, our heirs, executors, administrators, successors, and assigns, jointly and severally, firmly by these presents.

THE CONDITION OF THIS OBLIGATION IS SUCH that whereas the PRINCIPAL has submitted the accompanying proposal dated _____, _____ to the OBLIGEE, for the **MEADOW VIEW EASEMENT SEWER REHABILITATION PROJECT** (designated as the "Project") which proposal is hereby made a part hereof;

NOW THEREFORE, if the PRINCIPAL shall not withdraw said proposal within the ninety (90) day period following the opening of bids, and if the PRINCIPAL receives written notice that the Project is awarded to the PRINCIPAL and shall, within ten (10) calendar days of receiving such notice: enter into a written contract with the OBLIGEE in the form prescribed in the bid package issued by the OBLIGEE concerning the Project; and give insurance and bond with good and sufficient sureties guaranteeing the faithful performance and proper fulfillment of such contract and guaranteeing payment for labor and materials used for performance of the contract as required by law; and file with the OBLIGEE all required documents and do all other thing required in accordance with the bid package issued by the OBLIGEE concerning the Project for the contract between the PRINCIPAL and the OBLIGEE to become effective and for work to commence in accordance with the bid package issued by the OBLIGEE concerning the Project , or, in the event of withdrawal of the accompanying proposal within the ninety (90) day period following the opening of bids; or failure by the PRINCIPAL to enter into such contract with the OBLIGEE or to give the OBLIGEE such bonds or to file any other documents or to do any other things required in the bid package issued by the OBLIGEE for the Project, if the PRINCIPAL shall pay the OBLIGEE the difference between the total bid price in the accompanying proposal and the amount for which the OBLIGEE may procure the required performance, if the latter amount be in excess of the former, together with all costs incurred by the OBLIGEE in again attempting to let the Project, and if the said PRINCIPAL shall fully reimburse and save harmless the OBLIGEE from any damage sustained by the OBLIGEE through failure of the PRINCIPAL to enter into the written contract or to file the required performance or labor and material bonds, or to file any other required documents or to do any other things required for the contract between the PRINCIPAL and the OBLIGEE to become effective and the work to commence in accordance with the bid package issued by the OBLIGEE

concerning the Project, then this obligation shall be null and void; otherwise, it shall be and remain in full force and effect.

SURETY, for value received, hereby stipulates and agrees that no change, extension of time, alteration or addition to the terms of the bid or contract documents for the Project, or to the specifications included in the same, or to the work to be performed thereunder, or to the notice inviting bids, or to any other documents concerning the Project, shall in anywise affect SURETY's obligation under this bond, and SURETY hereby waives notice of any such change, extension of time, alteration or addition to such bid or contract documents.

In the event suit is brought upon this bond by the OBLIGEE and judgment is recovered, the SURETY shall pay all costs incurred by the OBLIGEE in such suit, including a reasonable attorney's fee to be fixed by the Court.

IN WITNESS WHEREOF, the above-bound parties have executed this instrument under their several seals this _____ day of _____, _____, the name and corporate seals of each corporate party being hereto affixed and these presents duly signed by their undersigned representatives, pursuant to authority of their governing bodies.

(Corporate Seal) PRINCIPAL _____
By _____

(Acknowledgement) Title _____
SURETY _____
(Corporate Seal)

By _____
(Attorney-in-fact)

(Acknowledgement) Title _____

(NOTE TO SURETY COMPANY: A certified copy of unrevoked resolution of authority for the attorney-in-fact must be submitted with and attached to the executed bid bond.)

CONTRACTOR LICENSE INFORMATION

The bidder acknowledges that a license is required for performance of Hidden Valley Lake Community Services District **MEADOW VIEW EASEMENT SEWER REHABILITATION PROJECT**.

The bidder holds the following California Contractors License(s):

- 1. License No. _____, Class _____, Expiration Date _____
- 2. License No. _____, Class _____, Expiration Date _____
- 3. License No. _____, Class _____, Expiration Date _____
- 4. License No. _____, Class _____, Expiration Date _____
- 5. License No. _____, Class _____, Expiration Date _____
- 6. License No. _____, Class _____, Expiration Date _____
- 7. License No. _____, Class _____, Expiration Date _____
- 8. License No. _____, Class _____, Expiration Date _____
- 9. License No. _____, Class _____, Expiration Date _____
- 10. License No. _____, Class _____, Expiration Date _____

Bidder's Taxpayer Identification No. _____

LIST OF SUBCONTRACTORS

In accordance with the requirements of the Subletting and Subcontracting Fair Practices Act, California Public Contract Code Section 4100 and following, listed below are the name, business location, and the portion (type or trade) of the Project work to be subcontracted to each subcontractor that will perform a portion of the Project work (including special fabrication and installation of a portion of the work) valued in excess of one half of one percent of the total bid price. If the Project work includes construction of streets or highways, listed below are the name, business location, and the portion (type or trade) of the Project Work to be subcontracted to each subcontractor that will perform a portion of the Project work (including special fabrication and installation of a portion of the work) valued in excess of one half of one percent of the total Project bid price, or ten thousand dollars, whichever is greater. Also listed below are the proposed subcontract dollar amount and current California Contractor's License Number(s) for each proposed subcontractor. Bids that fail to include complete proposed subcontractor information in accordance with this form and Public Contract Code Section 4100 and following may be deemed non-responsive.

In accordance with California Public Contract Code Section 4106, for any portion of the Project work with a value of more than one half of one percent of the total bid price for which no subcontractor is listed, or for which more than one subcontractor is listed, the bidder certifies by submission of its bid that the bidder is qualified to perform that portion of the Project work and that the bidder will perform that portion of the Project work with its own forces. The penalties listed in California Public Contract Code Section 4111 will apply to any substitution of another subcontractor for a subcontractor listed below except as permitted by the District in accordance with Section 4107 and following of the California Public Contract Code.

1. Subcontractor Name _____
Business Location _____
Trade _____
Subcontract Amount _____
Current Contractor's License No.(s) _____
Current DIR Registration No. _____
2. Subcontractor Name _____
Business Location _____
Trade _____
Subcontract Amount _____
Current Contractor's License No.(s) _____
Current DIR Registration No. _____
3. Subcontractor Name _____
Business Location _____
Trade _____
Subcontract Amount _____
Current Contractor's License No.(s) _____
Current DIR Registration No. _____
4. Subcontractor Name _____
Business Location _____
Trade _____
Subcontract Amount _____
Current Contractor's License No.(s) _____
Current DIR Registration No. _____

5. Subcontractor Name _____
 Business Location _____
 Trade _____
 Subcontract Amount _____
 Current Contractor's License No.(s) _____
 Current DIR Registration No. _____
6. Subcontractor Name _____
 Business Location _____
 Trade _____
 Subcontract Amount _____
 Current Contractor's License No.(s) _____
 Current DIR Registration No. _____
7. Subcontractor Name _____
 Business Location _____
 Trade _____
 Subcontract Amount _____
 Current Contractor's License No.(s) _____
 Current DIR Registration No. _____
8. Subcontractor Name _____
 Business Location _____
 Trade _____
 Subcontract Amount _____
 Current Contractor's License No.(s) _____
 Current DIR Registration No. _____
9. Subcontractor Name _____
 Business Location _____
 Trade _____
 Subcontract Amount _____
 Current Contractor's License No.(s) _____
 Current DIR Registration No. _____
10. Subcontractor Name _____
 Business Location _____
 Trade _____
 Subcontract Amount _____
 Current Contractor's License No.(s) _____
 Current DIR Registration No. _____
11. Subcontractor Name _____
 Business Location _____
 Trade _____
 Subcontract Amount _____
 Current Contractor's License No.(s) _____
 Current DIR Registration No. _____
12. Subcontractor Name _____
 Business Location _____
 Trade _____
 Subcontract Amount _____
 Current Contractor's License No.(s) _____
 Current DIR Registration No. _____

WORKERS COMPENSATION INSURANCE CERTIFICATION

By submitting its bid the bidder certifies as follows:

I am aware of the provisions of California Labor Code Section 3700, which require every employer to be insured against liability for workmen's compensation or to undertake self-insurance in accordance with the provisions of the Labor Code, and I will comply with such provisions before commencing performance of the work of this Contract.

**NON-COLLUSION DECLARATION
TO BE EXECUTED BY BIDDER
AND SUBMITTED WITH BID**

The undersigned declares:

I am the _____ of _____, the party making the foregoing bid. The bid is not made in the interest of, or on behalf of, any undisclosed person, partnership, company, association, organization, or corporation. The bid is genuine and not collusive or sham. The bidder has not directly or indirectly induced or solicited any other bidder to put in a false or sham bid. The bidder has not directly or indirectly colluded, conspired, connived, or agreed with any bidder or anyone else to put in a sham bid, or to refrain from bidding. The bidder has not in any manner, directly or indirectly, sought by agreement, communication, or conference with anyone to fix the bid price of the bidder or any other bidder, or to fix any overhead, profit, or cost element of the bid price, or of that of any other bidder. All statements contained in the bid are true. The bidder has not, directly or indirectly, submitted his or her bid price or any breakdown thereof, or the contents thereof, or divulged information or data relative thereto, to any corporation, partnership, company, association, organization, bid depository, or to any member or agent thereof, to effectuate a collusive or sham bid, and has not paid, and will not pay, any person or entity for such purpose.

Any person executing this declaration on behalf of a bidder that is a corporation, partnership, joint venture, limited liability company, limited liability partnership, or any other entity, hereby represents that he or she has full power to execute, and does execute, this declaration on behalf of the bidder.

I declare under penalty of perjury under the laws of the State of California that the foregoing is true and correct and that this declaration is executed on _____[date], at _____[city], _____[state]."

DEBARMENT CERTIFICATION

By submitting its bid, the bidder certifies in accordance with California Public Contract Code Section 6109 that neither the bidder nor any subcontractor included on the list of proposed subcontractors submitted with the bid is ineligible to perform work on public works projects pursuant to California Labor Code Sections 1777.1 or 1777.7. In accordance with California Public Contract Code Section 6109, Contractors and subcontractors who are ineligible to perform work on public works projects pursuant to California Labor Code Sections 1777.1 or 1777.7 may neither bid on, be awarded or perform as a subcontractor on public works projects.

TITLE 49, CODE OF FEDERAL REGULATIONS - PART 29
DEBARMENT AND SUSPENSION CERTIFICATION

The bidder, under penalty of perjury, certifies that, except as noted below, he/she or any person associated therewith in the capacity of District, partner, director, officer, manager:

1. Is not currently under suspension, debarment, voluntary exclusion, or determination of ineligibility by any federal agency; and
2. Has not been suspended, debarred, voluntarily excluded or determined ineligible by any Federal Agency within the past 3 years; and
3. Does not have a proposed debarment pending; and,
4. Has not been indicted, convicted, or had a civil judgment rendered against it by a court of competent jurisdiction in any matter involving fraud or official misconduct within the past 3 years.

If there are any exceptions to this certification, insert the exceptions in the following space:

Exceptions will not necessarily result in denial of award, but will be considered in determining bidder responsibility. For any exception noted above, indicate below to whom it applies, initiating agency, and dates of action.

PUBLIC CONTRACT CODE SECTION 10285.1 STATEMENT

In accordance with Public Contract Code Section 10285.1 (Chapter 376, Stats, 1986), The bidder hereby declares under penalty of perjury under the laws of the State of California that the bidder has _____, has not _____ been convicted within the preceding three years of any offenses referred to in that section, including any charge of fraud, bribery, collusion, conspiracy, or any other act in violation of any state or federal antitrust law in connection with the bidding upon, award of, or performance of, any public works contract, as defined in Public Contract Code Section 1100, including the Regents of the University of California or the Trustees of the California State University. The term "bidder" is understood to include any partner, member, officer, director, responsible managing officer, or responsible managing employee thereof, as referred to in Section 10285.1.

Note: The bidder must place a check mark after "has" or "has not" in one of the blank spaces provided.

The above Statement is part of the Proposal. Signing the Contractor's Proposal on the signature portion thereof shall also constitute signature of this Statement.

Bidders are cautioned that making false certification may subject the certifier to criminal prosecution.

PUBLIC CONTRACT CODE SECTION 10162 QUESTIONNAIRE

In accordance with Public Contract Code Section 10162, The Bidder shall complete, under penalty of perjury, the following questionnaire:

Has the bidder, any officer of the bidder, or any employee of the bidder who has a proprietary interest in the bidder, ever been disqualified, removed, or otherwise prevented from bidding on, or completing a federal, state, or local government project because of a violation of law or a safety regulation?

Yes _____ No _____

If the answer is "Yes", explain the circumstances in the following space.

PUBLIC CONTRACT SECTION 10232 STATEMENT

In accordance with Public Contract Code Section 10232, the Contractor hereby states under penalty of perjury that no more than one final unappealable finding of contempt of court by a federal court has been issued against the Contractor within the immediately preceding two year period because of the Contractor's failure to comply with an order of a federal court which orders the Contractor to comply with an order of the National Labor Relations Board.

BIDDER'S SIGNATURE PAGE

By signing this proposal the bidder certifies, under penalty of perjury under the laws of the State of California, that the information submitted with this proposal for the Hidden Valley Lake Community Services District **MEADOW VIEW EASEMENT SEWER REHABILITATION PROJECT** ("Project"), which information includes, but is not limited to, the Bidder's Check List, Proposal and Schedule of Bid Prices, Bid Bond, Contractor License Information, List of Subcontractors, Workers Compensation Insurance Certification, Non-Collusion Declaration, Debarment Certification, Debarment and Suspension Certification, Public Contract Code Section 10285.1 Statement, Public Contract Code Section 10162 Questionnaire, Public Contract Code Section 10232 Statement and Bidder's Questionnaire, if any, is accurate, true and correct, and is submitted in accordance with the requirements of the bid package issued by the Hidden Valley Lake Community Services District concerning Project and applicable law. By signing this proposal the bidder representative specified below certifies that he or she is legally authorized to bind the bidder.

The bidder agrees to deliver and to complete the Project within **15 working days** from the date of issuance, by the District, of instructions to proceed with the Project, and within 10 days of the date of mailing of the notice of award, to enter into and execute and provide to the District the Project contract, bonds and all other documents specified in the Contract Check List included in the bid package, and in case of default in executing the Project contract within the time fixed by the Instructions to Bidders, the bidder's security accompanying this bid shall become the property of and be forfeited to the Hidden Valley Lake Community Services District.

Prime Contractor _____

By: _____ Title: _____

Dated this _____ day of _____, 2020

(Corporate Seal)

Corporate signature

Address: _____

Phone No.: _____

President's signature _____

Secretary's signature _____

Corporation organized under the laws of the State of _____

Partnership Name: _____

Address: _____

Names of Co-Partners and Addresses:

Names of Individuals and Addresses:

NOTE: Sign in proper space above.

Date: _____

(Typed or printed name)

(Signature)

(Bidder)

Bidder business address (street, city, state and zip code)

Bidder Business phone: () _____

Bidder Business fax: () _____

CONTRACT CHECK LIST

Complete, accurate, executed copies of the following documents must be submitted to the Hidden Valley Lake Community Services District in accordance with the bid package issued by the District within ten (10) working days of receiving written notice of award of the project. The bidder's security of any successful bidder that fails to do so will be forfeited to the District.

_____ Contract Check List

_____ Agreement

_____ Performance Bond

_____ Payment Bond

_____ Certificates of Insurance and Endorsements

_____ Escrow for Deposit Agreement, if applicable

_____ General Conditions

AGREEMENT

The Hidden Valley Lake Community Services District, (“District”) enters into this agreement, dated for reference purposes only, with _____ (“Contractor”).

RECITALS

- A. NOTICE INVITING BIDS. The District gave notice inviting bids to be submitted by **11:30 a.m. on September 10, 2020**, for the **MEADOW VIEW EASEMENT SEWER REHABILITATION PROJECT** by published notice and/or posting in accordance with California Public Contract Code Section 20164 and other applicable law.
- B. BID OPENING. On **September 10, 2020**, District representatives opened the bids for the **MEADOW VIEW EASEMENT SEWER REHABILITATION PROJECT** and read the bids aloud.
- C. PROJECT AWARD. On _____, the District awarded the **MEADOW VIEW EASEMENT SEWER REHABILITATION PROJECT** to the Contractor and directed District staff to send the Contractor written notice of award of the project. The District conditioned award of the project on the Contractor’s providing executed copies of all documents specified in the contract check list included in the bid package within ten (10) working days of receiving written notice of award of the project.
- D. REQUIRED DOCUMENTS. The Contractor has provided the District executed copies of all documents specified in the contract check list included in the bid package within ten (10) working days of receiving written notice of award.

AGREEMENT TERMS

The District and the Contractor agree as follows:

1. THE WORK. The Contractor shall furnish all equipment, tools, apparatus, facilities, material labor, and skill necessary to perform and complete in a good and workmanlike manner the **MEADOW VIEW EASEMENT SEWER REHABILITATION PROJECT** (“Work”) as shown in the Technical Specifications and Project Plans in accordance with the Contract Documents and applicable law.
2. LOCATION OF WORK. The Work will be performed at the following locations:
The sewer easement located on 17463 and 17451 Meadow View Drive and 19220 and 19232 Deer Hill Road.
3. TIME FOR COMPLETION. The Contractor must complete the Work in accordance with the Contract Documents within 15 working days from the date specified in the District’s Notice to Proceed (“Time for Completion”).
4. REMEDIES FOR FAILURE TO TIMELY COMPLETE THE WORK. If the Contractor fails to fully perform the Work in accordance with the Contract Documents by the Time for Completion, as such time may be amended by change order or other modification to this agreement in accordance with its terms, and/or if the Contractor fails, by the Time for Completion, to fully

perform all of the Contractor's obligations under this agreement that have accrued by the Time for Completion, the Contractor will become liable to the District for all resulting loss and damage in accordance with the Contract Documents and applicable law. The District's remedies for the Contractor's failure to perform include, but are not limited to, assessment of liquidated damages of **\$1,500 per day** in accordance with California Government Code Section 53069.85 and Section 7-1.02 of the General Provisions, and/or obtaining or providing for substitute performance in accordance with the Contract Documents.

5. CONTRACT PRICE AND PAYMENT. As full compensation in consideration of completion of the Work in accordance with the Contract Documents and in consideration of the fulfillment of all of the Contractor's obligations under the Contract Documents, the District will pay the Contractor in lawful money of the United States the total price of \$_____ (the "Contract Price") as specified in the Contractor's completed Bid Schedule dated _____, _____, and attached to and incorporated in this agreement. Payment to the Contractor under this agreement will be for Work actually performed in accordance with the Contract Documents and will be made in accordance with the requirements of the Contract Documents and applicable law. The District will have no obligation to pay the Contractor any amount in excess of the Contract Price unless this agreement is first modified in accordance with its terms. The District's obligation to pay the Contractor under this agreement is subject to and may be offset by charges that may apply to the Contractor under this agreement. Such charges include but are not limited to, charges for liquidated damages and/or substitute performance in accordance with the Contract Documents.
6. PREVAILING WAGES. In accordance with California Labor Code Section 1771, not less than the general prevailing rate of per diem wages for work of a similar character in the locality in which the Work is to be performed, and not less than the general prevailing rate of per diem wages for holiday and overtime work fixed as provided in the California Labor Code must be paid to all workers engaged in performing the Work. In accordance with California Labor Code Section 1770 and following, the Director of Industrial Relations has determined the general prevailing wage per diem rates for the locality in which the Work is to be performed. In accordance with California Labor Code Section 1773, the District has obtained the general prevailing rate of per diem wages and the general rate for holiday and overtime work in the locality in which the Work is to be performed for each craft, classification or type of worker needed to perform the project. In accordance with California Labor Code Section 1773.2, copies of the prevailing rate of per diem wages are on file at the office of Coastland Civil Engineering and will be made available on request. Throughout the performance of the Work the Contractor must comply with all provisions of the Contract Documents and all applicable laws and regulations that apply to wages earned in performance of the Work.
7. THE CONTRACT DOCUMENTS. This agreement consists of the following documents ("Contract Documents"), all of which are incorporated into and made a part of this agreement as if set forth in full. In the event of a conflict between or among the Contract Documents, precedence will be in the following order:
 - 7.1 This agreement and change orders and other amendments to this agreement signed by authorized representatives of the District and the Contractor.
 - 7.2 The General Provisions and change orders and other amendments to the General Conditions signed by authorized representatives of the District and the Contractor.

- 7.3 The Special Provisions, addenda to the Special Provisions signed by authorized representatives of the District and issued prior to bid opening, Equal Product Proposals accepted by the District and signed by authorized District representatives prior to bid opening, and change orders and other amendments to the Technical Specifications signed by authorized representatives of the District and the Contractor.
 - 7.4 The Project Plans, addenda to the Project Plans signed by authorized representatives of the District and issued prior to bid opening, Equal Product Proposals accepted by the District and signed by authorized District representatives prior to bid opening, and change orders and other amendments to the Project Plans signed by authorized representatives of the District and the Contractor.
 - 7.5 Notice Inviting Bids.
 - 7.6 Instructions to Bidders.
 - 7.7 The successful bidder's completed Proposal Form and Bidder's Sheet.
 - 7.8 The successful bidder's completed Contractor License Information.
 - 7.9 The successful bidder's completed List of Proposed Subcontractors.
 - 7.10 The successful bidder's Workers Compensation Insurance Certification.
 - 7.11 The successful bidder's completed Non-Collusion Declaration.
 - 7.12 The successful bidder's Debarment Certification.
 - 7.13 The successful bidder's completed Certificates of Insurance and Endorsements.
 - 7.14 The successful bidder's executed Performance Bond.
 - 7.15 The successful bidder's executed Payment Bond.
 - 7.16 Executed Escrow for Deposit Agreement, if applicable.
 - 7.17 Change Order Form.
 - 7.18 The Maintenance Bond form included in the bid package that the Contractor must execute prior to release of final payment under the Contract.
 - 7.19 The successful bidder's Qualification Statement, if any.
 - 7.20 The successful bidder's signed Signature Form.
8. PROVISIONS INCORPORATED BY REFERENCE. Provisions or parts of provisions that are incorporated by reference and not set forth at length in any of the Contract Documents will only form a part of this Agreement to the extent the Contract Documents expressly make such

provisions or parts of provisions a part of this Agreement. For example, published public works agreement provisions, such as those of the State of California Department of Transportation Standard Specifications (known as the Standard Specifications) are only a part of this Agreement to the extent expressly incorporated in this Agreement by section number, and references in the Standard Specifications incorporated by reference to other Standard Specifications do not make such other Standard Specifications a part of this Agreement. When such published provisions are made a part of this Agreement, references in the published provisions to other entities, such as the State, the Agency, or similar references, will be deemed references to the District as the context of this Agreement may require.

9. INTERPRETATION OF CONTRACT DOCUMENTS. Any question concerning the intent or meaning of any provision of the Contract Documents, including, but not limited to, the Technical Specifications or Project Plans, must be submitted to the District, for issuance of an interpretation and/or decision by an authorized District representative in accordance with the requirements of the Contract Documents. Interpretations or decisions by any other person concerning the Contract Documents will not be binding on the District. The decision of an authorized District representative shall be final.

10. ASSIGNMENT PROHIBITED. The Contractor may not assign part or all of this agreement, or any moneys due or to become under this agreement, or any other right or interest of the Contractor under this agreement, or delegate any obligation or duty of the Contractor under this agreement without the prior written approval of an official authorized to bind the District and an authorized representative of Contractor's surety or sureties. Any such purported assignment or delegation without such written approval on behalf of the District and the Contractor's sureties will be void and a material breach of this agreement subject to all available remedies under this agreement and at law and equity.

11. CERTIFICATION RE CONTRACTOR'S LICENSE. By signing this Agreement the Contractor certifies that the Contractor holds a valid Type A license issued by the California State Contractors Licensing Board, and that the Contractor understands that failure to maintain its license in good standing throughout the performance of the Work may result in discipline and/or other penalties pursuant to the California Business and Professions Code, and may constitute a material breach of this agreement subject to all available remedies under this agreement and at law and equity.

12. SEVERABILITY. If any term or provision or portion of a term or provision of this Agreement is declared invalid or unenforceable by any court of lawful jurisdiction, then the remaining terms and provisions or portions of terms or provisions will not be affected thereby and will remain in full force and effect.

Executed on _____, _____, by

CONTRACTOR

HIDDEN VALLEY LAKE COMMUNITY
SERVICES DISTRICT

By: _____

By: _____

Title: _____

Title: President, Board of Directors

[Attach Notary Page]

Attest:

By: _____

Title: Clerk of the Board

PERFORMANCE BOND

(NOTE: Bidders must use this form, use of any other bond form may render a bid non-responsive)

KNOW ALL MEN BY THESE PRESENTS:

WHEREAS the Board of Directors of the Hidden Valley Lake Community Services District has awarded to _____ (designated as the “PRINCIPAL”) a contract for the **MEADOW VIEW EASEMENT SEWER REHABILITATION PROJECT**, which contract and all of the contract documents as defined therein (designated as the “Contract”) are hereby made a part hereof; and

WHEREAS, said PRINCIPAL is required under the terms of the Contract to furnish a bond for the faithful performance of the Contract;

NOW, THEREFORE, WE, the PRINCIPAL and _____ as surety (designated as “SURETY”), an admitted surety insurer authorized to do business in the State of California, are held and firmly bound unto the District (designated as “OBLIGEE”), in the penal sum of _____ dollars (\$ _____), lawful money of the United States for the payment of which sum well and truly to be made, we bind ourselves, our heirs, executors, and administrators, and successors, jointly and severally, firmly by these presents.

THE CONDITION OF THIS OBLIGATION IS SUCH that, if the above bound PRINCIPAL, his or its heirs, executors, administrators, successors, or assigns, shall in all things stand to and abide by, and well and truly keep and perform the covenants, conditions and agreements in the Contract and any alteration thereof made as therein provided, on his or their part to be kept and performed at the time and in the manner therein specified and in all respects according to their true intent and meaning, and shall defend, indemnify and save harmless the OBLIGEE, it’s officials, officers, employees, volunteers and agents, as therein stipulated, then this obligation shall become null and void, otherwise it shall be and remain in full force and virtue.

And the said SURETY, for value received, hereby stipulates and agrees that no change, extension of time, alteration or addition to the terms of the Contract or to the work to be performed thereunder or to the specifications or the plans accompanying the same or to any other part of the contract documents, as defined therein, shall in any way affect said SURETY’s obligation on this bond, and the SURETY does hereby waive notice of any such change, extension of time, alteration or addition.

And the said SURETY, for value received, hereby stipulates and agrees that upon termination of the Contract for cause, the OBLIGEE reserves the right to refuse tender of the PRINCIPAL by the SURETY to complete the Contract work.

IN WITNESS WHEREOF, the above-bound parties have executed this instrument under their several seals this _____ day of _____, _____, the name and corporate seals of each corporate party being hereto affixed and these presents duly signed by their undersigned representatives, pursuant to authority of their governing bodies.

(Corporate Seal) PRINCIPAL _____

By _____

(Acknowledgment) Title _____

(Corporate Seal) SURETY _____

By _____
(Attorneys-in-fact)

(Acknowledgment) Title _____

(NOTE TO SURETY COMPANY: A certified copy of unrevoked resolution of authority for the attorney-in-fact must be submitted with and attached to the executed bond.)

PAYMENT/LABOR AND MATERIALS BOND

(NOTE: Bidders must use this form, use of any other bond form may render a bid non-responsive)

KNOW ALL MEN BY THESE PRESENTS:

WHEREAS the Board of Directors of the Hidden Valley Lake Community Services District has awarded to _____ (designated as the “PRINCIPAL”) a contract for the **MEADOW VIEW EASEMENT SEWER REHABILITATION PROJECT**, which contract and all of the contract documents as defined therein (designated as the “Contract”) are hereby made a part hereof; and

WHEREAS, pursuant to California Civil Code Section 9550, the PRINCIPAL is required, before entering upon the performance of the Contract, to file a payment bond with and have such bond approved by the officer or public entity by whom the Contract is awarded; and

WHEREAS, pursuant to California Civil Code Section 9554, such payment bond must be in a sum not less than one hundred percent (100%) of the total amount payable by the terms of the Contract, and must satisfy the other requirements specified in that section; and

WHEREAS, the PRINCIPAL is required in accordance with the Contract to furnish a payment bond in connection with the Contract to secure payment of claims of laborers, mechanics and materialmen employed on work under the Contract in accordance with applicable law;

NOW, THEREFORE, THESE PRESENTS WITNESSETH:

That the PRINCIPAL and the undersigned _____, as surety (designated as “SURETY”), an admitted surety insurer authorized to do business in the State of California are held and firmly bound unto all laborers, material men, and all other persons named in California Civil Code Section 9100 in the sum of _____ Dollars (\$ _____), lawful money of the United States, being a sum not less than one hundred percent of the total amount payable by the terms of the Contract, for the payment of which sum well and truly to be made, we bind ourselves, our heirs, executors, administrators, successors, or assigns, jointly and severally, by these presents.

THE CONDITION OF THIS OBLIGATION IS SUCH that if the PRINCIPAL or any of the PRINCIPAL’s subcontractors, or the heirs, executors, administrators, successors, or assigns of any, all, or either of them, shall fail to pay any persons named in California Civil Code Section 9100, or fail to pay for any labor, materials, provisions, provender, or other supplies used in, upon, for or about the performance of the work contracted to be done, or for any work or labor thereon of any kind, or fail to pay amounts due under the Unemployment Insurance Code with respect to such work or labor, or fail to pay for any amounts required to be deducted, withheld, and paid over to the Employment Development Department from the wages of employees of the PRINCIPAL or any subcontractors of the PRINCIPAL pursuant to Section 13020 of the Unemployment Insurance Code with respect to such work or labor, that the SURETY will pay for the same in an amount not exceeding the amount herein above set forth, and also, in case suit is brought upon this bond, will pay a reasonable attorney’s fee to be awarded and fixed by the Court; otherwise this obligation shall be void.

It is hereby expressly stipulated and agreed by the said Surety, for value received, that this bond shall inure to the benefit of any and all of the persons named in Section 9100 of the California Civil Code so as to give a right of action to them or their assigns in any suit brought upon this bond.

It is hereby further expressly stipulated and agreed by the said Surety, for value received, that no change, extension of time, alteration or addition to the terms of the Contract or the specifications or drawings accompanying the same or to any other part of the contract documents, as defined therein, shall in any manner affect the obligations of the SURETY on this bond, and SURETY does hereby waive notice of any such change, extension, alteration, or addition.

IN WITNESS WHEREOF, the above-bound parties have executed this instrument under their several seals this _____ day of _____, _____, the name and corporate seals of each corporate party being hereto affixed and these presents duly signed by their undersigned representatives, pursuant to authority of their governing bodies.

(Corporate Seal) PRINCIPAL _____

By _____

(Acknowledgment) Title _____

(Corporate Seal) SURETY _____

By _____
(Attorneys-in-fact)

(Acknowledgment) Title _____

(NOTE TO SURETY COMPANY: A certified copy of unrevoked resolution of authority for the attorney-in-fact must be submitted with and attached to the executed bond.)

HIDDEN VALLEY LAKE COMMUNITY SERVICES DISTRICT

19400 Hartmann Rd., Hidden Valley Lake, CA 95467

ORDER NO
DATE
STATE California
COUNTY Lake

CONTRACT CHANGE ORDER

CONTRACT FOR MEADOW VIEW EASEMENT SEWER REHABILITATION PROJECT

CONTRACT NO:

OWNER: Hidden Valley Lake Community Services District

CONTRACTOR:

CURRENT CONTRACT PRICE:

CURRENT CONTRACT TIME OF COMPLETION:

CURRENT NO. WORKING DAYS

TO:

(Contractor)

You are hereby requested to comply with the following changes from to the contract plans, specifications, or other contract documents:

Description of Changes (Supplemental Plans and Specifications Attached)	DECREASE in Contract Price	INCREASE In Contract Price
1)		
TOTALS	\$ -	\$ -
NET CHANGE IN CONTRACT PRICE	\$ 0.00	

JUSTIFICATION:

The amount of the Contract will be (Decreased) (Increased) By The Sum Of:

\$ -

The Contract Total Including this and previous Change Orders Will Be:

The Contract Period Provided for Completion Will Be (Increased) (Decreased) (Unchanged): _____ Days
 Contract Completion Date

Upon execution by representatives authorized to bind the parties, this Change Order will become a part of the contract. The consideration specified in this Change Order (whether an adjustment of the contract price, an adjustment of time, and/or other consideration) is the full and sole compensation owed to the contractor as a result of the changes and issues described in this Change Order. Such consideration includes, but is not limited to, any and all direct and indirect costs incurred by the contractor as a result of the changes and issues described in this Change Order for any labor, equipment, materials, overhead (additional, extended, field and home office), profit, or time adjustments. By signing this Change Order the contractor waives and releases the owner from any and all claims for additional compensation concerning any of the changes and issues specified in this Change Order.

The undersigned, being the _____ (Title) of the Contractor, by signing this Changer Order declares under penalty of perjury under the laws of the State of California, and does personally certify and attest that: the undersigned has thoroughly reviewed the attached request for change order and knows its contents, and said request for change order is made in good faith; that it is supported by truthful and accurate data; that the amount requested and the additional time requested accurately reflect the allowable expenses that would be incurred, and the time necessary, to perform the change order; and further, that the undersigned is familiar with California Penal Code Section 72 and California Government Code Section 12650 et seq., pertaining to false claims, and further knows and understands that the submission or certification of a false claim may lead to fines, imprisonment, or other severe legal consequences.

Requested _____ (Owner) (Date)

Recommended _____ (Owner's Architect/Engineer) (Date)

Accepted _____ (Contractor) (Date)

Approved by Agency _____ (Name and Title) (Date)

925984

MAINTENANCE BOND

(NOTE: Bidders must use this form, use of any other bond form may render a bid non-responsive)

KNOW ALL MEN BY THESE PRESENTS:

WHEREAS the Board of Directors of the Hidden Valley Lake Community Services District has awarded to _____ (designated as the "PRINCIPAL") a contract for the **MEADOW VIEW EASEMENT SEWER REHABILITATION PROJECT** which contract and all of the contract documents as defined therein (designated as the "Contract") are hereby made a part hereof; and

WHEREAS, the PRINCIPAL is required under the terms of the Contract to furnish a bond for the correction of any defects due to defective materials or workmanship in the work performed under the Contract.

NOW, THEREFORE, we the PRINCIPAL and the undersigned _____, as surety (designated as "SURETY"), an admitted surety insurer authorized to do business in the State of California, are held and firmly bound unto the Hidden Valley Lake Community Services District, (designated as the "OBLIGEE"), in the penal sum of _____ Dollars (\$ _____), lawful money of the United States, being a sum not less than twenty percent (20%) of the final Contract price, for the payment of which sum well and truly to be made, we bind ourselves, our heirs, executors, administrators, successors, and assigns jointly and severally, firmly by these presents.

THE CONDITIONS OF THIS OBLIGATION ARE SUCH that if, during a maintenance period of one (1) year from the date of acceptance by the OBLIGEE of the contracted work, the PRINCIPAL upon receiving written notice of a need for repairs which are directly attributable to defective materials or workmanship, shall diligently take the necessary steps to correct said defects within seven (7) days from the date of said notice, then this obligation shall be null and void; otherwise it shall remain in full force and effect.

If any action shall be brought by the OBLIGEE upon this bond, a reasonable attorney's fee, to be fixed by the Court, shall be and become a part of OBLIGEE's judgment in any such action.

No right of action shall accrue on this bond to, or for the use of, any person or corporation other than the OBLIGEE named herein or the heirs, executors, administrator or successor of the OBLIGEE.

IN WITNESS WHEREOF, the above bound parties have executed this instrument under their seals this _____ day of _____, the name and corporate seals of each corporate party being hereto affixed and these presents duly signed by its undersigned representative, pursuant to authority of its governing body.

(Corporate Seal) PRINCIPAL _____

By _____

(Acknowledgment) Title _____

(Corporate Seal)

SURETY _____

By _____
(Attorneys-in-fact)

(Acknowledgment)

Title _____

(NOTE TO SURETY COMPANY: A certified copy of unrevoked resolution of authority for the attorney-in-fact must be submitted with and attached to the executed bond.)

**ESCROW AGREEMENT FOR
SECURITY DEPOSITS IN LIEU OF RETENTION**

This Escrow Agreement is made and entered into by and between the Hidden Valley Lake Community Services District, whose address is 19400 Hartmann Rd., Hidden Valley Lake, California 95467 hereinafter called "District", and _____, hereinafter called "Contractor", whose address is _____ and _____, whose address is _____, hereinafter called "Escrow Agent"

For consideration hereinafter set forth, the District, Contractor, and Escrow Agent agree as follows:

1. Pursuant to Section 22300 of the Public Contract Code of the State of California, Contractor has the option to deposit securities with Escrow Agent as a substitute for retention earnings required to be withheld by District pursuant to the Construction Contract entered into between the District and Contractor for the project entitled **MEADOW VIEW EASEMENT SEWER REHABILITATION PROJECT** in the amount of _____ dated _____ (hereinafter referred to as the "Contract"). Alternatively, on written request of the Contractor, the District shall make payments of the retention earnings directly to the Escrow Agent. When Contractor deposits the securities as substitute for Contract earnings, the Escrow Agent shall notify the District within 10 days of the deposit. The market value of the securities at the time of the substitution shall be at least equal to the cash amount then required to be withheld as retention under the terms of the Contract between the District and Contractor. Securities shall be held in the name of _____ and shall designate the Contractor as the beneficial owner.
2. The District shall make progress payments to the Contractor for such funds which otherwise would be withheld from progress payments pursuant to the Contract provisions, provided that the Escrow Agent holds securities in the form and amount specified above.
3. When the District makes payment of retentions earned directly to the Escrow Agent, the Escrow Agent shall hold them for the benefit of the Contractor until such time as the escrow created under this contract is terminated. The Contractor may direct the investments of the payments into securities. All terms and conditions of this agreement and the rights and responsibilities of the parties shall be equally applicable and binding when the District pays the escrow agent directly.
4. Contractor shall be responsible for paying all fees for the expenses incurred by Escrow Agent in administering the Escrow Account and all expenses of the District. These expenses and payment terms shall be determined by the District, Contractor and Escrow Agent.
5. The interest earned on the securities or the money market accounts held in escrow and all interest earned on that interest shall be for the sole account of the Contractor and shall be subject to withdrawal by Contractor at any time and from time to time without notice to the District.
6. Contractor shall have the right to withdraw all or any part of the principal in the Escrow Account only by written notice to Escrow Agent accompanied by written authorization from District to the Escrow Agent that District consents to the withdrawal of the amount sought to be withdrawn by Contractor.
7. The District shall have a right to draw upon the securities in the event of default by the Contractor. Upon seven day's written notice to the Escrow Agent from the District of the default, the Escrow

Agent shall immediately convert the securities to cash and shall distribute the cash as instructed by the District.

- 8. Upon receipt of written notification from the District certifying that the Contract is final and complete, and that the Contractor has complied with all requirements and procedures applicable to the Contract, Escrow Agent shall release to Contractor all securities and interest on deposit less escrow fees and charges of the Escrow Account. The escrow shall be closed immediately upon disbursement of all monies and securities on deposit and payments of fees and charges.
- 9. Escrow Agent shall rely on the written notifications from the District and the Contractor pursuant to Sections (4) to (6) inclusive, of this agreement and the District and Contractor shall hold Escrow Agent harmless from Escrow Agent's release and disbursement of the securities and interest as set forth above.
- 10. The names of the persons who are authorized to give written notice or to receive written notice on behalf of the District and on behalf of Contractor in connection with the foregoing, and exemplars of their respective signatures, are as follows:

On behalf of District:

Title: _____

Name: _____

On Behalf of Contractor:

Title: _____

Name: _____

On behalf of Escrow Agent:

Title

Name

Signature

Address

At the time the Escrow Account is opened, the District and Contractor shall deliver to the Escrow Agent a fully executed counterpart of this Agreement.

IN WITNESS WHEREOF, the parties have executed this Agreement by their proper officers on the date first set forth above.

District:

Contractor:

Title

Title

Name

Name

Signature

Signature

Address

Address

GENERAL PROVISIONS

SECTION 1 DEFINITIONS

The following terms as used in any agreement of which these General Provisions are a part are defined as follows:

- 1-1.01 Agreement:** The agreement between the District and Contractor concerning the Project, as evidenced by and comprised of the Contract Documents.
- 1-1.02 Base:** A layer of specified material of planned thickness placed immediately below the pavement or surfacing.
- 1-1.03 Base Material:** The material in excavation or embankments underlying the lowest layer of subbase, base, pavement, surfacing or other specified layer which is to be placed.
- 1-1.04 Bid Package:** All of the documents listed as comprising the entire Bid Package as specified in the Instructions to Bidders and representing the full set of documents made available to bidders on the Project.
- 1-1.05 Bridge:** Any structure, with a bridge number, which carries a utility facility, or railroad, highway, pedestrian or other traffic, over a water course or over or under or around any obstruction.
- 1-1.06 Caltrans:** The Department of Transportation of the State of California, as created by law.
- 1-1.07 Change Order:** Amendment to the Agreement, the Project Plans, Technical Specifications or other Contract Documents in accordance with Section 3, Control of Work and Material and Changes in Work, of the General Provisions.
- 1-1.08 District:** Hidden Valley Lake Community Services District.
- 1-1.09 Conduit:** A pipe or tube in which smaller pipes, tubes or electrical conductors are inserted or are to be inserted.
- 1-1.10 Contract Documents:** All those documents listed in the Project agreement as comprising the entire agreement between the District and the Contractor.
- 1-1.11 Contractor:** The successful bidder for the Project and party to the Project agreement with the District as specified in the Project agreement.

- 1-1.12 Culvert:** Any structure, other than a bridge, which provides an opening under a roadway for drainage or other purposes.
- 1-1.13 Days:** Unless otherwise specified in the Contract Documents, days mean working days.
- 1-1.14 Designer:** The person or persons so specified on the Technical Specifications and/or Project Plans.
- 1-1.15 Detour:** A temporary route for traffic around a closed portion of a road.
- 1-1.16 Divided Highway:** A highway with separated traveled ways for traffic, generally in opposite directions.
- 1-1.17 Engineer:** The District's authorized representative for administration and overall management of the Project agreement and Work. The Engineer is the official point of contact between the District and the Contractor.
- 1-1.18 Frontage Road:** A local street or road auxiliary to and located generally on the side of an arterial highway for service to abutting property and adjacent areas and for control of access.
- 1-1.19 Grading Plane:** The surface of the basement material upon which the lowest layer of subbase, base, pavement, surfacing or other specified layer is placed.
- 1-1.20 Highway:** The whole right of way or area which is reserved for and secured for use in constructing the roadway and its appurtenances.
- 1-1.21 Laboratory:** The established laboratory of the Materials and Research Department of the Department of Transportation of the State of California or laboratories authorized by the Engineer to test materials involved in the contract.
- 1-1.22 Manual on Uniform Traffic Control Devices:** The latest edition of the California Manual on Uniform Traffic Control Devices.
- 1-1.23 Median:** That portion of a divided highway separating the traveled ways for traffic in opposite directions including inside shoulders.
- 1-1.24 Office of Structure Design:** The Offices of Structure Design of the Department of Transportation. When the specifications require working drawings to be submitted to the Offices of Structure Design, the drawings shall be submitted to: Offices of Structure Design, Documents Unit, Mail Station 9-4/4I, 1801 30th Street, Sacramento, CA 95816, Telephone (916) 227-8252.
- 1-1.25 Pavement:** The uppermost layer of material placed on the traveled way or shoulders. This term is used interchangeably with surfacing.

- 1-1.26 Processing:** Any operation or operations of whatever nature and extent required to produce a specified material.
- 1-1.27 Project:** The **Wastewater Treatment Plant Access Road & Pond Levee Repairs** as described in the Technical Specifications and Project Plans.
- 1-1.28 Project Inspector:** The party or parties charged by the District with inspecting the Work for compliance with the requirements of the Contract Documents and applicable laws and regulations. The Project Inspector acts under the direction of the District and shall coordinate with the District as directed by the District in accordance with the Contract Documents.
- 1-1.29 Project Plans:** The primarily graphic detailed requirements concerning the Project contained in the Bid Package and any addenda to the Project Plans signed by authorized District representatives and issued prior to bid opening, Equal Product Proposals accepted by the District and signed by authorized District representatives prior to bid opening, and change orders and other amendments to the Project Plans signed by authorized representatives of the District and the Contractor in accordance with the requirements of the Contract Documents.
- 1-1.30 Roadbed:** The roadbed is that area between the intersection of the upper surface of the roadway and the side slopes or curb lines. The roadbed rises in elevation as each increment or layer of subbase, base, surfacing or payment is placed. Where the medians are so wide as to include areas of undisturbed land, a divided highway is considered as including 2 separate roadbeds.
- 1-1.31 Roadway:** That portion of the highway included between the outside lines of sidewalks, or curbs, slopes, ditches, channels, waterways, and including all the appertaining structures, and other features necessary to proper drainage and protection.
- 1-1.32 Shoulders:** The portion of the roadway contiguous with the traveled way for accommodation of stopped vehicles, for emergency use, and for lateral support of base and surface courses.
- 1-1.33 Special Provisions:** The special provisions set forth conditions or requirements peculiar to the Work and supplementary to the General Provisions.
- 1-1.34 Standard Specifications:** The directions, provisions and requirements contained in the Caltrans Specifications.
- 1-1.35 Subbase:** A layer of specified material of planned thickness between a base and the basement material.
- 1-1.36 Subcontractor:** A person, firm or corporation that is obligated as a party to a contract with the Contractor to perform part of the Project work. For purposes of

these General Provisions Subcontractors include, but are not limited to, those that are obligated as parties to a contract with the Contractor to specially fabricate and install a portion of the Project Work according to the Technical Specifications and/or Project Plans.

1-1.37 Subgrade: That portion of the roadbed on which pavement, surfacing, base, subbase, or a layer of any other material is placed.

1-1.38 Substructure: All that part of the bridge below the bridge seats, tops of piers, haunches of rigid frames, or below the spring lines of arches. Backwalls and parapets of abutments and wingwalls of bridges shall be considered as parts of the substructure.

1-1.39 Superstructure: All that part of the bridge except the bridge substructure.

1-1.40 Surfacing: The uppermost layer of material placed on the traveled way, or shoulders. This term is used interchangeably with pavement.

1-1.41 Technical Specifications: The detailed Project requirements contained in the Bid Package and any addenda to the Technical Specifications signed by authorized District representatives and issued prior to bid opening, Equal Product Proposals accepted by the District and signed by authorized District representatives prior to bid opening, and change orders and other amendments to the Technical Specifications signed by authorized representatives of the District and the Contractor in accordance with the requirements of the Contract Documents.

1-1.42 Traffic Lane: That portion of a traveled way for the movement of a single line of vehicles.

1-1.43 Traveled Way: That portion of the roadway for the movement of vehicles, exclusive of the shoulders.

1-1.44 Work: The furnishing of all equipment, tools, apparatus, facilities, material, labor and skill necessary to perform and complete in a good and workmanlike manner the Project as shown in the Technical Specifications and Project Plans in accordance with the Contract Documents and applicable law.

1-1.45 Written Notice: Will be deemed to have been duly served for purposes of these General Provisions and any agreement of which they are a part if delivered in person to the individual or to a member of the firm or to any office of the corporation for whom the notice is intended, or if sent by registered or certified mail to the last known business address known to the party giving notice. Unless otherwise specified in the Contract Documents, the last known address of the Contractor shall be that listed in the Contractor's completed Proposal and Schedule of Bid Prices.

SECTION 2

SCOPE OF WORK

2-1.01 Documents Furnished by District. The District will furnish to the Contractor, free of charge three (3) sets of prints of the Project Plans and Technical Specifications for execution of the Work. Throughout the performance of the Work the Contractor must keep one copy of the Project Plans and Technical Specifications in good order and available for review by the Engineer, the Designer, and any other District contractors or representatives.

2-1.02 Ownership of Documents Furnished by District. All documents furnished by the District, including, but not limited to, the Technical Specifications, Project Plans, and any copies, are the property of the District. Documents furnished by the District may not to be used on any other work. All documents furnished by the District must be returned to District upon completion of the Work.

2-1.03 Technical Specifications and Project Plans.

- a. The Technical Specifications and Project Plans are complementary and intended to mutually describe the Work necessary to complete the Project in accordance with the Contract Documents.
- b. In general, the Project Plans indicate dimensions, position and kind of construction, and the Technical Specifications indicate qualities and methods. Any Work indicated on the Project Plans and not mentioned in the Technical Specifications or vice versa must be furnished as though fully set forth in both. Work that is not particularly detailed, marked or specified shall be the same as similar Work that is detailed, marked or specified. The Contractor must furnish items necessary for the operation of equipment depicted in the Project Plans or specified in the Technical Specifications that are suitable to allow such equipment to function properly at no extra charge.
- c. The Contractor must notify the Engineer as soon as possible of any apparent errors or inconsistencies, including, but not limited to, typographical or notational errors in the Project Plans, Technical Specifications, and/or in work done by others affecting the Work. The Engineer will issue instructions concerning any such apparent errors or inconsistencies. If the Contractor proceeds with Work impacted by apparent errors or inconsistencies without instructions from the Engineer, the Contractor shall do so at its sole risk and shall have all of the obligations and the District shall have all of the rights and remedies specified in Section 9 concerning any resulting damage or defect.
- d. The General Provisions apply with equal force to all of the Work, including extra work authorized by the Engineer in accordance with the Contract Documents. The Contractor must submit any required shop diagrams and/or

drawings by the times and in the quantities indicated in the Technical Specifications. Any such shop diagrams and/or drawings must show completely the Work to be done, expanding on the Project Plans concerning details not previously shown, field conditions and the condition of the Work. Engineer review of such shop diagrams and/or drawings will concern conformance with the requirements of the Contract Documents only. The Engineer assumes no responsibility for the correctness or accuracy of the dimensions or any other contents of any shop diagrams and/or drawings submitted by the Contractor. The Contractor must check all dimensions at the Work site. Shop diagrams and/or drawings must be clearly marked with the name of the Project and the name of the Contractor, subcontractor or supplier making the submittal, and must be stamped and signed by the Contractor and submitted under a signed transmittal letter from the Contractor certifying that all dimensions have been checked at the Work site. These requirements are mandatory. The Engineer will not review shop diagrams and/or drawings that do not satisfy these requirements. The Contractor will be responsible for any and all discrepancies between dimensions of the actual Project site and/or Work and those shown on shop diagram and/or drawings submitted by the Contractor, and for any other errors contained in or resulting from such shop diagrams and/or drawings, including, but not limited to, errors in material and/or equipment quantities and any resulting errors, delays or additional cost in the performance of the Work. The Contractor will have all of the obligations and the District will have all of the rights and remedies that are specified in Section 9, Remedies and Disputes, concerning any discrepancies or errors in shop diagrams and/or drawings submitted by the Contractor, and concerning any resulting errors, delays or additional costs in the performance of the Work.

2-1.04 Pre-Construction Conference. Prior to the issuance of the Notice to Proceed, a pre-construction conference will be held at the Office of the District for the purpose of discussing with the Contractor the scope of work, Contract drawings, specifications, existing conditions, materials to be ordered, equipment to be used, and all essential matters pertaining to the prosecution of and the satisfactory completion of the project as required. The Contractor's representative at this conference shall include all major superintendents for the work and may include major subcontractors.

SECTION 3 CONTROL OF WORK AND MATERIAL AND CHANGES IN THE WORK

3-1.01 Engineer's Status. The Engineer will administer the Project in accordance with the Contract Documents. After execution of the agreement and issuance of the Notice to Proceed, all correspondence and/or instructions concerning the Project between the Contractor and/or District shall be forwarded through the Engineer. Except as otherwise provided in the Contract Documents, the Engineer will not be responsible for and will not have control or charge of construction means, methods, techniques, or procedures or for safety precautions in connection with the Work. The Engineer, however, will have authority to reject materials and/or workmanship that do not conform to the requirements of the Contract Documents. The Engineer will also have the authority to require inspection or testing of the Work.

3-1.02 Designer's Status. The Designer will advise the Engineer concerning decisions on all claims of the Contractor and all other matters relating to the execution and progress of the Work or the interpretation of the Contract Documents. The Designer will also advise the Engineer concerning Work that does not conform to the Contract Documents. Whenever, in the Designer's opinion, it is necessary or advisable in accordance with the Contract Documents, the Designer may recommend to the Engineer inspection or testing of the Work, whether or not such Work is then fabricated, installed or completed.

3-1.03 Inspection and Testing of Work and Material.

- a. The District, the Engineer, the Designer and their representatives will have access to the Work at all times wherever it is in preparation or progress. The Contractor must provide proper facilities for such access and for inspection. The Contractor shall furnish the Engineer a list of the Contractor's sources of materials and the locations at which those materials will be available for inspection. The list shall be furnished to the Engineer in sufficient time to permit inspecting and testing of materials to be furnished from the listed sources in advance of their use. Within three (3) business days of receipt of the list, the Engineer may inspect, sample or test materials at the source of supply or other locations, but the inspection, sampling or testing will not be undertaken until the Engineer is assured by the Contractor of the cooperation and assistance of both the Contractor and the supplier of the material. The Contractor shall assure that the Engineer or the Engineer's authorized representative has free access at all times to the material to be inspected, sampled or tested. Adequate facilities shall be furnished free of charge to make the necessary inspection. The District assumes no obligation to inspect materials at the source of supply. It is understood that the inspections and tests if made at any point other than the point of incorporation in the Work in no way shall be considered as a guaranty

of acceptance of the material nor of continued acceptance of material presumed to be similar to that upon which inspections and tests have been made, and that inspection and testing performed by the District shall not relieve the Contractor or the Contractor's suppliers of responsibility for quality control.

- b. The Contractor must inspect all materials as delivered and promptly return all defective materials without waiting for their rejection by the Designer or Engineer. The Contractor shall be responsible for controlling the quality of the material entering the Work and of the Work performed, and shall perform testing as necessary to ensure control. The test methods used for quality control testing shall be as determined by the Contractor and this Agreement. The results of the testing shall be made available to the Engineer upon request. These tests are for the Contractor's use in controlling the Work and will not be accepted for use as acceptance tests. Full compensation for performing quality control tests and making the results available to the Engineer shall be considered as included in the Contract Prices and no additional compensation will be allowed therefore.
- c. If the Engineer, the Technical Specifications, or any laws, ordinances, or any public authority require any Work to be tested or approved, the Contractor must give the Engineer timely notice of the Contractor's readiness for inspection. Inspections will be promptly made, and where practicable, at the source of supply. Any work subject to such testing that is covered up without timely notice to the Engineer or without the approval or consent of the Engineer must, if required by the Engineer, be uncovered for examination at the Contractor's expense. The Contractor will have all of the obligations and the District will have all of the rights and remedies that are specified in Section 9 concerning any work subject to testing that is covered up without timely notice to the Engineer and that is not uncovered for examination at the Contractor's expense if required by the Engineer.
- d. Tests of materials or qualification tests required by the Contract Documents must be made in accordance with the Technical Specifications and the requirements of the California Building Standards Code, where applicable, as adopted by the District, and other applicable law. Copies of all testing reports shall be distributed as required in the Technical Specifications. The laboratory or inspection agency shall be selected by the District. The District will pay for all laboratory inspection service direct, and not as a part of the contract. Materials of construction, particularly those upon which the strength and durability of the structure may depend, shall be subject to inspection and testing to establish conformance with specifications and suitability for uses intended.
- e. The District or its representatives may order re-examination of questioned Work. If ordered to do so, the Contractor must uncover such Work. If such Work is found to be according to the Contract Documents, the District shall pay the cost of uncovering and restoring the Work, unless such Work was subject to testing and covered up without timely notice to or approval of the Engineer.

If re-examined Work is found not in accordance with the Contract Documents, the Contractor must pay the cost of uncovering and restoring the Work. The Contractor will have all of the obligations and the District will have all of the rights and remedies that are specified in Section 9 concerning any re-examined Work not in accordance with the Contract Documents that the Contractor fails to uncover and restore at the Contractor's expense.

- f. The Contractor must replace or correct without charge any material or workmanship found not to conform to the requirements of the Contract Documents, unless the District consents to accept such material or workmanship with an appropriate adjustment in the Contract Price. The Contractor must promptly segregate and remove non-conforming material from the Work site. The Contractor will have all of the obligations and the District will have all of the rights and remedies that are specified in Section 9 concerning any failure by the Contractor to replace or correct without charge any material or workmanship that does not conform to the requirements of the Contract Documents and that the District has not consented to accept.
- g. Any work done beyond the lines and grades shown on the Project Plans or established by the Engineer, or any extra work done without written authority will be considered as unauthorized work and will not be paid for. Upon order of the Engineer unauthorized work shall be remedied, removed or replaced at the Contractor's expense.
- h. The inspection of the Work or materials shall not relieve the Contractor of any of the Contractor's obligations to fulfill the Agreement. Work and materials not meeting Agreement requirements shall be made good, and unsuitable Work of materials may be rejected, notwithstanding that the Work or materials have been previously inspected by the Engineer or that payment therefore has been given.
- i. Unless otherwise specified, all tests shall be performed in accordance with the methods used by Caltrans and shall be made by the Engineer or the Engineer's designated representative.
- j. The District has developed methods for testing the quality of materials and work. These methods are identified by number and are referred to in the Technical Specifications as California Tests. Copies of individual California Tests are available at the Transportation Laboratory, Sacramento, California, and will be furnished to interested persons upon request.
- k. Whenever the specifications require compliance with specified values for the following properties, tests will be made by the California Test indicated unless otherwise specified:

Properties	California Test
Relative Compaction	216 or 231
Sand Equivalent	217
Resistance (R-value)	301
Grading (Sieve Analysis)	202
Durability Index	229

- l. Whenever a reference is made in the Technical Specifications to a California Test by number, it shall mean the California Test in effect on the day the Agreement is signed on behalf of the District.
- m. Whenever the Technical Specifications provide an option between 2 or more tests, the Engineer will determine the test to be used.
- n. Whenever a reference is made in the Technical Specifications to a specification, manual or test designation either of the American Society for Testing and Materials, the American Association of State Highway and Transportation Officials, Federal Specifications or any other recognized national organization, and the number or other identification representing the year of adoption or latest revision is omitted, it shall mean the specification, manual or test designation in effect on the day the Agreement is signed on behalf of the District. Whenever the specification, manual or test designation provides for test reports (such as certified mill test reports) from the manufacturer, copies of those reports, identified as to the lot of material, shall be furnished to the Engineer. The manufacturer's test reports shall supplement the inspection, sampling and testing provisions in this Section, and shall not constitute a waiver of the District's right to inspect. When material which cannot be identified with specific test reports is proposed for use, the Engineer may, at the Engineer's discretion, select random samples from the lot for testing. Test specimens from the random samples, including those required for retest, shall be prepared in accordance with the referenced specification and furnished by the Contractor at the Contractor's expense. The number of the samples and test specimens shall be entirely at the discretion of the Engineer. Unidentified metal products, such as sheet, plate and hardware shall be subject to the requirements of Section 55-1.02A (6), "Unidentified Stock Material" of the Standard Specifications.
- o. When requested by the Engineer, the Contractor shall furnish, without charge, samples of all materials entering into the Work, and no material shall be used prior to approval by the Engineer, except as provided in Section 3-1.04, "Certificates of Compliance." Samples of material from local sources shall be taken by or in the presence of the Engineer; otherwise, such samples will not be considered for testing.

3-1.04 Certificates of Compliance.

- a. Certificates of Compliance shall be furnished prior to the use of any materials for which the Technical Specifications require that a certificate be furnished. In addition, when so authorized in the Technical Specifications, the Engineer may permit the use of certain materials or assemblies prior to sampling and testing if accompanied by a Certificate of Compliance. The certificate shall be signed by the manufacturer of the material or the manufacturer of assembled materials and shall state that the materials involved comply in all respects with the requirements of the Technical Specifications. A Certificate of Compliance shall be furnished with each lot of material delivered to the work and the lot so certified shall be clearly identified in the certificate.
- b. Materials used on the basis of a Certificate of Compliance may be sampled and tested at any time. The fact that material is used on the basis of a Certificate of Compliance shall not relieve the Contractor of responsibility for incorporating material in the Work which conforms to the requirements of the Project Plans and Technical Specifications, and any material not conforming to the requirements will be subject to rejection whether in place or not.
- c. The District reserves the right to refuse to permit the use of material on the basis of a Certificate of Compliance.
- d. The form of the Certificate of Compliance and its disposition shall be as directed by the Engineer.

3-1.05 Samples Furnished by the Contractor. The Contractor must furnish all samples for approval as directed in sufficient time to permit the Designer or Engineer to examine, approve and select samples before they are required by the progress of the Work. Portions of the Work for which samples are required and for which the Designer or Engineer has selected samples must be in accordance with such approved samples. Samples must be sent prepaid to the office of the Engineer or to such place as the Engineer may direct.

3-1.06 Materials and Substitutions.

- a. Materials used for the Work must be new and of the quality specified. When not particularly specified, materials must be the best of their class or kind. The Contractor must, if required, submit satisfactory evidence as to the kind and quality of materials.
- b. If the Contractor submitted complete information to the District for products proposed as equals in accordance with the bid package, and the District approved such products proposed as equals in writing, the Contractor may either furnish such products approved as equals, or furnish the products listed by manufacturer name, brand or model number in the Technical Specifications

or Project Plans. The District retains the right, in its sole discretion, to accept or reject any other proposed substitution. To be considered, proposals concerning products proposed as equals must include sufficient information to permit the District to determine whether the products proposed as equals will satisfy the same performance requirements as products listed by manufacturer's name, brand or model number. Such performance requirements may include, but are not limited to, size, strength, function, appearance, ease of maintenance and repair, and useful life requirements. If the District does not accept a proposed substitution, the Contractor must furnish the product specified in the Technical Specifications or Project Plans for the Contract Price, regardless of whether the product is specified by manufacturer's name, brand or model number, or otherwise.

3-1.07 Contractors Responsibility For The Work And Materials.

- a. Until the acceptance of the Work, the Contractor shall have the charge and care of the Work and of the materials to be used and shall bear the risk of injury, loss or damage to any part thereof by the action of the elements or from any other cause, whether arising from the execution or from the non-execution of the Work, except as provided in Sections 6-1.16, "Public Convenience," and 5-1.11, "Relief From Maintenance and Responsibility." The Contractor shall rebuild, repair, restore, and make good all injuries, losses or damages to any portion of the Work or the materials occasioned by any cause before its completion and acceptance and shall bear the expense thereof, except for those injuries, losses, or damages that are directly and proximately caused by acts of the Federal Government or the public enemy. Where necessary to protect the Work or materials from damage, the Contractor shall, at the Contractor's expense, provide suitable drainage of the roadway and erect those temporary structures that are necessary to protect the Work or materials from damage. The suspension of the Work from any cause whatever shall not relieve the Contractor of the responsibility for the Work and materials as herein specified. If ordered by the Engineer, the Contractor shall, at the Contractor's expense, properly store materials which have been partially paid for by the District or which have been furnished by the District. Storage by the Contractor shall be on behalf of the District and the District shall at all times be entitled to the possession of the materials, and the Contractor shall promptly return the materials to the site of the Work when requested. The Contractor shall not dispose of any of the materials so stored except on written authorization from the Engineer.
- b. During the performance of the Work, all materials must be neatly stacked, properly protected from the weather and other adverse impacts, and placed so as to avoid interference with efficient progress of the Work, with other activities of the District, or with the use of existing District facilities by the public. All materials must be delivered so as to ensure efficient and uninterrupted progress of the Work. Materials must be stored so as to cause no obstruction and so as

to prevent overloading of any portion of the Work. The Contractor will be responsible for damage or loss of materials delivered to and/or stored at the Work site due to weather or other causes. The Contractor must promptly remove from the Work site all materials rejected by the District or its representatives as failing to conform to the requirements of the Contract Documents, whether such non-conforming materials have been incorporated in the Work or not. If the District or its representatives so direct, the Contractor must promptly replace and re-execute Work performed by the Contractor and order the replacement and re-execution of Work performed by subcontractors using non-conforming materials with materials that satisfy the requirements of the Contract Documents without expense to the District. The Contractor will bear the expense of making good all Work destroyed or damaged by such removal. The Contractor will have all of the obligations and the District will have all of the rights and remedies that are specified in Section 9 concerning any failure by the Contractor to replace or re-execute Work using non-conforming materials, and/or to make good all work destroyed or damaged by such removal and/or execution.

3-1.08 Audit and Examination of Records. The District may examine and audit at no additional cost to the District all books, estimates, records, contracts, documents, bid documents, bid cost data, subcontract job cost reports and other Project related data of the Contractor, subcontractors engaged in performance of the Work, and suppliers providing supplies, equipment and other materials required for the Work, including computations and projections related to bidding, negotiating, pricing or performing the Work or contract modifications and other materials concerning the Work, including, but not limited to, Contractor daily logs, in order to evaluate the accuracy, completeness, and currency of cost, pricing, scheduling and any other project related data. The Contractor will make available all such Project related data at all reasonable times for examination, audit, or reproduction at the Contractor's business office at or near the Work site, and at any other location where such Project related data may be kept until three years after final payment under the Agreement. Pursuant to California Government Code Section 8546.7, if the amount of public funds to be expended is in excess of \$10,000, this Agreement shall be subject to the examination and audit of the State Auditor, at the request of the District, or as part of any audit of the District, for a period of three (3) years after final payment under the Agreement.

3-1.09 Advertising. No advertising signs of any kind may be displayed on the Work site, or on fences, offices or elsewhere adjacent to the Work site.

3-1.10 Project Schedule. Within 7 days of issuance of the Notice to Proceed, the Contractor must submit a schedule showing each task of Work, the sequence of each task, the number of days required to complete each task, and the critical path controlling the completion of the entire Work. The schedule must allow for the completion of the entire Work within the Time for Completion.

- a. District Review of Schedule. The District may review the Contractor's submitted schedule and may note any exceptions. The Contractor must correct any exceptions noted by the District within five (5) working days of being notified of the exceptions.
- b. Update of Schedule. After submission of a schedule to which the District has taken no exceptions, the Contractor must submit an updated schedule on a biweekly basis or as otherwise specified by the District until completion of the Work. The updated schedule must show the progress of Work as of the date specified in the updated schedule.
- c. Float. The schedule shall show early and late completion dates for each task. The number of days between these dates will be designated as "float". The Float will be designated to the Project and will be available to both the District and the Contractor as needed.
- d. Failure to Submit Schedule. If the Contractor fails to submit schedules within the time periods specified in this Section, or submit a schedule to which the District has taken uncorrected exceptions, the District may withhold payments to the Contractor until such schedules are submitted and/or corrected in accordance with the Contract Documents.
- e. Responsibility for Schedule. The Contractor will be solely and exclusively responsible for creating the schedule and properly updating it. The District may note exceptions to any schedule submitted by the Contractor. However, if the Contractor will be solely responsible for determining the proper method for addressing such exceptions and the District's review of the schedule will not place scheduling obligation on the District.

3-1.11 Construction Staking. Where the Contract Documents require, the Contractor shall employ a licensed Land Surveyor to perform construction staking. Stakes and marks will be set by the Surveyor as the Engineer determines to be necessary to establish the lines and grades required for the completion of the Work.

- a. The Contractor will be responsible for coordinating performance of the Work with the Surveyor and for all costs associated with construction staking and layout.
- b. Contractor shall provide "cutsheets" for the Engineer to review and use in checking grades. Finished grades shall be within 0.01 feet in elevation and 0.03 feet horizontal layout.
- c. Full compensation for Construction Staking shall be considered as included in the prices paid for the various items of Work involved, and no additional allowance will be made therefore.

3-1.12 Detours.

- a. The Contractor shall construct and remove detours and detour bridges for the use of public traffic as provided in the Special Provisions, or as shown on the Project plans or as directed by the Engineer. Payment for this Work will be made as set forth in the Special Provisions or at the contract prices for the items of Work involved
- b. The cost of repairing damage to detours caused by public traffic will be paid for as provided in this Section 3.
- c. When public traffic is routed through the Work, provision for a passageway through construction operations will not be considered as detour construction or detour maintenance, and this Work shall conform to and be paid for as provided in Section 6-1.16, "Public Convenience" unless otherwise specified in the Special Provisions.
- d. Detours used exclusively by the Contractor for hauling materials and equipment shall be constructed and maintained by the Contractor at the Contractor's expense.
- e. The failure or refusal of the Contractor to construct and maintain detours at the proper time shall be sufficient cause for suspending the Work until the detours are in satisfactory condition for use by public traffic.
- f. Where the Contractor's hauling is causing such damage to the detour that its maintenance in a condition satisfactory for public traffic is made difficult and unusually expensive, the Engineer shall have authority to regulate the Contractor's hauling over the detour.

3-1.13 District Directed Change Orders. The District may at any time during the progress of the Work direct any amendments to the Work or any of the Contract Documents, including, but not limited to the Technical Specifications, or Project Plans. Such amendments will in no way void the agreement, but will be applied to amend the Contract Price, if such amendments affect the Contract Price, the Project schedule, if such amendments affect the Project schedule, or any other provision of the Contract Documents based on a fair and reasonable valuation of the amendment in accordance with this Section 3.

3-1.14 Writing Requirement. Change orders and other amendments to the Technical Specifications, the Project Plans, or other Contract Documents may be made only by a writing executed by authorized representatives of the District and the Contractor.

3-1.15 Contractor Proposed Change Orders. Unless the Engineer otherwise authorizes or the District and the Contractor otherwise agree, change order proposals submitted by the Contractor must be submitted to the Engineer no later than the time of the proposed change. The Project Manager shall review the proposed change order and respond by acknowledging the contract change, supplying information and not acknowledging a change order, or recommending other action. If the Project Manager acknowledges the contract change, the Contractor shall submit a change order to the Project Manager as set forth in this Section. Each change order submitted by the Contractor shall be accompanied by the following certification executed by an officer of Contractor:

I, _____, being the _____ of _____ (Contractor), declare under penalty of perjury under the laws of the State of California, and do personally certify and attest that: I have thoroughly reviewed the attached request for change order and know its contents, and said request for change order is made in good faith; that it is supported by truthful and accurate data; that the amount requested and the additional time requested accurately reflects the allowable expenses that would be incurred, and the time necessary, to perform the change order; and further, that I am familiar with California Penal Code section 72 and California Government Code section 12650, et seq., pertaining to false claims, and further know and understand that submission or certification of a false claim may lead to fines, imprisonment, or other severe legal consequences.

3-1.16 All Change Orders. All proposed change orders must be submitted on completed Change Order forms provided in the Contract Documents. All such proposed change orders must itemize all cost impacts of the proposed change order and include a total price for that change order and the amended Contract Price that would become effective upon execution of the change order. All proposed change orders must specify any change in the Project schedule, or in any project milestone including, but not limited to, the Time for Completion, under the change order. It is understood that change orders that do not specify a change in any milestone, including, but not limited to, the Time for Completion, must be accomplished by the Time for Completion then in effect.

3-1.17 Change Order Pricing. Change order pricing for all change orders, whether, additive, deductive, or both, will be governed by the following:

- a. Prices specified in the Contract Documents will apply to cost impacts involving items for which the Contract Documents specify prices.
- b. Cost impacts involving items for which the Contract Documents do not specify prices may be paid on a lump sum basis as approved by the District.
- c. For cost impacts involving items for which the Contract Documents do not specify prices, and for which no lump sum amount has been approved by the

District, charges or credits for the Work will be paid on a time and materials basis in accordance with the following and subject to Caltrans Standard Specifications, provision 9-1.03, concerning allowable direct charges. The time and materials payment will be the sum of and limited to the direct and indirect costs for labor, materials, equipment and overhead calculated as follows:

1. Labor: The Contractor will be paid the cost of labor for the workers (including foremen when authorized by the Engineer), used in the actual and direct performance of the Work. The cost of labor utilized in performing the Work, whether the employer is the Contractor, a subcontractor or other entity engaged in the performance of the Work, will be the sum of the following:
 - Actual Wages: The actual wages paid will include any employer fringe benefit payments to or on behalf of the workers for health and welfare, pension, vacation and similar purposes. The actual wages and fringe benefits paid must be at the rates shown on the certified payroll documents submitted by the Contractor.
 - Labor Surcharge: The labor surcharge will be as set forth in the latest edition of the California Department of Transportation publication entitled "Labor Surcharge and Equipment Rental Rates". The labor surcharge will constitute full compensation for all payments imposed by State or Federal laws and for all other payments made to, or on behalf of, workers engaged in the performance of the Work, excluding the Actual Wages as defined above.
 - Fixed Markup: A fixed markup of 15% of the sum of the actual wages paid and the labor surcharge applicable to such actual wages, together with the actual wage and labor surcharge costs described in this provision will constitute full and complete compensation for all overhead, profit, incidentals, and any and all other direct or indirect expenses associated with furnishing all labor for the Work.
2. Materials: Materials costs will be the direct costs for materials actually exhausted, consumed or entering permanently into the Work, plus a fixed markup of 15% of such direct materials costs, which, together with the direct cost of materials as described in this provision will constitute full and complete compensation for all overhead, profit, incidentals, and any and all other direct or indirect expenses associated with furnishing all materials for the Work.
3. Equipment: All equipment used will be paid in accordance with the rates in subsection 9-1.04D (3) entitled "Equipment Rental" of the Standard

Specifications, plus a fixed markup of 10% of such equipment rates, which, together with the equipment rates as described in this provision will constitute full and complete compensation for all overhead, profit, incidentals, and any and all other direct or indirect expenses associated with furnishing all equipment for the Work.

4. Unless approved in writing in accordance with provision 3-1.14 of this Contract in advance of performance of the Work, any and all other cost impacts (including, but not limited to profit, bond premiums or fees, insurance premiums or fees, superintendent labor, clerical expenses, home office expenses, Work site office expenses, utility costs, permit costs, and licensing costs) involving items for which the Contract Documents do not specify prices, and for which no lump sum amount has been approved by the District, will constitute incidentals, full compensation for which will be deemed included in the markups for labor, material, and equipment specified above, and no additional compensation for such cost impacts will be allowed.

3-1.18 Liability Under Unapproved Change Orders. The Contractor will be solely responsible for any and all losses, costs, or liabilities of any kind incurred by the Contractor, any subcontractor engaged in the performance of the Work, any party supplying material or equipment for the Work or any third party that are incurred pursuant to Contractor-proposed change orders prior to issuance of an approved change order executed in accordance with this Section 3. The Contractor will have all of the obligations and the District will have all of the rights and remedies that are specified in Section 9 concerning any work or resulting losses, costs, or liabilities pursuant to a Contractor proposed change order before issuance of an approved change order executed in accordance with this Section 3.

3-1.19 Changes Subject to Contract Documents. Any changes in the Work and/or the Contract Documents pursuant to change orders and any other amendments issued in accordance with the Contract Documents, including this Section 3, will in all respects be subject to all provisions of the Contract Documents, including, but not limited to, the Technical Specifications and the Project Plans, except as modified by such change orders or amendments.

3-1.20 Change Order Disputes.

- a. Disputed District Directed Change Orders. If the Contractor disputes a District directed change order following a reasonable effort by the and the Contractor to resolve the dispute including, at a minimum, a meeting between appropriate representatives of the Contractor and the District, the Contractor must commence performing the Work consistent with the disputed change order within five (5) working days of the last meeting between representatives of the Contractor and the District to resolve the dispute, or within the time specified in the disputed District directed change order, whichever is later. In performing Work consistent with a disputed District-directed change order pursuant to this

provision the Contractor will have all of the Contractor's rights concerning claims pursuant to the Contract Documents and applicable law.

- b. Disputed Contractor Proposed Change Orders. If the District disputes a Contractor proposed change order, the District and the Contractor will use reasonable efforts to resolve the dispute including, at a minimum, holding a meeting between appropriate representatives of the Contractor and the District. Regardless of and throughout any such efforts to resolve the dispute the Contractor must continue performing the Work irrespective of and unmodified by the disputed change order. In continuing to perform the Work, the Contractor will retain all of the Contractor's rights under contract or law pertaining to resolution of disputes and protests between contracting parties. Disputes between the District and the Contractor concerning any Contractor-proposed change order or other amendment do not excuse the Contractor's obligation to perform the Work in accordance with the Contract Documents excluding such Contractor-proposed change order or other amendment by the Time for Completion or waive any other Project milestone or other requirement of the Contract Documents.

**SECTION 4
TRENCHING AND UTILITIES
AND
PROJECT FACILITIES**

4-1.01 The Construction Safety Orders of the Division of Occupational Safety and Health shall apply to all excavations.

- a. Detailed plans of protective systems for which the Construction Safety Orders require design by a registered professional engineer shall be prepared and signed by an engineer who is registered as a Civil Engineer in the State of California, and shall include the soil classification, soil properties, soil design calculations that demonstrate adequate stability of the protective system, and any other design calculations used in the preparation of the plan.
- b. No plan shall allow the use of a protective system less effective than that required by the Construction Safety Orders.
- c. If the detailed plan includes designs of protective systems developed only from the allowable configurations and slopes, or Appendices, contained in the Construction Safety Orders, the plan shall be submitted at least 5 days before the Contractor intends to begin excavation. If the detailed plan includes designs of protective systems developed from tabulated data, or designs for which design by a registered professional engineer is required, the plan shall be submitted at least 3 weeks before the Contractor intends to begin excavation.

4-1.02 Excavation More Than Four Feet Deep. In accordance with California Public Contract Code Section 7104, if the Work involves excavation more than four feet deep the Contractor must promptly notify the District in writing before disturbing: any material that the Contractor believes may be hazardous waste, as defined in Section 25117 of the Health and Safety Code, that is required to be removed to a Class I, Class II or Class III disposal site in accordance with provisions of existing law; any subsurface or latent physical conditions at the Work site differing from those indicated; or any unknown physical conditions at the Work site of any unusual nature, different materially from those ordinarily encountered and generally recognized as inherent in work of the character provided for in the Contract Documents. The District will promptly investigate any such conditions for which notice is given. If the District finds that the conditions do materially differ, or involve hazardous waste, and would cause a decrease or increase in the cost or time of performance of the Work, the District will issue a change order pursuant to Section 3 of these General Provisions. If a dispute arises between the District and the Contractor concerning whether the conditions materially differ, or involve hazardous waste, or cause a decrease of increase in the cost or time of performance, the Contractor will not be excused from any completion date provided in the Contract Documents, but shall proceed with all Work to be performed. The

Contractor will retain all rights under contract or law pertaining to resolution of disputes and protests between contracting parties.

4-1.03 Excavation of Five Feet or More. In accordance with California Labor Code Section 6705, contractors performing contracts exceeding \$25,000 in cost and involving excavation five or more feet deep must submit for the District's acceptance, prior to excavation, a detailed plan showing the design of shoring, bracing, sloping, or other provisions to be made for worker protection from the hazard of caving ground during excavation. The detailed plan shall include any tabulated data and any design calculations used in the preparation of the plan. Excavation shall not begin until the detail plan has been reviewed and approved. If the plan varies from the shoring system standards, it must be prepared by a registered civil or structural engineer.

4.1.04 Utility Relocation Costs.

- a. In accordance with California Government Code Section 4215, the District assumes the responsibility for the timely removal, relocation or protection of existing main or trunkline utility facilities located on the Work site if such utilities are not identified by the District in the Technical Specifications and/or Project Plans. The District will compensate the Contractor for the costs of locating, repairing damage not due to the Contractor's failure to exercise reasonable care, and removing or relocating existing main or trunkline utility facilities located at the Work site and not identified with reasonable accuracy in the Technical Specifications and/or Project Plans. The District will also compensate the Contractor for the cost of equipment on the Project necessarily idled during such work. The Contractor will not be assessed liquidated damages for Work completion delays caused by the District's failure to provide for removal or relocation of such main or trunkline utility facilities.
- b. Nothing in this provision or the Contract Documents will be deemed to require the District to indicate the presence of existing service laterals or appurtenances whenever the presence of such utilities on the Work site can be inferred from the presence of other visible facilities, such as buildings, meter and junction boxes, on or adjacent to the Work site; provided, however, that nothing in this provision or the Contract Documents shall relieve the District from identifying main or trunklines in the Technical Specifications and/or Project Plans.
- c. Nothing in this provision or the Contract Documents will preclude the District from pursuing any appropriate remedy against the utility for delays which are the responsibility of the utility.
- d. Nothing in this provision or the Contract Documents will be construed to relieve the utility from any obligation as required either by law or by contract to pay the cost of removal or relocation of existing utility facilities.

- e. If the Contractor while performing the Work discovers utility facilities not identified by the District in the Technical Specifications and/or Project Plans, the Contractor must immediately notify the District and utility in writing.
- f. Either the District or the utility, whichever owns existing main or trunkline utility facilities located on the Work site, shall have sole discretion to effect repairs or relocation work or to permit the Contractor to perform such repairs or relocation work at a reasonable price.

4-1.05 Utility and Non-Highway Facilities

- a. The Contractor shall protect from damage utility and other non-highway facilities that are to remain in place, be installed, relocated or otherwise rearranged.
- b. It is anticipated that some or all of the utility and other non-highway facilities, both above ground and below ground, that are required to be rearranged (as used herein, rearrangement includes installation, relocation, alteration or removal) as a part of the highway improvements comprising part of the Work will be rearranged in advance of construction operations. Where it is not anticipated that the rearrangement will be performed prior to construction, or where the rearrangement must be coordinated with the Contractor's construction operations, the existing facilities that are to be rearranged will be indicated on the Project Plans or in the Special Provisions. Where a rearrangement is indicated on the Project Plans or in the Special Provisions, the Contractor will have no liability for the costs of performing the work involved in the rearrangement.
- c. The right is reserved to the District and the owners of facilities, or their authorized agents, to enter upon the highway right of way for the purpose of making those changes that are necessary for the rearrangement of their facilities or for making necessary connections or repairs to their properties. The Contractor shall cooperate with forces engaged in this Work and shall conduct operations in such a manner as to avoid any unnecessary delay or hindrance to the Work being performed by the other forces. Wherever necessary, the work of the Contractor shall be coordinated with the rearrangement of utility or other non-highway facilities, and the Contractor shall make arrangements with the owner of those facilities for the coordination of the Work.
- d. Attention is directed to the possible existence of underground main or trunk line facilities not indicated on the Project Plans or in the Special Provisions and to the possibility that underground main or trunk lines may be in a location different from that which is indicated on the Project Plans or in the Special Provisions. The Contractor shall ascertain the exact location of underground main or trunk lines whose presence is indicated on the Project Plans or in the

Special Provisions, the location of their service laterals or other appurtenances, and of existing service lateral or appurtenances of any other underground facilities which can be inferred from the presence of visible facilities such as buildings, meters and junction boxes prior to doing Work that may damage any of the facilities or interfere with their service.

- e. If the Contractor cannot locate an underground facility whose presence is indicated on the Project Plans or in the Special Provisions, the Contractor shall so notify the Engineer in writing. If the facility for which the notice is given is in a substantially different location from that indicated on the Project Plans or in the Special Provisions, the additional cost of locating the facility will be paid for as provided in Section 3.
- f. If the Contractor discovers underground main or trunk lines not indicated on the Project Plans or in the Special Provisions, the Contractor shall immediately give the Engineer and the Utility Company written notification of the existence of those facilities. The main or trunk lines shall be located and protected from damage as directed by the Engineer, and the cost of that work will be paid for as extra work as provided in Section 3. The Contractor shall, if directed by the Engineer, repair any damage which may occur to the main or trunk lines. The cost of that repair work, not due to the failure of the Contractor to exercise reasonable care, will be paid for as provided in Section 3. Damage due to the Contractor's failure to exercise reasonable care shall be repaired at the Contractor's cost and expense.
- g. Where it is determined by the Engineer that the rearrangement of an underground facility is essential in order to accommodate the highway improvement and the Project Plans and Technical Specifications do not provide that the facility is to be rearranged, the Engineer will provide for the rearrangement of the facility by other forces or the rearrangement shall be performed by the Contractor and will be paid for as provided in Section 3.
- h. When ordered by the Engineer in writing, the Contractor shall rearrange any utility or other non-highway facility necessary to be rearranged as a part of highway improvements comprising part of the Work, and that Work will be paid for as provided in Section 3.
- i. Should the Contractor desire to have any rearrangement made in any utility facility, or other improvement, for the Contractor's convenience in order to facilitate the Contractor's construction operations, which rearrangement is in addition to, or different from, the rearrangements indicated on the Project Plans or in the Special Provisions, the Contractor shall make whatever arrangements are necessary with the owners of the utility or other non-highway facility for the rearrangement and bear all expenses in connection therewith.

- j. The Contractor shall immediately notify the Engineer of any delays to the Contractor's operations as a direct result of underground main or trunk line facilities which were not indicated on the Project Plans or in the Special Provisions or were located in a position substantially different from that indicated on the Project Plans or in the Special Provisions, or as a direct result of utility or other non-highway facilities not being rearranged as herein provided (other than delays in connection with rearrangement made to facilitate the Contractor's construction operations or delays due to a strike or labor dispute). Compensation for the delay will be determined in conformance with the provisions in Section 3.

4-1.06 Work Site Offices. Any Work site office facilities used by the Contractor and/or its privities must conform to all applicable codes, ordinances and regulations. The cost of such Work site office facilities shall be paid from and included in the Contract Price.

4-1.07 District Rights of Access and Ownership. The District and its authorized representatives will at all reasonable times while such office facilities are located at the Work site (including, at a minimum, all times during which the Work is performed), have access to any such Work site office facilities used by the Contractor and/or its privities. With respect to the right of access of the District and its authorized representatives, neither the Contractor nor its privities shall have a reasonable expectation of privacy pursuant to the Fourth Amendment to the Unites States Constitution or other applicable law concerning such Work site office facilities used by the Contractor and/or its privities. Without exception, any and all Project related materials located at such Work site facilities will be deemed at all times to be District property subject to inspection and copying by the District and its authorized representatives at all reasonable times while such facilities are located at the Work site (including, at a minimum, all times during which the Work is performed). Any interference by the Contractor or its privities with the District's rights of access and/or ownership pursuant to this Section 4 will constitute a material breach of the Agreement subject to any and all remedies available pursuant to the Contract Documents and at law and equity.

SECTION 5

PROSECUTION AND PROGRESS OF THE WORK

5-1.01 Beginning of Work.

- a. The Contractor shall begin Work within 10 calendar days after receiving notice to proceed from the District, and shall diligently prosecute the same to completion within the Time for completion specified in the Agreement.
- b. Should the Contractor begin Work in advance of receiving notice that the Agreement has been approved as above provided, any Work performed by the Contractor in advance of the date of approval shall be considered as having been done by the Contractor at the Contractor's own risk and as a volunteer unless the Agreement is approved.
- c. The delivery to the District for execution and approval of the Agreement properly executed on behalf of the Contractor and surety and provision of all other required documents in accordance with the Agreement shall constitute the Contractor's authority to enter upon the Work site and to begin operations, subject to the Contractor's assumption of the risk of the disapproval of the Agreement, as above provided, and subject also to the following:
 1. The Contractor shall, on commencing operations, take all precautions required for public safety and shall observe all the provisions in the Contract Documents.
 2. In the event of disapproval, the Contractor shall at the Contractor's expense do that work that is necessary to leave the site in a neat condition to the satisfaction of the Engineer. If the Work done affects any existing road or highway, the Contractor shall at the Contractor's expense restore it to its former condition, or the equivalent thereof, to the satisfaction of the Engineer.
 3. All Work done according to the Agreement prior to its approval, will, when the Agreement is approved, be considered authorized Work and will be paid for as provided in the Agreement.
 4. The Contractor shall not be entitled to any additional compensation or an extension of time for any delay, hindrance or interference caused by or attributable to commencement of Work prior to the date on which the Agreement was approved by the District.

5-1.02 Liquidated Damages. Time is of the essence in the Agreement. The District and the Contractor agree that it will be difficult and/or impossible to determine the actual damage which the District will sustain in the event of the Contractor's failure

to fully perform the Work or to fully perform all of the Contractor's obligations that have accrued pursuant to the Agreement by the Time for Completion. Accordingly, the District and the Contractor agree in accordance with California Government Code Section 53069.85 that the Contractor will forfeit and pay to the District liquidated damages in the sum of **\$1,500 per day** for each and every calendar day completion of the Work and/or performance of all of the Contractor's obligations that have accrued pursuant to the Agreement is delayed beyond the Time for Completion. The District and the Contractor further agree in accordance with California Government Code Section 53069.85 that the liquidated damages sum specified in this provision is not manifestly unreasonable under the circumstances existing at the time the Agreement was made, and that the District may deduct liquidated damages sums in accordance with this provision from any payments due or that may become due the Contractor under the Agreement.

5-1.03 No Damage for Delay Beyond District and Contractor Control. The Contractor will not be held responsible for delays in performance of the Work caused by delay beyond the control of both District and Contractor, such as by strikes, lockouts, or labor disturbances that are not within the control of the Contractor to resolve, lack or failure of transportation, or acts of other government entities. This provision will not apply where the delay would not have occurred but for a previous Contractor caused delay in the prosecution of the Work. The District will not be liable to the Contractor, any subcontractor or other entity engaged in the performance of the Work, any supplier, or any other person or organization, or to any surety or employee or agent of any of them, for damages arising out of or resulting from (i) delays beyond the control of the District and the Contractor including but not limited to fires, floods, epidemics, abnormal weather conditions, earthquakes and acts of God or acts or neglect by utility owners or other contractors performing other work, or (ii) delays caused by the District, its officials, officers, employees, agents, or volunteers, or delays caused by the Engineer or the Designer or Engineer, which delays are reasonable under the circumstances involved and/or are within the contemplation of the District and the Contractor. An extension of the Time for Performance in an amount equal to the time loss due to such delay(s) will be the Contractor's sole and exclusive remedy for such delay(s).

5-1.04 No Damage for Contractor Caused Delay. Contractor shall not be entitled to additional compensation for extended field or home office overhead, field supervision, costs of capital, interest, escalation charges, acceleration costs or other impacts for any delays to the extent such delays are caused by the failure of the Contractor or any subcontractor or other entity engaged in performance of the Work to perform the Work in accordance with the Contract Documents. Contractor may be eligible for additional compensation in excess of the Contract Price for delays caused by the District and/or its privities.

5-1.05 No Damage for Other Delay. Contractor will not be entitled to damages for delay to the Work caused by the following, which the District and Contractor agree will be deemed for purposes of California Public Contract Code Section 7102 either not

caused by the District, and/or within the contemplation of the District and the Contractor, and/or reasonable under the circumstances:

- a. Exercise of the District's right to sequence the Work in a manner that would avoid disruption to the District and other contractors based on: the failure of the Contractor or any subcontractor or other entity engaged in the performance of the Work to perform the Work in accordance with the Contract Documents, enforcement by the District or any other governmental agency of competent jurisdiction of any government act or regulation, or enforcement by the District of any provisions of the Agreement.
- b. Requests for clarification or information concerning the Contract Documents or proposed change orders or modifications to the Contract Documents, including extensive and/or numerous such requests for clarification or information or proposed change orders or modifications, provided such clarifications or information or proposed change orders or modifications are processed by the District or its representatives in a reasonable time in accordance with the Contract Documents.

5-1.06 Delays Caused by the District and/or Its Privities. Either the District or the Contractor may propose a change in the Time for Completion for delays that are purported to be caused by the District and/or its privities and that are not reasonable under the circumstances involved and/or that are not within the contemplation of the District and the Contractor. Such proposed changes in the Time for Completion will constitute change order proposals subject to Section 3. In accordance with Section 3, the District and the Contractor may agree upon pricing for the cost impacts, if any, resulting from such delays. If such pricing is in anticipation of cost impacts that may, but have not yet occurred, the District will be obligated to pay the Contractor for such anticipated impacts in accordance with the Agreement and any applicable, approved change orders only to the extent the Contractor actually incurs the anticipated cost impacts. Notwithstanding anything to the contrary in Section 3, the District and the Contractor may agree to a daily rate or cap or lump sum that will apply to the cost impacts, if any, resulting from delay purportedly caused by the District and/or its privities subject to this provision. However, if such daily rate or cap or lump sum is in anticipation of cost impacts that have not yet occurred, the District will be obligated to pay such daily rate or cap or lump sum only to the extent the Contractor actually incurs such cost impacts.

5-1.07 Weather Delays. Extensions of the Time for Completion will not be allowed for weather conditions that are consistent with the historical rain days reflected in historical weather data of the National Oceanographic and Atmospheric Administration (NOAA) of the U.S. Department of Commerce for the record station that is nearest or most applicable to the Work site. Extensions of the Time for Completion for delays due to adverse weather will be allowed only if the number of rain days exceeds those that can be anticipated based on the NOAA data and the Contractor can verify to the District's reasonable satisfaction that such

adverse weather caused actual delay in the timely completion of the Work. No extensions of the Time for Completion will be granted for rain days that exceed those that can be anticipated based on the NOAA data and that merely result in delays that do not or would not, themselves, result in failure to complete the Work by the Time for Completion.

5-1.08 Delay Claims. Whenever the Contractor claims a delay for which the Time for Completion may be extended, the Contractor must request an extension of time within five (5) days of the start of the delay. The request must be in writing and describe in detail the cause for the delay, and, if possible, the foreseeable extent of the delay.

5-1.09 Contractor Coordination of the Work.

- a. The District reserves the right to do other work in connection with or in the vicinity of the Project by contract or otherwise, and Contractor shall at all times conduct the Work so as to impose no hardship on the District, others engaged in the Work or other contractors working at the Work site. The Contractor will adjust, correct and coordinate the Work with the work of others so that no delays result in the Work or other work at or near the Work site.
- b. If any part of the Work depends for proper execution or results upon the work of the District or any other contractor, the Contractor will, before proceeding with such Work, promptly report to the District any apparent discrepancies or defects in such other Work. Failure of the Contractor to promptly report any apparent discrepancy or defect will be deemed an acceptance of the District's or other contractor's Work as fit and proper.
- c. The Contractor will anticipate the relations of the various trades to the progress of the Work and will ensure that required anchorage or blocking is furnished and set at proper times. Anchorage and blocking necessary for each trade shall be part of the Work except where stated otherwise.
- d. The Contractor will provide proper facilities at all times for access of the District, the Engineer, Designer, and other authorized District representatives to conveniently examine and inspect the Work.
- e. Should construction be under way by other forces or by other contractors within or adjacent to the limits of the Work specified or should work of any other nature be under way by other forces within or adjacent to those limits, the Contractor shall cooperate with all the other contractors or other forces to the end that any delay or hindrance to their work will be avoided. The right is reserved to perform other or additional work at or near the site (including material sources) at any time, by the use of other forces.

- f. When 2 or more contractors are employed on related or adjacent work, or obtain materials from the same material source, each shall conduct their operations in such a manner as not to cause any unnecessary delay or hindrance to the other.
- g. Each contractor shall be responsible to the other for all damage to Work, to persons or property caused to the other by their operations, and for loss caused the other due to unnecessary delays or failure to finish the work within the time specified for completion.

5-1.10 Differing Site Conditions.

- a. During the progress of the Work, if subsurface or latent physical conditions are encountered at the site differing materially from those indicated in the Agreement or if unknown physical conditions of an unusual nature, differing materially from those ordinarily encountered and generally recognized as inherent in the Work, are encountered at the site, the Contractor shall promptly notify the District in writing of the specific differing conditions before they are disturbed and before the affected work is performed.
- b. Upon written notification, the Engineer will investigate the conditions, and if the Engineer determines that the conditions materially differ and cause an increase or decrease in the cost or time required for the performance of any Work, an adjustment, excluding loss of anticipated profits, will be made and the Agreement modified in writing accordingly. The Engineer will notify the Contractor of the Engineer's determination whether or not an adjustment of the contract is warranted.
- c. No Agreement adjustment that results in a benefit to the Contractor will be allowed unless the Contractor has provided the written notice required in this Section 5-1.10.
- d. Any Agreement adjustment warranted due to differing site conditions will be made in accordance with the provisions in Section 3, "Changes in Work," except as otherwise provided.

5-1.11 Relief From Maintenance And Responsibility.

- a. Upon the request of the Contractor, the District may relieve the Contractor of the duty of maintaining and protecting certain portions of the Work as described below, which have been completed in all respects in accordance with the requirements of the Agreement and to the satisfaction of the Engineer, and thereafter except with the Contractor's consent, the Contractor will not be required to do further Work thereon. In addition, such action by the District will relieve the Contractor of responsibility for injury or damage to those completed portions of the Work resulting from use by public traffic or from the

action of the elements or from any other cause but not from injury or damage resulting from the Contractor's own operations or from the Contractor's negligence.

- b. However, nothing in this Section 5-1.11 providing for relief from maintenance and responsibility will be construed as relieving the Contractor of full responsibility for making good any defective Work or materials found at any time before the formal written acceptance of the entire Agreement by the District.

SECTION 6

CONTRACTOR RESPONSIBILITIES

6-1.01 Eligibility. By executing the Agreement, the Contractor certifies that the Contractor is not ineligible to perform work on public works projects pursuant to California Labor Code Sections 1777.1 or 1777.7. In accordance with California Public Contract Code Section 6109(a), contractors who are ineligible to perform work on public works projects pursuant to California Labor Code Sections 1777.1 or 1777.7 may neither bid on, be awarded or perform the Work. To the full extent permitted by law the Contractor shall hold harmless and indemnify the District from and against any and all damages, costs, and liability arising from or as a consequence of any violation of Public Contract Code Section 6109.

6-1.02 Supervision of the Work. The Contractor will be solely responsible for the performance of the Work, including portions of the Work to be performed by subcontractors. The Contractor is charged with ensuring that all orders or instructions from the District, Engineer or Designer are disseminated to and followed by all subcontractors engaged in performance of the Work. The Contractor will supervise the Work using the Contractor's best skill and attention. At any time during the progress of the Work, the District, the Engineer, or the Designer may require the Contractor and/or subcontractors engaged in performance of the Work to attend a project meeting and the Contractor will attend, and ensure the attendance of any subcontractors whose attendance is required by the District and/or advisable in light of the matters to be addressed at the meeting.

6-1.03 Contractor's Superintendent. The Contractor will keep on the Work, throughout its progress, a competent superintendent and any necessary assistants, all satisfactory to the District. The Contractor shall designate in writing before starting Work the superintendent who shall have the authority to represent and act for the Contractor. The authorized representative shall be present at the site of the Work at all times While work is actually in progress. When Work is not in progress and during periods when Work is suspended, arrangements acceptable to the Engineer shall be made for any emergency Work that may be required. Whenever the Contractor or the Contractor's authorized representative is not present on any particular part of the Work where it may be desired to give direction, orders will be given by the Engineer, which shall be received and obeyed by the superintendent or foreman who may have charge of the particular Work in reference to which the orders are given. Any order given by the Engineer, not otherwise required by the specifications to be in writing, will on request of the Contractor, be given or confirmed by the Engineer in writing. The superintendent may not be changed without the consent of the District. The superintendent will represent the Contractor and all directions given by the District to the superintendent will bind the Contractor in accordance with the Agreement. Superintendent time included in Contractor's completed bid schedule and/or in approved change orders, if any, must be included in Contractor's approved overhead rate and may not be charged as a direct cost.

6-1.04 Competent Employees. The Contractor must at all times enforce strict discipline and good order among the Contractor's employees and may not employ on the Work any unfit person or anyone not skilled in the Work assigned, or anyone incompetent or unfit for the duties of that person. When the District determines that a Contractor employee does not satisfy the requirements of this provision, upon notice from the District, the Contractor must ensure that employee performs no further Work and is no longer present at the Work site. Any such Contractor employee may not again be employed on the Work without District approval. If any subcontractor or person employed by the Contractor shall appear to the Engineer to be incompetent or to act in a disorderly or improper manner, they shall be discharged immediately on the request of the Engineer, and that person shall not again be employed on the work.

6-1.05 Items Necessary for Proper Completion of the Work. Except as otherwise noted in the Contract Documents, the Contractor will provide and pay for all labor, materials, equipment, permits, fees, licenses, facilities and services necessary for the proper execution and timely completion of the Work in accordance with the Contract Documents.

6-1.06 Construction Reports. The Contractor must submit daily construction logs detailing the daily progress of the Work to the Engineer on a weekly basis.

6-1.07 Subcontracting.

- a. By executing the Agreement, the Contractor certifies that no subcontractor included on the list of proposed subcontractors submitted with the Contractor's bid is ineligible to perform work on public works projects pursuant to California Labor Code Sections 1777.1 or 1777.7. In accordance with California Public Contract Code Section 6109(a), subcontractors who are ineligible to perform work on public works projects pursuant to California Labor Code Sections 1777.1 or 1777.7 may neither bid on, be awarded or perform as a subcontractor on the Work. In accordance with California Public Contract Code Section 6109(b), any contract on a public works project entered into between a contractor and a debarred subcontractor is void as a matter of law. The Contractor will ensure that no debarred subcontractor receives any public money for performing the Work, and any public money that may have been paid to a debarred subcontractor for the Work is returned to the District. The Contractor will be responsible for payment of wages to workers of a debarred subcontractor who has been allowed to perform the Work.
- b. The Agreement and the performance of the Work are subject to the requirements of the Subletting and Subcontracting Fair Practices Act codified at California Public Contract Code Section 4100 and following. If the Contractor fails to specify a subcontractor or specifies more than one subcontractor for the same portion of the Work in excess of one-half of 1

percent of the Contractor's total bid, the Contractor agrees that the Contractor is fully qualified to perform that portion of the Work with the Contractor's own forces, and that the Contractor will perform that portion of the Work with the Contractor's own forces. If after award of the Agreement the Contractor subcontracts, except as provided for in California Public Contract Code Sections 4107 or 4109, any such portion of the Work, the Contractor will be subject to the penalties set forth in California Public Contract Code Sections 4110 and 4111, including cancellation of the Agreement, assessment of a penalty of up to 10 percent of the amount of the subcontract, and disciplinary action by the Contractors State License Board.

- c. No contractual relationship exists between the District and any subcontractor engaged in performance of the Work.
- d. Incorporation of Contract Documents. The Contractor must incorporate the Contract Documents in each contract with a subcontractor engaged in the performance of the Work. The Contractor will be solely responsible for any delay or additional costs incurred as a result of its failure to provide adequate or accurate project information to a subcontractor that results in improper submittals and/or work, or time or other impacts is the sole responsibility of the Contractor. The Contractor will have all of the obligations and the District will have all of the remedies that are specified in Section 9 concerning any subcontracted work. Subcontracts shall also contain certification by the subcontractor that the subcontractor is experienced in and qualified to do, and knowledgeable about, the subcontracted Work. Copies of subcontracts shall be available to the Engineer upon written request, and shall be provided to the Engineer at the time any litigation against the District concerning the project is filed.
- e. Coordination of Subcontract Work: The Contractor is responsible for scheduling the Work of subcontractors so as to avoid delay or injury to either Work or materials.
- f. The Contractor shall give personal attention to the fulfillment of the contract and shall keep the work under the Contractor's control.
- g. The Contractor shall perform, with the Contractor's own organization, contract work amounting to not less than 50 percent of the original total contract price, except that any designated "Specialty Items" may be performed by subcontract and the amount of any designated "Specialty Items" performed by subcontract may be deducted from the original total contract price before computing the amount of Work required to be performed by the Contractor with the Contractor's own organization. When items of work in the Engineer's Estimate are preceded by the letters (S) or (S-F), those items are designated as "Specialty Items." Where an entire item is subcontracted, the value of Work subcontracted will be based on the Agreement item bid price. When a portion of an item is

subcontracted, the value of Work subcontracted will be based on the estimated percentage of the Agreement item bid price, determined from information submitted by the Contractor, subject to approval by the Engineer.

- h. Before work is started on a subcontract, the Contractor shall file with the Engineer a written statement showing the work to be subcontracted, the names of the subcontractors and the description of each portion of the Work to be subcontracted.
- i. Pursuant to the provisions of Section 6109 of the Public Contract Code, the Contractor shall not perform Work on a public works project with a subcontractor who is ineligible to perform Work on the public works project pursuant to Section 1777.1 or 1777.7 of the Labor Code.
- j. When a portion of the Work which has been subcontracted by the Contractor is not being prosecuted in a manner satisfactory to the District, the subcontractor shall be removed immediately on the request of the District and shall not again be employed on the Work.
- k. The roadside production of materials produced by other than the Contractor's forces shall be considered as subcontracted. Roadside production of materials shall be construed to be production of aggregates of all kinds with portable, semiportable or temporary crushing or screening, proportioning and mixing plants established or reopened for the purpose of supplying aggregate or material for a particular project or projects. The erection, establishment or reopening of the plants and the operation thereof in the production of materials for use on the Work shall conform to the requirements relating to labor set forth in these General Provisions and in the Special Provisions.

6-1.08 Insurance.

Contractor shall procure and maintain for the duration of the contract insurance against claims for injuries to persons or damages to property which may arise from or in connection with the performance of the work hereunder by the Contractor, his agents, representatives, employees or subcontractors.

- a. All required insurance shall be provided in the form of “occurrence”-type policies underwritten by admitted insurers in the State of California with a rating of A:VII or better from the current year Best Rating Guide. All policies must be issued at the expense of the Contractor and must be maintained at the Contractor’s expense throughout the performance of the Work.
- b. The Contractor and any subcontractors engaged in performance of the Work must secure payment of workers compensation in accordance with California

Labor Code Section 3700 and other applicable law. The Contractor must verify that all Subcontractors comply with this requirement.

- c. Within ten working days following notice of award the Contractor must submit to the Agency along with executed copies of all other documents specified in the Contract Check List certificates of insurance and endorsements evidencing that the Contractor has in effect and will maintain throughout the performance of the Work the following kinds and amounts of insurance against claims for injuries to persons or damages to property which may arise from or in connection with the performance of the work hereunder by the Contractor, his agents, representatives, employees or subcontractors:

Minimum Scope of Insurance

Coverage shall be at least as broad as:

1. Insurance Services Office Commercial General Liability coverage (occurrence form CG 0001).
2. Insurance Services Office form number CA 0001 (Ed. 1/87) covering Automobile Liability, code 1 (any auto).
3. Workers' Compensation insurance as required by the State of California and Employer's Liability Insurance.
4. **Coverage shall not extend to any indemnity coverage for the active negligence of the additional insured in any case where an agreement to indemnify the additional insurance would be invalid under Subsection (b) of Section 2782 of the Civil Code.**

Minimum Limits of Insurance

Contractor shall maintain limits no less than:

1. General Liability: \$2,000,000 per occurrence for bodily injury, personal injury and property damage **including operations, products and completed operations**. If Commercial General Liability Insurance or other form with a general aggregate limit is used, either the general aggregate limit shall apply separately to this project/location or the general aggregate limit shall be twice the required occurrence limit.
2. Automobile Liability: \$2,000,000 per accident for bodily injury and property damage.
3. Employer's Liability: \$1,000,000 per accident for bodily injury or disease.

Deductibles and Self-Insured Retentions

Any deductibles or self-insured retentions must be declared to and approved by the District. At the option of the District, either: the insurer shall reduce or eliminate such deductibles or self-insured retentions as respects the District, its officers, officials, employees and volunteers; or the Contractor shall provide a financial guarantee satisfactory to the District guaranteeing payment of losses and related investigations, claim administration and defense expenses.

Other Insurance Provisions

The general liability and automobile liability policies are to contain, or be endorsed to contain, the following provisions:

1. The District, its officers, officials, employees, and volunteers are to be covered as additional insureds with respect to liability arising out of automobiles owned, leased, hired or borrowed by or on behalf of the contractor; and with respect to liability arising out of work or operations performed by or on behalf of the Contractor including materials, parts or equipment furnished in connection with such work or operations. General and auto liability coverage can be provided in the form of an endorsement to the Contractor's insurance, or as a separate owner's policy.
2. For any claims related to this project, the Contractor's insurance coverage shall be primary insurance as respects the District, its officers, officials, employees, and volunteers. Any insurance or self-insurance maintained by the District, its officers, officials, employees, or volunteers shall be excess of the Contractor's insurance and shall not contribute with it.
3. Each insurance policy required by this clause shall be endorsed to state that coverage shall not be canceled by either party, except after thirty (30) days' prior written notice by certified mail, return receipt requested, has been given to the District.
4. **Coverage shall not extend to any indemnity coverage for the active negligence of the additional insured in any case where an agreement to indemnify the additional insured would be invalid under Subsection (b) of Section 2782 of the Civil Code.**

Waiver of Subrogation

The worker's compensation policy is to be endorsed with a waiver of subrogation. The insurance company, in its endorsement, agrees to waive all rights against the District, its officers, officials, employees and volunteers for losses paid under the terms of this policy which arise from the work performed by the named insured for the District.

Verification of Coverage

Contractor shall furnish the District with original certificates and amendatory endorsements as approved by the District effecting coverage required by this clause. The endorsements should be on forms provided by the District or on other than the District's forms, provided those endorsements or policies conform to the requirements. All certificates and endorsements are to be received and approved by the District before work commences. The District reserves the right to require complete, certified copies of all required insurance policies, including endorsements affecting the coverage required by these specifications at any time.

Subcontractors

Contractor shall include all subcontractors as insureds under its policies or shall furnish separate certificates and endorsements for each subcontractor. All coverage's for subcontractors shall be subject to all of the requirements stated herein.

- d. For each insurance policy required under the Agreement (except for the required workers compensation insurance policy) the Contractor must provide endorsements that add the District, its officers, officials, employees and volunteers as an additional insured. Such endorsements must: provide that the insurance required to be furnished by the Contractor will be primary as regards the Agency, and that the Agency's insurance will be excess of and not contribute to the insurance required to be furnished by the Contractor; that the Agency will receive 30 day written notice of any reduction or cancellation of such insurance required to be furnished by the Contractor; and include a severability of interest clause acceptable to the Agency. Said endorsement shall be at least as broad as Insurance Services Office form number CG2010 (Ed. 11/85).

6-1.09 Indemnities.

- a. The Contractor will take all responsibility for the Work, and will bear all losses and damages directly or indirectly resulting to the Contractor, any subcontractors engaged in performance of the Work, the District, its officials, officers, employees, agents, volunteers and consultants, and to third parties on account of the performance or character of the Work, unforeseen difficulties, accidents, or occurrences of other causes predicated on active or passive negligence of the Contractor or of any subcontractor engaged in performance of the Work. To the fullest extent permitted by law the Contractor will indemnify, defend and hold harmless the District, its officials, officers, employees, agents, volunteers and consultants from and against any or all loss, liability, expense, claims, costs (including costs of defense), suits, and damages of every kind, nature and description (including, but not limited to, penalties resulting from exposure to hazards in violation of the California Labor Code) directly or indirectly arising from the performance of the Work ("Claims").
- b. The Contractor will indemnify, defend and hold harmless the District, the District's officials, officers, employees, volunteers, agents and the Engineer and Designer for all liability on account of any patent rights, copyrights, trade names or other intellectual property rights that may apply to the Contractor's performance of the Work. The Contractor will pay all royalties or other charges as a result of intellectual property rights that may apply to methods, types of construction, processes, materials, or equipment used in the performance of the Work, and will furnish written assurance satisfactory to the District that any such charges have been paid.

- c. The Contractor assumes all liability for any accident or accidents resulting to any person or property as a result of inadequate protective devices for the prevention of accidents in connection with the performance of the Work. The Contractor will indemnify, defend, and hold harmless the District and its officials, officers, employees, agents, volunteers and consultants from such liability.
- d. Approval of the Contractor's certificates of insurance and/or endorsements does not relieve the Contractor of liability under Sections 6-1.08 or 6-1.09. The Contractor will defend, with legal counsel reasonably acceptable to the District, any action or actions filed in connection with any Claims and will pay all related costs and expenses, including attorney's fees incurred. The Contractor will promptly pay any judgment rendered against the District, its officials, officers, employees, agents, volunteers or consultants for any Claims. In the event the District, its officials, officers, employees, agents, volunteers or consultants is made a party to any action or proceeding filed or prosecuted against Contractor for any Claims, Contractor agrees to pay the District, its officials, officers, employees, agents, volunteers and consultants any and all costs and expenses incurred in such action or proceeding, including but not limited to, reasonable attorneys' fees.
- e. In accordance with California Civil Code Section 2782(a), nothing in the Agreement will be construed to indemnify the District for its sole negligence, willful misconduct, or for defects in design furnished by District. In accordance with California Civil Code Section 2782(b), nothing in the Agreement will be construed to impose on the Contractor or to relieve the District from liability for the District's active negligence. By execution of the Contract Documents the Contractor acknowledges and agrees that the Contractor has read and understands the insurance and indemnity requirements of the Contract Documents, which are material elements of consideration.

6-1.10 Licenses/Permits. The Contractor must, without additional expense to the District, obtain all licenses, permits and other approvals required for the performance of the Work.

6-1.11 California Labor Code Requirements.

- a. In accordance with California Labor Code Section 1810, eight (8) hours of labor in performance of the Work shall constitute a legal day's work under the Agreement.
- b. In accordance with California Labor Code Section 1811, the time of service of any worker employed in performance of the Work is limited to eight hours during any one calendar day, and forty hours during any one calendar week, except in accordance with California Labor Code Section 1815, which provides that work in excess of eight hours during any one calendar day and forty hours

during any one calendar week is permitted upon compensation for all hours worked in excess of eight hours during any one calendar day and forty hours during any one calendar week at not less than one-and-one-half times the basic rate of pay.

- c. The Contractor and its subcontractors will forfeit as a penalty to the District \$25 for each worker employed in the performance of the Work for each calendar day during which the worker is required or permitted to work more than eight (8) hours in any one calendar day, or more than forty (40) hours in any one calendar week, in violation of the provisions of California Labor Code Section 1810 et seq.
- d. In accordance with California Labor Code Section 1773.2, the District has determined the general prevailing wages in the locality in which the Work is to be performed for each craft or type of work needed to be as published by the State of California Department of Industrial Relations, Division of Labor Statistics and Research, a copy of which is on file in the office of Coastland Civil Engineering and shall be made available on request. The Contractor and subcontractors engaged in the performance of the Work shall pay no less than these rates to all persons engaged in performance of the Work.
- e. In accordance with California Labor Code Section 1775, the Contractor and any subcontractors engaged in performance of the Work must comply with Labor Code Section 1775, which establishes a penalty of up to \$200 per day for each worker engaged in the performance of the Work that the Contractor or any subcontractor pays less than the specified prevailing wage. The amount of such penalty shall be determined by the Labor Commissioner. The Contractor or subcontractor shall pay the difference between the prevailing wage rates and the amount paid to each worker for each calendar day or portion thereof for which each worker was paid less than the prevailing wage rate. If a subcontractor worker engaged in performance of the Work is not paid the general prevailing per diem wages by the subcontractor, the Contractor is not liable for any penalties therefore unless the Contractor had knowledge of that failure or unless the Contractor fails to comply with all of the following requirements:
 - 1. The contract executed between the Contractor and the subcontractor for the performance of part of the Work must include a copy of the provisions of California Labor Code Sections 1771, 1775, 1776, 1777.5, 1813, and 1815.
 - 2. The Contractor must monitor payment of the specified general prevailing rate of per diem wages by the subcontractor by periodic review of the subcontractor's certified payroll records.

3. Upon becoming aware of a subcontractor's failure to pay the specified prevailing rate of wages, the Contractor must diligently take corrective action to halt or rectify the failure, including, but not limited to, retaining sufficient funds due the subcontractor for performance of the Work.
 4. Prior to making final payment to the subcontractor, the Contractor must obtain an affidavit signed under penalty of perjury from the subcontractor that the subcontractor has paid the specified general prevailing rate of per diem wages employees engaged in the performance of the Work and any amounts due pursuant to California Labor Code Section 1813.
 5. In accordance with California Labor Code Section 1771.4, the project is subject to compliance monitoring and enforcement by the Department of Industrial Relations. In accordance with California Labor Code Section 1776, the Contractor and each subcontractor engaged in performance of the Work, must keep accurate payroll records showing the name, address, social security number, work classification, straight time and overtime hours worked each day and week, and the actual per diem wages paid to each journeyman, apprentice, worker, or other employee employed in performance of the Work. Each payroll record must contain or be verified by a written declaration that it is made under penalty of perjury, stating that the information contained in the payroll record is true and correct and that the employer has complied with the requirements of Sections 1771, 1811, and 1815 for any work performed by the employer's employees on the public works project. The payroll records required pursuant to California Labor Code Section 1776 must be certified and must be available for inspection by the District and its authorized representatives, the Division of Labor Standards Enforcement, and the Division of Apprenticeship Standards of the Department of Industrial Relations and must otherwise be available for inspection in accordance with California Labor Code Section 1776. In addition, in accordance with California Labor Code Section 1771.4, the Contractor and its subcontractor(s) shall furnish the records specified in California Labor Code Section 1776 directly to the Labor Commissioner at least monthly (or more frequently if specified in the Contract Documents); and in a format prescribed by the Labor Commissioner.
 6. In accordance with California Labor Code Section 1771.4, the Contractor shall post job site notices, as prescribed by regulation.
- f. By executing the Agreement, in accordance with California Labor Code Section 1771(a), the Contractor represents that it and all of its Subcontractors are currently registered and qualified to perform public work pursuant to Labor Code Section 1725.5. The Contractor covenants that any additional or substitute Subcontractors will be similarly registered and qualified.

- g. In accordance with California Labor Code Section 1777.5, the Contractor, on behalf of the Contractor and any subcontractors engaged in performance of the Work, will be responsible for ensuring compliance with California Labor Code Section 1777.5 governing employment and payment of apprentices on public works contracts.
- h. In case it becomes necessary for the Contractor or any subcontractor engaged in performance of the Work to employ on the Work any person in a trade or occupation (except executive, supervisory, administrative, clerical, or other non manual workers as such) for which no minimum wage rate has been determined by the Director of the Department of Industrial Relations, the Contractor must pay the minimum rate of wages specified therein for the classification which most nearly corresponds to Work to be performed by that person. The minimum rate thus furnished will be applicable as a minimum for such trade or occupation from the time of the initial employment of the person affected and during the continuance of such employment.

6-1.12 Laws and Ordinances. The Contractor and all subcontractors engaged in the performance of the Work must conform to the following specific rules and regulations as well as all other laws, ordinances, rules and regulations that apply to the Work. Nothing in the Technical Specifications or Project Plans is to be construed to permit Work not conforming to these codes:

- National Electrical Safety Code, U. S. Department of Commerce
- National Board of Fire Underwriters' Regulations
- California Building Standards Code as adopted by the District
- Manual of Accident Prevention in Construction, latest edition, published by A.G.C. of America
- Industrial Accident Commission's Safety Orders, State of California
- Regulations of the State Fire Marshall (Title 19, California Code of Regulation) and Applicable Local Fire Safety Codes
- Labor Code of the State of California - Division 2, Part 7, Public Works and Public Agencies.

6-1.13 Guaranty. The Contractor guarantees all of the Work for one year from the date the District accepts the Work. Upon receiving written notice of a need for repairs which are directly attributable to defective materials or workmanship the Contractor must make good any defects arising or discovered in any part of the Work by diligently commencing the necessary repairs within seven (7) days from the date of notice from the District. If the Contractor fails to make good any defects in the Work in accordance with this provision, in addition to any other available remedy under the contract or at law or equity, the District may make good or have made good such defects in the Work and deduct the cost from amounts that may be due or become due the Contractor, and/or call on the Contractor's maintenance bond for the cost of making good such defects and for the District's reasonable legal costs, if any, of recovering against the bond. The Contractor will remain

responsible for repairing any Work found to be defective regardless of when such defect is discovered by the District.

6-1.14 Safety.

- a. In accordance with generally accepted construction practices and applicable law, the Contractor will be solely and completely responsible for conditions of the Work site, including safety of all persons and property during performance of the Work. This requirement will apply continuously and not be limited to normal working hours. For purposes of California Labor Code Section 6400 and related provisions of law, the Contractor and the Contractor's privities and any other entities engaged in the performance of the Work will be "employers" responsible for furnishing employment and a place of employment that is safe and healthful for the employees, if any, of such entities engaged in the performance of the Work. Neither the District nor its officials, officers, employees, agents, volunteers or consultants will be "employers" pursuant to California Labor Code Section 6400 and related provisions of law with respect to the Contractor, the Contractor's privities or other entities engaged in the performance of the Work.
- b. Review and inspection by the District, the Engineer, the Designer or Engineer, and/or other representatives of the District of the Contractor's performance of the Work will not constitute review of the adequacy of the Contractor's safety measures in, on, or near the Work site. Such reviews and inspections do not relieve the Contractor of any of the Contractor's obligations under the Contract Documents and applicable law to ensure that the Work site is maintained and the Work is performed in a safe manner.
- c. The Contractor will be solely responsible for the implementation and maintenance of safety programs to ensure that the Work site is maintained and the Work is performed in a safe manner in accordance with the Contract Documents and applicable law.
- d. Within ten (10) working days following notice of award the Contractor must submit to the District a copy of the Contractor's Safety Plan.
- e. The Contractor must furnish and place proper guards and systems for the prevention of accidents, including, but not limited to, those systems required pursuant to Title 8, Section 1670 and following of the California Code of Regulations concerning safety belts and nets. The Contractor must provide and maintain any other necessary systems or devices required to secure safety of life or property at the Work site in accordance with accepted standards of the industry and applicable law. The Contractor must maintain during all night hours sufficient lights to prevent accident or damage to life or property.

6-1.15 Load Limitations.

- a. Unless expressly permitted in the Special Provisions, construction equipment or vehicles of any kind which, laden or unladen, exceed the maximum weight limitations set forth in Division 15 of the Vehicle Code, shall not be operated over completed or existing treated bases, surfacing, pavement or structures in any areas within the limits of the project.
- b. After application of the curing seal, no traffic or Contractor's equipment will be permitted on cement treated base or lean concrete base for a period of 72 hours. After 72 hours, traffic and equipment operated on the base shall be limited to that used in paving operations and placing additional layers of cement treated base. No traffic or Contractor's equipment will be permitted on treated permeable base except for that equipment required to place the permeable base and the subsequent layer of pavement. Trucks used to haul treated base, portland cement concrete, or asphalt concrete shall enter onto the base to dump at the nearest practical entry point ahead of spreading equipment. Empty haul trucks shall exit from the base at the nearest practical exit point. Entry and exit points shall not be more than 1,000 feet ahead of spreading equipment except in locations where specifications prohibit operation of trucks outside the area occupied by the base or where steep slopes or other conditions preclude safe operation of hauling equipment. In those locations, entry and exit points shall be established at the nearest point ahead of spreading equipment permitted by specifications and allowing safe operation of hauling equipment. Damage to curing seal or base shall be repaired promptly by the Contractor, at the Contractor's expense, as directed by the Engineer.
- c. Within the limits of the project and subject to the control of the Engineer, and provided that the Contractor, at the Contractor's expense, shall provide such protective measures as are deemed necessary by the Engineer and shall repair any damage caused by the operations, the Contractor will be permitted to:
 1. Make transverse crossings of those portions of an existing public road or street that are within the highway right of way, with construction equipment that exceeds the size or weight limitations set forth in Division 15 of the Vehicle Code.
 2. Make transverse crossings of treated bases, surfacing or pavement which are under construction or which have been completed, with construction equipment which exceeds the size or weight limitations set forth in Division 15 of the Vehicle Code.
 3. Cross bridge structures that are not open to public traffic and that are designed for HS20-44 Live Loading (culverts and pipes excluded), with construction equipment which exceeds the size or weight limitations set forth in Division 15 of the Vehicle Code, but not exceeding the load

limitations hereinafter specified, provided that the Contractor furnishes to the Engineer the dimensions and maximum axle loadings of equipment proposed for use on bridge structures:

- A. The maximum loading on bridge structures due to pneumatic-tired truck and trailer combinations shall not exceed (1) 28,000 pounds for single axles, (2) 48,000 pounds for tandem axles, nor (3) 60,000 pounds total gross load for single vehicles or 110,000 pounds total gross load for truck and trailer or semi-trailer combinations.
- B. The loading on bridge structures due to 2 and 3 axle pneumatic-tired earthmovers shall not exceed that shown in the following table.

Allowable Construction Loading On Bridges For 2 and 3 Axle Earthmovers

Spacing of Bridge Girders (center to center in feet)	Maximum Axle Loading (in pounds)
4	28,000
5	29,000
6	30,0
7	32,000
8	34,000
9	37,000
10 and over	40,000

Minimum axle spacing:

For 3-axle earthmovers
 Axles 1 to 2 = 8 feet
 Axles 2 to 3 = 20 feet

For 2-axle earthmovers
 Axles 1 to 2 = 20 feet

- 4. Move equipment within the limits of the project over completed or existing base, surfacing, pavement and structures, whether or not open to the public.
- d. Within the limits of the project and subject to the condition that the Contractor shall repair, at the Contractor's expense, any damage caused thereby, the Contractor will be permitted to cross culverts and pipes with construction equipment that exceeds the size or weight limitations set forth in Division 15 of the Vehicle Code in accordance with the conditions set forth on the Project Plans.
- e. Should the Contractor desire to increase the load carrying capacity of a structure or structures which are to be constructed as a part of the Agreement, in order to facilitate the Contractor's own operations, the Contractor may request the Engineer to consider redesigning the structure or structures. Proposals by the Contractor to increase the load carrying capacity of structures above 130,000

pounds per single axle or pair of axles less than 8 feet apart, or above 330,000 pounds total gross vehicle weight, will not be approved. The request shall include a description of the structure or structures involved and a detailed description of the overloads to be carried, the date the revised plans would be required, and a statement that the Contractor agrees to pay all costs involved in the strengthening of the structure or structures, including the cost of revised plans, and further that the Contractor agrees that no extension of time will be allowed by reason of any delay to the work which may be due to the alteration of the structure or structures. If the Engineer determines that strengthening the structure or structures will be permitted, the Engineer will inform the Contractor of the estimated cost of the alterations, including engineering, and the date that revised plans could be furnished. If the cost and date are satisfactory to the Contractor, the Engineer will prepare a change order providing for the agreed upon alterations.

6-1.16 Public Convenience.

- a. The Contractor shall so conduct operations as to offer the least possible obstruction and inconvenience to the public and shall have under construction no greater length or amount of Work than can be prosecuted properly with due regard to the rights of the public.
- b. Unless otherwise provided in the Special Provisions, all public traffic shall be permitted to pass through the Work with as little inconvenience and delay as possible. Where possible, public traffic shall be routed on new or existing paved surfaces.
- c. Spillage resulting from hauling operations along or across any public traveled way shall be removed immediately by the Contractor at the Contractor's expense.
- d. Existing traffic signals and highway lighting shall be kept in operation for the benefit of the traveling public during progress of the Work, and other forces will continue routine maintenance of existing systems.
- e. Construction operations shall be conducted in such a manner as to cause as little inconvenience as possible to abutting property owners.
- f. Convenient access to driveways, houses, and buildings along the line of the Work shall be maintained and temporary approaches to crossings or intersecting highways shall be provided and kept in good condition. When the abutting property owner's access across the right of way line is to be eliminated, or to be replaced under the contract by other access facilities, the existing access shall not be closed until the replacement access facilities are usable.

- g. The Contractor may be required to cover certain signs which regulate or direct public traffic to roadways that are not open to traffic. The Engineer will determine which signs shall be covered.
- h. Roadway excavation and the construction of embankments shall be conducted in such a manner as to provide a reasonably smooth and even surface satisfactory for use by public traffic at all times; sufficient fill at culverts and bridges to permit traffic to cross shall be placed in advance of other grading operations; and if ordered by the Engineer roadway cuts shall be excavated in lifts and embankments constructed part width at a time, construction being alternated from one side to the other and traffic routed over the side opposite the one under construction. Culvert installation or culvert construction shall be conducted on but one-half the width of the traveled way at a time, and that portion of the traveled way being used by public traffic shall be kept open and unobstructed until the opposite side of the traveled way is ready for use by traffic.
- i. Upon completion of rough grading at the grading plane, or placing any subsequent layer thereon, the surface of the roadbed shall be brought to a smooth, even condition free of humps and depressions, satisfactory for the use of public traffic.
- j. After the surface of the roadbed has been brought to a smooth and even condition for the passage of public traffic as above provided, any work ordered by the Engineer for the accommodation of public traffic prior to commencing subgrade operations will be paid for as extra work as provided in Section 3. After subgrade preparation for a specified layer of material has been completed, the Contractor shall, at the Contractor's expense, repair any damage to the roadbed or completed subgrade, including damage caused by the Contractor's operations or use by public traffic.
- k. While subgrade and paving operations are underway, public traffic shall be permitted to use the shoulders and, if half-width paving methods are used, shall also be permitted to use the side of the roadbed opposite the one under construction. When sufficient width is available, a passageway wide enough to accommodate at least 2 lanes of traffic shall be kept open at locations where subgrade and paving operations are in active progress.
- l. When ordered by the Engineer, the Contractor shall furnish a pilot car and driver and flaggers for the purpose of expediting the passage of public traffic through the Work under one-way controls. At locations where traffic is being routed through construction under one-way controls and when ordered by the Engineer, the movement of the Contractor's equipment from one portion of the Work to another shall be governed in accordance with the one-way controls.

- m. Water or dust palliative shall be applied if ordered by the Engineer for the alleviation or prevention of dust nuisance.
- n. In order to expedite the passage of public traffic through or around the work and where ordered by the Engineer, the Contractor shall install signs, lights, flares, temporary railing (Type K), barricades and other facilities for the sole convenience and direction of public traffic. Also where directed by the Engineer, the Contractor shall furnish competent flaggers whose sole duties shall consist of directing the movement of public traffic through or around the Work. The cost of furnishing and installing the signs, lights, flares, temporary railing (Type K), barricades, and other facilities, not to be paid for as separate contract items, will be paid for as provided in Section 3.
- o. The Contractor will be required to pay the cost of replacing or repairing all facilities installed for the convenience or direction or warning of public traffic that are lost while in the Contractor's custody, or are damaged by reason of the Contractor's operations to such an extent as to require replacement or repair, and deductions from any moneys due or to become due the Contractor will be made to cover the cost.
- p. Whenever a section of surfacing, pavement or the deck of a structure has been completed, the Contractor shall open it to use by public traffic if the Engineer so orders or may open it to use by public traffic if the Engineer so consents. In either case the Contractor will not be allowed any compensation due to any delay, hindrance or inconvenience to the Contractor's operations caused by public traffic, but will thereupon be relieved of responsibility for damage to completed permanent facilities caused by public traffic, within the limits of that use. The Contractor will not be relieved of any other responsibility under the contract nor will the Contractor be relieved of cleanup and finishing operations.
- q. Except as otherwise provided in this Section 6.1-16 or in the Special Provisions, full compensation for conforming to the provisions in this Section 6.1-16 shall be considered as included in the prices paid for the various contract items of work and no additional compensation will be allowed therefore.

6-1.17 Public Safety.

- a. It is the Contractor's responsibility to provide for the safety of traffic and the public during construction.
- b. Whenever the Contractor's operations create a condition hazardous to traffic or to the public, the Contractor shall, at the Contractor's expense and without cost to the District, furnish, erect and maintain those fences, temporary railing (Type K), barricades, lights, signs and other devices and take such other protective

measures that are necessary to prevent accidents or damage or injury to the public.

- c. Fences, temporary railing (Type K), barricades, lights, signs, and other devices furnished, erected and maintained by the Contractor, at the Contractor's expense, are in addition to any construction area traffic control devices for which payment is provided for elsewhere in the Agreement.
- d. The Contractor shall also furnish such flaggers as are necessary to give adequate warning to traffic or to the public of any dangerous conditions to be encountered.
- e. Signs, lights, flags, and other warning and safety devices and their use shall conform to the requirements set forth in Chapter 6 of the MUTCD. Signs or other protective devices furnished and erected by the Contractor, at the Contractor's expense, as above provided, shall not obscure the visibility of, nor conflict in intent, meaning and function of either existing signs, lights and traffic control devices or any construction area signs and traffic control devices for which furnishing of, or payment for, is provided elsewhere in the Agreement. Signs furnished and erected by the Contractor, at the Contractor's expense, shall be approved by the Engineer as to size, wording and location.
- f. The installation of general roadway illumination shall not relieve the Contractor of the responsibility for furnishing and maintaining any of the protective facilities herein before specified.
- g. Construction equipment shall enter and leave the highway via existing ramps and crossovers and shall move in the direction of public traffic. All movements of workmen and construction equipment on or across lanes open to public traffic shall be performed in a manner that will not endanger public traffic.
- h. The Contractor's trucks or other mobile equipment which leave a freeway lane, that is open to public traffic, to enter the construction area, shall slow down gradually in advance of the location of the turnoff to give following public traffic an opportunity to slow down.
- i. When leaving a Work area and entering a roadway carrying public traffic, the Contractor's equipment, whether empty or loaded, shall in all cases yield to public traffic.
- j. Lanes, ramps and shoulders shall be closed in accordance with the details shown on the plans, and as provided in the Special Provisions.

- k. The Contractor shall notify the Engineer not less than 18 days and not more than 90 days prior to the anticipated start of an operation that will change the vertical or horizontal clearance available to public traffic (including shoulders).
- l. Pedestrian openings through falsework shall be paved or provided with full width continuous wood walks and shall be kept clear. Pedestrians shall be protected from falling objects and curing water for concrete. Overhead protection for pedestrians shall extend not less than 4 feet beyond the edge of the bridge deck. All pedestrian openings through falsework shall be illuminated.
- m. When vertical clearance is temporarily reduced to 15 feet, or less, low clearance warning signs shall be placed in accordance with Chapter 2 of the MUTCD and as directed by the Engineer. Signs shall conform to the dimensions, color, and legend requirements of the MUTCD, and these specifications except that the signs shall have black letters and numbers on an orange retroreflective background. W12-2P signs shall be illuminated so that the signs are clearly visible.
- n. No material or equipment shall be stored where it will interfere with the free and safe passage of public traffic, and at the end of each day's Work and at other times when construction operations are suspended for any reason, the Contractor shall remove all equipment and other obstructions from that portion of the roadway open for use by public traffic.
- o. Temporary facilities which the Contractor uses to perform the Work shall not be installed or placed where they will interfere with the free and safe passage of public traffic.
- p. Temporary facilities which could be a hazard to public safety if improperly designed shall comply with design requirements specified in the Agreement for those facilities or, if none are specified, with standard design criteria or codes appropriate for the facility involved. Working drawings and design calculations for the temporary facilities shall be prepared and signed by an engineer who is registered as a Civil Engineer in the State of California and shall be submitted to the Engineer for approval. The submittals shall designate thereon the standard design criteria or codes used. Installation of the temporary facilities shall not start until the Engineer has reviewed and approved the drawings.
- q. Should the Contractor appear to be neglectful or negligent in furnishing warning devices and taking protective measures as above provided, the Engineer may direct attention to the existence of a hazard and the necessary warning devices shall be furnished and installed and protective measures taken by the Contractor at the Contractor's expense. Should the Engineer point out the inadequacy of warning devices and protective measures, that action on the part of the Engineer

shall not relieve the Contractor from responsibility for public safety or abrogate the obligation to furnish and pay for these devices and measures.

- r. Provision for the payment for signs, lights, flares, temporary railing (Type K), barricades, and other facilities as provided in Section 6-1.16, "Public Convenience," or by contract item, shall in nowise relieve the Contractor from the responsibility as provided in this Section 6-1.17.
- s. Except as otherwise provided in this Section 6-1.17 or in the special provisions, full compensation for conforming to all of the provisions in this Section 6-1.17 shall be considered as included in the prices paid for the various contract items of Work and no additional compensation will be allowed therefore.

6-1.18 Preservation of Property.

- a. Roadside trees, shrubs and other plants that are not to be removed, and pole lines, fences, signs, markers and monuments, buildings and structures, conduits, pipelines under or above ground, sewer and water lines, all highway facilities and any other improvements or facilities within or adjacent to the highway shall be protected from injury or damage, and if ordered by the Engineer, the Contractor shall provide and install suitable safeguards, approved by the Engineer, to protect the objects from injury or damage. If the objects are injured or damaged by reason of the Contractor's operations, the objects shall be replaced or restored at the Contractor's expense. The facilities shall be replaced or restored to a condition as good as when the Contractor entered upon the Work, or as good as required by the Agreement, if any of the objects are a part of the Work. The Engineer may make or cause to be made those temporary repairs that are necessary to restore to service any damaged highway facility. The cost of the repairs shall be borne by the Contractor and may be deducted from any moneys due or to become due to the Contractor under the contract.
- b. The fact that any underground facility is not shown upon the Project Plans shall not relieve the Contractor of the responsibility under Section 4-1.05, "Utility and Non-Highway Facilities." It shall be the Contractor's responsibility, pursuant thereto, to ascertain the location of those underground improvements or facilities which may be subject to damage by reason of the Contractor's operations.
- c. Full compensation for furnishing all labor, materials, tools, equipment, and incidentals, and for doing all the Work involved in protecting or repairing property as specified in this Section 6-1.18, shall be considered as included in the prices paid for the various contract items of Work and no additional compensation will be allowed therefore.

6-1.19 Sound Control Requirements. The Contractor shall comply with all local sound control and noise level rules, regulations and ordinances which apply to any Work

performed pursuant to the Agreement. Each internal combustion engine, used for any purpose on the job or related to the job, shall be equipped with a muffler of a type recommended by the manufacturer. No internal combustion engine shall be operated on the project without the muffler.

6-1.20 Disposal Of Material Outside The Right Of Way.

- a. If the Contractor elects to dispose of materials at locations other than those where arrangements have been made by the District, or, if material is to be disposed of and the District has not made arrangements for disposal of the material, the Contractor shall make arrangements for disposing of the materials outside the highway right of way and shall pay all costs involved. Arrangements shall include, but not be limited to, entering into agreements with property owners and obtaining necessary permits, licenses and environmental clearances. Before disposing of any material outside the highway right of way, the Contractor shall furnish to the Engineer satisfactory evidence that the Contractor has entered into agreements with the property owners of the site involved and has obtained the permits, licenses and clearances.
- b. When any material is to be disposed of outside the highway right of way, and the District has not made arrangements for disposal of the material, the Contractor shall first obtain written authorization from the property owner on whose property the disposal is to be made and the Contractor shall file with the Engineer the authorization or a certified copy thereof together with a written release from the property owner absolving the District from any and all responsibility in connection with the disposal of material on the property. Before any material is disposed of on the property, the Contractor shall obtain written permission from the Engineer to dispose of the material at the location designated in the authorization. When material is disposed of as above provided and the disposal location is visible from a highway, the Contractor shall dispose of the material in a neat and uniform manner to the satisfaction of the Engineer.
- c. Where the District has made arrangements with owners of land in the vicinity of a project for the disposal of materials on an owner's property, the arrangements are made solely for the purpose of providing all bidders an equal opportunity to dispose of the materials on the property. Bidders or Contractors may, upon written request, inspect the documents evidencing the arrangements between property owners and the District. The Contractor may, if the Contractor so elects, exercise any rights that have been obtained, which may be exercised by a Contractor under the arrangements, subject to and upon the conditions hereinafter set forth.
- d. Such arrangements are not a part of the Agreement and it is expressly understood and agreed that the District assumes no responsibility to the Contractor whatsoever in respect to the arrangements made with the property owner to dispose of materials thereon and that the Contractor shall assume all risks in connection with the use of the property, the terms upon which the use shall be made, and there is no warranty

or guaranty, either express or implied, as to the quantity or types of materials that can be disposed of on the property.

- e. In those instances in which the District has compiled "Materials Information" as referred to in Section 3, "Examination of Plans, Specifications, Contract, and Site of Work," of Instructions to Bidders, the compilation will include the documents setting forth the arrangement made with some of the property owners for the disposal of material on those owners' properties. The inclusion of the documents therein shall not in any respect operate as a waiver of any of the provisions in this Section 6-1.20 concerning the documents.
- f. The Contractor is cautioned to make such independent investigation and examination as the Contractor deems necessary to be satisfied as to the quantity and types of materials which may be disposed of on the property and the rights, duties and obligations acquired or undertaken under the arrangement with the property owner.
- g. Notwithstanding that the Contractor may elect to dispose of materials on any such property owner's property, no material may be disposed of on that property unless the Contractor has first either:
 - 1. Executed a document that will guarantee to hold the owner harmless from all claims for injury to persons or damage to property resulting from the Contractor's operations on the property owner's premises and also agree to conform to all other provisions set forth in the arrangement made between the District and the property owner. The document will be prepared by the Engineer for execution by the Contractor, or
 - 2. Entered into an agreement with the owner of the disposal site on any terms mutually agreeable to the owner and the Contractor; provided that the Contractor shall furnish to the Engineer a release, in a form satisfactory to the Engineer, executed by the owner, relieving the District of any and all obligations under the District's arrangement with the owner.
- h. If the Contractor elects to dispose of material under (1), the use of the site shall be subject to the terms, conditions and limitations of the arrangement made between the property owner and the District and the Contractor shall pay those charges that are provided for in the arrangement made by the District with the property owner, and deductions will be made from any moneys due or that may become due the Contractor under the contract sufficient to cover the charges for the material disposed of.
- i. If the Contractor elects to dispose of material under (2), the Contractor shall pay those charges that are provided for in the agreement between the owner and the

Contractor and deductions will not be made from any moneys due or that may become due the Contractor under the contract to cover the charges.

- j. The Engineer may require the Contractor to submit written evidence that the owner of the disposal site is satisfied that the Contractor has satisfactorily complied with the provisions of either - (1), the arrangement between the Department and the owner, or (2), the agreement between the owner and the Contractor, as the case may be.
- k. Full compensation for all costs involved in disposing of materials as specified in this Section 6-1.20, including all costs of hauling, shall be considered as included in the price paid for the contract item of work involving the materials and no additional compensation will be allowed therefore.

6.1-21 Assignment of Unfair Business Practice Claims. In accordance with California Public Contract Code Section 7103.5, the Contractor and any subcontractors offer and agree to assign to the District all rights, title, and interest in and to all causes of action the Contractor or any subcontractors may have under Section 4 of the Clayton Act (15 U.S.C. § 15) or under the Cartwright Act (Chapter 2 (commencing with § 16700) of Part 2 of Division 7 of the Business and Professions Code), arising from purchases of goods, services or materials pursuant to this contract. This assignment shall be made and become effective at the time the District tenders final payment to the Contractor, without further acknowledgement by the parties.

6-1.22 Notice of Potential Claim

- a. If for any reason the Contractor deems that additional compensation is due for Work or materials not clearly provided for in the Agreement, Project Plans or Technical Specifications or previously authorized extra work, a Notice of Potential Claim shall be made. The Contractor shall give the Engineer a written Notice of Potential Claim concerning such additional compensation before Work begins on the items on which the claim is based. The notice shall set forth the reasons for which the Contractor believes additional compensation will or may be due and the nature of the costs involved. Any Notice of Potential Claim submitted to the District by the Contractor shall have attached the following certification executed by an officer of the Contractor:

I, _____, being the _____ of _____ (Contractor), declare under penalty of perjury under the laws of the State of California, and do personally certify and attest that: I have thoroughly reviewed the attached claim and know its contents, and said claim is made in good faith; that it is supported by truthful and accurate data; that the amount requested accurately reflects the contract adjustment for which the Contractor believes the District is liable; and further, that I am familiar with California Penal Code section 72 and California Government Code section 12650, et seq., pertaining to false claims, and

further know and understand that submission or certification of a false claim may lead to fines, imprisonment, or other severe legal consequences.

- b. The Contractor shall afford the Engineer every opportunity and facility for keeping records of actual cost of the work. The Contractor shall keep records of the disputed work in accordance with Section 3-1.17, Change Order Pricing.
- c. If such notification is not given or the Engineer is not afforded proper opportunity by the Contractor for keeping strict account of actual cost as required, then the Contractor hereby agrees to waive any claim for such additional compensation. Such notice by the Contractor and the fact that the Engineer has kept account of the cost of the Work shall not in any way be construed as proving or substantiating the validity of the claim. When the Work on the which the claim for additional compensation is based has been completed, the Contractor shall within 10 calendar days of completion submit the Contractor's written claim to the Engineer, who will present it to the District for consideration in accordance with the Agreement, including, but not limited to Section 11-1.03 of the General Provisions and applicable law.
- d. Any claim for overhead type expense or costs, in addition to being certified as stated above, shall be supported by an audit report of an independent Certified Public Accountant. Any claim for overhead shall also be subject to audit by the District at its discretion.
- e. Any costs or expenses incurred by the District in reviewing or auditing any claims that are not supported by the Contractor's cost accounting or other records shall be deemed to be damages incurred by the District within the meaning of the California False Claims Act.

SECTION 7 MEASUREMENT AND PAYMENT

7-1.01 F.O.B. All shipments must be F.O.B. destination to the Work site and/or other sites indicated in the Contract Documents. The Contract Price is all-inclusive (including sales tax). There shall be no additional compensation paid for containers, packing, unpacking, drayage or insurance. The Contract Prices includes full compensation for all taxes which the Contractor is required to pay, whether imposed by Federal, State or local government, including, without being limited to, Federal excise tax. No tax exemption certificate nor any document designed to exempt the Contractor from payment of any tax will be furnished to the Contractor by the District, as to any tax on labor, services, materials, transportation, or any other items furnished pursuant to this Agreement.

7-1.02 Payment.

- a. On or about the first day of each calendar month the Contractor will submit to the Engineer a verified application for payment and schedule of values supported by a statement showing all materials actually installed during the preceding month and the cost of labor actually expended in the performance of the Work. Unless otherwise provided in the Contract Documents, no allowances or payments will be made for material or equipment not placed at the Work site. Each invoice shall contain the following certification executed by a duly authorized officer of the Contractor:

I, _____, being the _____ of _____ (Contractor), declare under penalty of perjury under the laws of the State of California, and do personally certify and attest that: I have thoroughly reviewed the attached application for payment and know its contents, and said application is made in good faith; that it is supported by truthful and accurate data; that the amount requested accurately reflects the costs incurred during the period covered by this application; and further, that I am familiar with California Penal Code section 72 and California Government Code section 12650, et seq., pertaining to false claims, and further know and understand that submission or certification of a false claim may lead to fines, imprisonment, or other severe legal consequences.

- b. To be eligible for payment, the Contractor's applications for payment must include certified payroll reports prepared in accordance with California Labor Code Section 1776 and the Agreement for each employee of the Contractor and any subcontractors engaged in the performance of the Work during the preceding months. Applications for payment will not be processed without certified payroll reports.

- c. In accordance with California Public Contract Code Section 20104.50, the District will review applications for payment as soon as practicable after receipt. Any application or part of an application that is determined to be improper will be returned to the Contractor as soon as practicable, but no later than seven days after receipt by the District, along with a written description of the reasons why the application is improper. The Contractor's failure to submit a schedule in the time specified in Section 3-1.10 or its submission of a schedule to which the District has taken any uncorrected exception, shall serve as a basis for returning an application for payment in its entirety.
- d. Unless the Contractor has elected to post securities in lieu of retention in accordance with California Public Contract Code Section 22300 and the Agreement, and the Contractor and the District have executed an escrow agreement in accordance with Public Contract Code Section 22300 and the Agreement, the District will make progress payments to the Contractor in accordance with applicable law in the amount of ninety five (95) percent of the value of the labor actually performed and the material incorporated in the Work as specified in Contractor's verified application for payment upon approval by the District's authorized representative(s). Payment of progress payments will not be construed as acceptance of the Work performed. If the Contractor has elected to post securities in lieu of retention in accordance with Public Contract Code Section 22300 and the Agreement and the Contractor and the District have executed an escrow agreement in accordance with Public Contract Code Section 22300 and the Agreement, the District will make payments to the Contractor or the Contractor's escrow agent in accordance with such escrow agreement.
- e. The District will pay the Contractor's final invoice in accordance with applicable law and this Section 7 following acceptance of the Work provided that:
 - 1. The Contractor has furnished evidence satisfactory to the District that all claims for labor and material have been paid, or the time for filing valid stop notices has passed and no stop notices have been filed, or all stop notices filed have been released by valid release or release bond acceptable to the District.
 - 2. No claim has been presented to the District by any person based upon any acts or omissions of the Contractor or any subcontractor engaged in the performance of the Work.
 - 3. No other claim or dispute exists under the Agreement or applicable law concerning payment of the Contractor's final invoice and/or release of the Agreement retention.
 - 4. The Contractor has filed with the District the Maintenance Bond provided in the Contract Documents with duly notarized signatures of an authorized representative of the Contractor and an attorney-in-fact of an admitted surety

insurer acceptable to the District and such Maintenance Bond binds the Contractor as Principal and the Surety in accordance with its terms in the amount of 10% of the final Contract Price.

- f. In accordance with California Public Contract Code Section 20104.50, if the District fails to make a progress payment within thirty (30) days of receipt of an undisputed, properly submitted application for payment, the District will pay the Contractor interest equivalent to the legal rate set forth in subdivision (a) of California Code of Civil Procedure Section 685.010. The number of days available to the District to make a payment without incurring an interest obligation pursuant to this provision and California Public Contract Code Section 20104.50 will be reduced by the number of days, if any, by which the District has delayed return of an application for payment beyond the seven day return requirement set forth in Section 7-1.02.

7-1.03 Non-Allowable Direct Charges. The following costs are not allowable direct charges under the Agreement. The following costs may only be paid under the Agreement, if at all, as part of any allowance for Contractor overhead and/or profit established under the Agreement.

- a. Labor costs in excess of applicable prevailing wages pursuant to the Agreement and applicable law, liability and workers compensation insurance, social security, retirement and unemployment insurance and other employee compensation and benefits pursuant to bona fide compensation plans in effect at the time specified for the opening of Project bids for Contractor and subcontractor employees engaged in the performance of the Work. However, in no event will allowable direct labor charges under the agreement include employee bonuses, employee vehicles or vehicle allowances, employee telephones or telephone allowances, or employee housing or housing allowances, whether or not such benefits are part of a bona fide compensation plan in effect at the time specified for the opening of Project bids.
- b. Superintendent labor and clerical labor.
- c. Bond premiums.
- d. Insurance in excess of that required under Section 6-1.08.
- e. Utility costs.
- f. Work Site office expenses.
- g. Home office expenses.

7-1.04 Retention. The District or its agent may, in accordance with the Contract Documents and applicable law, withhold any payment of monies due or that may become due the Contractor because of:

- a. Defective work not remedied or uncompleted work.
- b. Claims filed or reasonable evidence indicating probable filing of claims.

- c. Failure to properly pay subcontractors or to pay for material or labor.
- d. Reasonable doubt that the Work can be completed for the balance then unpaid.
- e. Damage to another contractor.
- f. Damage to the District.
- g. Damage to a third party.
- h. Delay in the progress of the Work, which, in the District's judgment, is due to the failure of the Contractor to properly expedite the Work.
- i. Liquidated damages or other charges that apply to the Contractor under the Agreement.
- j. Any other lawful basis for withholding payment under the contract.

7-1.05 Securities in Lieu of Retention.

- a. In accordance with Public Contract Code Section 22300, except where federal regulations or polices do not permit substitution of securities, the Contractor may substitute securities for any moneys withheld by the District to ensure performance of the Work. At the Contractor's request and expense, securities equivalent to the amount withheld will be deposited with the District, or with a state or federally chartered bank in California as the escrow agent, who will then pay those moneys to the Contractor under the terms of an Escrow for Security Deposit agreement. The Escrow for Security Deposit agreement is provided in the Contract Documents. Upon satisfactory completion of the Work, the securities will be returned to the Contractor.
- b. Alternatively, at the Contractor's request and expense, the District will pay retentions earned directly to the escrow agent. At the Contractor's expense, the Contractor may direct investment of the payments into securities. Upon satisfactory completion of the Work, the Contractor will receive from the escrow agent all securities, interest, and payments received by the escrow agent from the District pursuant to this provision and the terms of the Escrow for Security Deposit agreement. The Contractor will, within 20 days of receipt of payment, pay to each subcontractor the respective amount of interest earned, less costs of retention withheld from each Subcontractor, on monies withheld to ensure the Contractor's performance of the Work.
- c. Securities eligible for investment in accordance with this provision include those listed in Government Code Section 16430, bank or savings and loan certificates of deposit, interest bearing demand deposit accounts, standby letters of credit, or any other security mutually agreed to by the Contractor and the District.
- d. The Contractor will be the beneficial owner of any securities substituted for moneys withheld and will receive any interest thereon.

SECTION 8

PROJECT ACCEPTANCE AND CLOSEOUT

8-1.01 Occupancy. The District reserves the right to occupy or use any part or parts or the entire of the Work before the Work is fully performed. Subject to applicable law, exercising this right will in no way constitute acceptance of any part of the Work so occupied or used or acceptance of the entire Work, nor will such occupancy or use in any way affect the times when payments will become due the Contractor, nor will such occupancy or use in any way prejudice the District's rights under the Agreement, any Agreement bonds, or at law or equity. Occupancy or use shall not waive the District's rights to assess liquidated damages in accordance with Section 5 after the date of such occupancy or use.

8-1.02 Work Completion and Final Inspection. When the Contractor considers the Work is completed, the Contractor will submit written certification to the Engineer specifying that: the Contract Documents have been reviewed; the Work has been inspected for compliance with the Contract Documents; the Work has been completed in accordance with the Contract Documents; and that equipment and systems have been tested in the presence of the District's representative and are operational. The District and/or the District's authorized representatives will make an inspection to verify that the Work is complete and will notify the Contractor in writing of any incomplete or deficient Work. The Contractor will take immediate steps to remedy the stated deficiencies and give notice of correction to the Engineer. Upon receiving a notice of correction, the District or the District's authorized representatives will re-inspect the Work. The Contractor must correct all punch list items within 15 working days after the issuance of the punch list. Before acceptance of the Work the Contractor must submit: one set of the Project Record Drawings (As-Built), and any equipment operating and maintenance instructions and data, warranties.

8-1.03 Work Acceptance.

- a. All finished Work will be subject to inspection and acceptance or rejection by the District, the Engineer, and the Designer or other government agencies having jurisdiction over the Work. Final acceptance of the Work will be at the discretion of the District.
- b. The District will accept the Work in writing only when the Work has been completed to the District's reasonable satisfaction. Progress payments will in no way be construed as acceptance of any part of the Work

- c. In evaluating the Work, no allowance will be made for deviations from the Technical Specifications, Project Plans or other Contract Documents unless already approved in writing in accordance with the requirements of Section 3, above.

- d. The fact that the Work and materials have been inspected from time to time and that progress payments have been made does not relieve the Contractor of the responsibility of replacing and making good any defective or omitted work or materials in accordance with the requirements of the Contract Documents.

SECTION 9 REMEDIES AND DISPUTES

9-1.01 Failure to Correct Work. Within ten (10) working days of receiving written notice from the District describing Work that is defective or that is otherwise not in accordance with the requirements of the Agreement and/or applicable law and directing that such Work be corrected, the Contractor and/or the Contractor's sureties must give the District written notice of the intent of the Contractor and/or the Contractor's sureties to correct such Work and commence correction of such Work in accordance with the District's notice and the Agreement. If the Contractor and/or the Contractor's sureties do not give the District written notice of intent to correct such Work and commence correction of such Work within ten (10) working days of receipt of the District's notice, then the District may correct such work and/or have such work corrected for the account and at the expense of the Contractor and/or its sureties, and the Contractor and/or its sureties will be liable to the District for any resulting excess cost. The District may, in addition to all other remedies that the District may have under the Agreement and at law or equity, deduct any such excess cost of completing the Work from amounts that are due or that may become due the Contractor.

9-1.02 Termination.

- a. In accordance with California Public Contract Code Section 7105, in addition to all other available remedies that the District may have under the Agreement, and at law or equity, the District may terminate the Agreement:
 1. If the Contractor or any of its subcontractors engaged in the performance of the Work fails to timely perform the Work and/or any of the Contractor's material obligations under the Contract Documents, including but not limited to submission of an acceptable schedule, that have accrued except for those due to reasons beyond the control of the Contractor pursuant to the Contract Documents.
 2. If the Contractor is adjudged bankrupt, or if it should make a general assignment for the benefit of creditors, or if a receiver should be appointed on account of its creditors.
 3. If the Contractor or any of the subcontractors engaged in the performance of the Work persistently or repeatedly refuses or fails to supply enough properly skilled workmen or proper materials for the timely completion of the Work.
 4. If the Contractor fails to make prompt payment to subcontractors engaged in the performance of the Work or for material or labor used in the

performance of the Work in accordance with the Contract Documents and applicable law.

5. If the Contractor or any subcontractors engaged in the performance of the Work persistently disregards laws or ordinances applicable to the performance of the Work, or the instructions of the District, the Engineer, the Designer, or other authorized representatives of the District.
 6. For any reason or for no reason, at the District's sole discretion.
- b. If the District intends to terminate the Contractor's control of the Work for any of the reasons specified in Section 9-1.02(a) 1 through 5, above, the District will immediately serve written notice to the Contractor and its sureties in accordance with the Contract Documents. Notice of the District's intent to terminate the Agreement will be given by registered or certified mail and specify the grounds for termination, the required cure and the time by which the cure must be effected. Upon receipt of notice of the District's intent to terminate the Agreement for any of the reasons specified in Section 9-1.02(a) 1 through 5, the Contractor will have ten (10) days from receipt of the notice or a longer time specified in the notice to cure its default. If the Contractor does not effect the required cure by the time specified in the notice, the District will issue a written notice of termination to the Contractor and its sureties by registered or certified mail. The notice of termination will specify: that upon receipt of the notice the Contractor's right to perform or complete the Work, including on behalf of the Contractor's sureties, is terminated; that the Contractor's sureties will have the right to take over and complete the Work and perform all of the Contractor's remaining obligations that have accrued under the Agreement; and that if the Contractor's sureties do not both give the District written notice of their intention to take over and perform the Agreement and commence completion of the Work and performance of all of the Contractor's remaining obligations that have accrued under the Agreement within ten (10) days after receipt of notice of termination that the District may declare the Contractor's sureties in default and take over the completion of the Work or have the Work completed for the account and at the expense of the Contractor and its sureties, and the Contractor and its sureties will be liable to the District for any resulting excess cost. The District may, in addition to all other available remedies that the District may have under the Contract Documents and at law or equity, deduct any such excess cost of completing the Work from amounts that are due or that may become due the Contractor.
- c. Upon termination of the Contractor's control of the Work for any of the reasons specified in Section 9-1.02(a) 1 through 5, the Contractor will, if so directed by the District, immediately remove from the Work site any and all materials and personal property belonging to the Contractor which have not been incorporated in the Work and the Contractor and its sureties will be liable upon their bond

for all damages caused the District by reason of the Contractor's failure to complete the Work.

- d. Upon termination of the Contractor's control of the Work for any of the reasons specified in Section 9-1.02(a) 1 through 5, above, the District reserves the right to refuse tender of the Contractor by any surety to complete the Work.
- e. If the District completes or has completed any portion of, or the whole of the Work, following termination of the Contractor's control of the Work for any of the reasons specified in Section 9-1.02(a) 1 through 5, above, the District will neither be liable for nor required to account to the Contractor or the Contractor's sureties in any way for the time within which, or the manner in which such Work is performed, or for any changes made in such Work or for the money expended in satisfying claims and/or suits and/or other obligations in connection with completing the Work. If, following termination of the Contractor's control of the Work for any of the reasons specified in Section 9-1.02(a) 1 through 5, above, the unpaid balance of the Contract Price exceeds the expense of completing the Work, including compensation for additional legal, managerial and administrative services and all other amounts due for the completion of the Work and/or satisfaction of claims of the District and/or others arising out of the Agreement and any other charges that apply to the Contractor under the Agreement, the difference will be paid to the Contractor. If such expenses of completing the Work exceed the unpaid balance of the Contract Price, the Contractor or its sureties will pay the difference to the District.
- f. If the Agreement or Contractor's control of the Work is terminated for any reason, no allowances or compensation will be granted for the loss of any anticipated profit by the Contractor.
- g. In accordance with California Government Code Section 4410, in the event a national emergency occurs, and public work being performed by contract is stopped, directly or indirectly, because of the freezing or diversion of materials, equipment or labor, as the result of an order or a proclamation of the President of the United States, or of an order of any federal authority, and the circumstances or conditions are such that it is impracticable within a reasonable time to proceed with a substantial portion of the Work, then the District and the Contractor may, by written agreement, terminate the Agreement. In accordance with California Government Code Section 4411, such an agreement will include the terms and conditions of the termination of the Contract and provision for the payment of compensation or money, if any, which either party will pay to the other or any other person, under the facts and circumstances in the case. Compensation to the Contractor will be determined on the basis of the reasonable value of the Work done, including preparatory Work. As an exception to the foregoing, in the case of any fully completed separate item or portion of the Work for which there is a separate contract price, the Contract

Price shall control. The parties may in any other case adopt the Contract Price as the reasonable value of the Work or any portion of the Work done.

9-1.03 Disputes.

9-1.03.01 Definitions

For purposes of this section, the following Definitions shall apply:

- A. “Disputed Work” - Work that Contractor contends is outside the scope of the Contract Documents or in violation of the terms of the Contract Documents, resulting from any decision, determination, order, direction, instruction, notice, action, or omission of the District being otherwise incorrect or improper. Disputed Work includes any claims or potential claims regarding loss of productivity, delays, impacts, arising or occurring during the Work, that Contractor may assert resulted from acts or omissions of the District that were outside the requirements of the Contract Documents.
- B. “Good Faith Negotiations” means the successive, tiered negotiations of Disputed Work, each with increasing levels of documentation and substantiation, starting at the Project level and escalating to the Authorized Representative level, then the Executive level, prior to Contractor filing a Final Claim.
- C. “Claim” or “statutory claim” is defined in Public Contract Code section 9104, and means “a separate demand by the contractor sent by registered mail or certified mail with return receipt requested, for one or more of the following:
 - a. A time extension, including, without limitation, for relief from damages or penalties for delay assessed by a public entity under a public works contract.
 - b. Payment by the District of money or damages arising from work done by, or on behalf of, the Contractor pursuant to the contract for a public work and payment for which is not otherwise expressly provided or to which the claimant is not otherwise entitled.
 - c. Payment of an amount that is disputed by the public entity.
- D. Final Claim means the certified Final Claim prepared and submitted by Contractor if Good Faith Negotiations fail to result in settlement of the claim.

9-1.03.02 Requirements of Good Faith Negotiations

A. Introduction

- a. At any time during the Good Faith Negotiations defined in this Section, Contractor may serve a statutory claim pursuant to Public Contract Code section 9204. Upon receipt of a claim pursuant to that section, the District will conduct a reasonable review of the claim and, within a period not to exceed 45 days, shall provide Contractor a written statement identifying what portion of the claim is disputed and what portion is undisputed. Upon receipt of a claim, the District and Contractor may, by mutual agreement,

extend the time period provided in this subdivision. Contractor shall furnish reasonable documentation to support the claim.

- b. Notwithstanding the service of a statutory claim, Contractor must comply with the Good Faith Negotiations procedures defined in this Section. Failure to so comply shall operate as a waiver of Contractor's claims.

B. Notification of Disputed Work Required.

- a. Contractor shall promptly, and before commencing Disputed Work, notify The District's Authorized Representative in writing before proceeding with such Work. Contractor's written notification shall state the objection and the basis of the objection ("Disputed Work").
- b. If Contractor proceeds with the Disputed Work without complying with the written notice requirement, Contractor will be deemed to have assented that the Work is within the Contract's requirements, and shall waive its rights to further right to a protest or Claim.
- c. Contractor shall provide written notice of Disputed Work concurrently with Contractor's incurring any costs it may claim are the responsibility of the District.

C. Contemporaneous Records

- a. Beginning with the first day on which any Disputed Work is performed, and each following Day, Contractor shall maintain detailed hourly records of labor, construction equipment, and services, and itemized records of materials and equipment used each Day in the performance of the Disputed Work. Such records must be of a form acceptable to the District, shall be signed by Contractor, copies provided to the District daily, and are subject to verification by the District.

D. Initial Substantiation (within ten (10) Days after Contractor's first knowledge of the Disputed Work.)

- a. Within ten (10) Days after Contractor's first knowledge of the Disputed Work, Contractor shall provide the District with a written statement of dispute ("Dispute") that includes a preliminary cost proposal for the Disputed Work stating clearly and in detail its objection and reasons for contending the Disputed Work is outside or in breach of the requirements of Contract Documents. The preliminary cost proposal must provide a good faith preliminary estimate of the labor (workers, crews), equipment and/or materials involved, and a corresponding good faith preliminary estimate of cost. It is the responsibility of Contractor to substantiate that the Disputed Work is in fact a change from the base scope of Work.
- b. The written Dispute must identify the subcontractors, vendors, suppliers affected, if any, sufficient for the District to visit the Site to inspect the work and/or conduct a telephonic interview of the persons involved, and/or to photograph the work in question. Contractor shall provide by email digital photographs of the Disputed Work and provide District with contact

information for all involved subcontractors and/or suppliers of any tier to facilitate prompt “in person” review at the next job site meeting.

E. First Negotiation: At Project Level. (No later than twenty-one (21) Days after Contractor’s first knowledge of the Dispute).

- a. The written notice and preliminary cost proposal for Disputed Work must be placed, by Contractor, as either a specific discussion item on the Agenda for the next weekly meeting, or to occur immediately before or following the weekly meeting. Both Owner and Contractor shall then make a good-faith effort to review the Disputed Work. It is expected that discussions will occur no later than twenty-one (21) Days after Contractor’s first knowledge of the Dispute.

F. Updated Dispute Substantiation (no later than thirty (30) days of Contractor’s first knowledge of Disputed Work).

- a. In the event negotiations at the next job site meeting do not result in resolution of the Dispute, and in any event no later than thirty (30) days of Contractor’s first knowledge of Disputed Work, Contractor must update its Dispute (“Updated Dispute”) to meet the following requirements.
- b. Contractor shall submit the Updated Dispute documentation in the following format:
 1. Introduction and Issue Identification
 2. Background
 3. Chronology
 4. Contractor's Position (Reason for County's potential liability)
 5. Supporting documentation of merit
 6. Supporting documentation of damages
 7. Schedules (if appropriate)
 8. Productivity exhibits (if appropriate)
- c. Contractor shall explain, cite by reference to Contract Documents and documents from the Project record and/or submit photocopies of documents supporting the merit of its position.
- d. Contractor shall explain, cite by reference to, and/or submit photocopies of documents supporting damages. Contractor must submit substantial supporting documentation with this Updated Dispute documentation; categories and amounts not identified and justified, will be deemed waived. Contractor may not assert, subsequently, new or different categories or amounts of damages.

G. Second Negotiation: At Project Representative Level. (No later than forty-five (45) Days after Contractor’s first knowledge of the Dispute).

- a. If District and Contractor do not resolve the Disputed Work at their first meeting, then Contractor shall submit its Updated Dispute and shall

calendar the matter for discussion with Contractor's Representative and Owner's Representative to occur within twenty (20) Days of the weekly meeting and no later than forty-five (45) Days after Contractor's first knowledge of the Dispute.

- b. The District's Representative will consider the information provided by Contractor and from District's resources, and will provide a decision in writing. If Contractor disputes the written decision, then Contractor's remedy is to file a Notice of Potential Claim meeting the requirements below.
- c. If for any reason Owner should fail to act or provide a decision on a Dispute or Updated Dispute, all within the required forty-five (45) Days, then the Dispute and Updated Dispute shall be deemed denied by Owner's Representative on the forty-sixth (46th) Day.

H. Notice of Potential Claim (no later than fifty-five (55) Days after Contractor's first knowledge of the Dispute).

- a. If, after receiving District's Representative's decision, Contractor disagrees with it or still considers the Disputed Work required of it to be outside the requirements of the Contract Documents, then Contractor shall so notify District in writing within ten (10) Days after receiving the decision by submitting a Notice of Potential Claim ("NOPC") stating that it will issue a formal claim.

I. Third Negotiation: Meeting of Executives.

- a. Upon receipt of Contractor's NOPC, Contractor and District shall negotiate the claim between and among the Contractor's Representative and Owner's Representative. Negotiations in response to the NOPC will not extend the time to file the Formal Claim.

J. FINAL CLAIM AND CERTIFICATION (Within seventy-five (75) Days of Contractor's first knowledge of a Dispute, or within thirty (30) Days of Owner's written decision on Contractor's Dispute and Updated Dispute.)

- a. Within seventy-five (75) Days of Contractor's first knowledge of a Dispute, or within thirty (30) Days of District's written decision on Contractor's Dispute and Updated Dispute, Contractor shall file with District its formal claim(s), in the form specified in this Section. For each NOPC Contractor intends to pursue as a formal claim, Contractor shall include all arguments, justification, cost or estimates, schedule analysis, and detailed documentation supporting Contractor's position. Contractor is encouraged to designate its Final Claim and Certification as its statutory claim.
- b. Claim Documentation. Contractor's Claim documentation shall conform to generally accepted auditing standards (GAAS). Contractor shall submit the Claim in the following format:
 - 1. Introduction
 - 2. General Background Discussion

3. Summary of Issues and Damages
 4. Index of Issues
 5. For Each Issue (Begin each issue on a new page)
 - a. Background
 - b. Chronology
 - c. Contractor's Position (Reason for County's potential liability)
 - d. Supporting Documentation of Merit
 - e. Supporting Documentation of Damages
 - f. Schedules (if appropriate)
 - g. Productivity exhibits (if appropriate)
- A. Contractor shall explain, cite by reference to, and/or submit photocopies of, documents supporting the merit of its position. Supporting documentation may include, but not be limited to, General Conditions, General Requirements, Technical Specifications, Drawings, correspondence, conference notes, Shop Drawings and other Submittals, Submittal Logs, survey books, inspection reports, delivery schedules, test reports, daily reports, subcontracts, fragmentary Critical Path method schedules, photographs, technical reports, Requests for Information, field instructions, and other related records necessary to support the merit of Contractor's position.
- B. Contractor shall explain, cite by reference to, and/or submit photocopies of, documents supporting damages. Supporting documentation may include, but not be limited to, any or all documents related to the preparation and submission of the Bid; Subcontractor, Supplier or vendor files and cost records; certified payroll reports, materials, equipment, and construction equipment and services costs; purchase orders; invoices; project as planned and as built costs; Subcontractor and Supplier payment documentation; quantity reports; other related records; general ledger and any other accounting materials necessary to support the Contractor's position.

K. CLAIMS SHALL BE CALCULATED IN THE SAME MANNER AS CHANGE ORDERS PER SECTION 01 26 00 (CONTRACT MODIFICATION PROCEDURES). NO SPECIAL, INCIDENTAL OR CONSEQUENTIAL DAMAGES MAY BE CLAIMED, REQUESTED OR RECOVERED.

9-1.03.03 SUBCONTRACTOR CLAIMS.

- A. Contractor shall require each Subcontractor, sub-Subcontractor and supplier to comply with the claims procedure set forth in this Document 00 73 83 to provide Contractor with timely notice and documentation of all claims. Contractor shall present as its claims, all Subcontractor, sub-Subcontractor and supplier claims of any type, and prove them under the terms of the Contract Documents. Owner shall not be directly liable to any Subcontractor, any supplier, or any other person or

organization, or to any surety for or employee or agent of any of them, for damages or extra costs of any type arising out of or resulting from the Project.

9-1.03.04 WRITTEN DECISION AND ACTION ON CLAIMS

Time frames and procedures Decisions on statutory claims and formal claims follow the same procedures stated In Public Contract Code Section 9104:

- a. “Upon receipt of a claim pursuant to this section, the District shall conduct a reasonable review of the claim and, within a period not to exceed 45 days, shall provide the claimant a written statement identifying what portion of the claim is disputed and what portion is undisputed. Upon receipt of a claim, the District and Contractor may, by mutual agreement, extend the time period provided in this subdivision.
- b. If the District needs approval from its governing body to provide the claimant a written statement identifying the disputed portion and the undisputed portion of the claim, and the District does not meet within the 45 days or within the mutually agreed to extension of time following receipt of a claim sent by registered mail or certified mail, return receipt requested, the District shall have up to three days following the next duly publicly noticed meeting of the governing body after the 45-day period, or extension, expires to provide the claimant a written statement identifying the disputed portion and the undisputed portion.
- c. If the claimant disputes the District’s written response, or if the District fails to respond to a claim issued pursuant to this section within the time prescribed, the claimant may demand in writing an informal conference to meet and confer for settlement of the issues in dispute. Upon receipt of a demand in writing sent by registered mail or certified mail, return receipt requested, the District shall schedule a meet and confer conference within 30 days for settlement of the dispute.
- d. Within 10 business days following the conclusion of the meet and confer conference, if the claim or any portion of the claim remains in dispute, the District shall provide the claimant a written statement identifying the portion of the claim that remains in dispute and the portion that is undisputed. Any payment due on an undisputed portion of the claim shall be processed and made within 60 days after the public entity issues its written statement. Any disputed portion of the claim, as identified by the Contractor in writing, shall be submitted to nonbinding mediation, with the District and the claimant sharing the associated costs equally. The District and claimant shall mutually agree to a mediator within 10 business days after the disputed portion of the claim has been identified in writing. If the parties cannot agree upon a mediator, each party shall select a mediator and those mediators shall select a qualified neutral third party to mediate with regard to the disputed portion of the claim. Each party shall bear the fees and costs charged by its respective mediator in connection with the selection of the neutral mediator. If mediation is unsuccessful, the parts of the claim remaining in dispute shall be subject to applicable procedures outside this section.
- e. For purposes of this section, mediation includes any nonbinding process, such as neutral evaluation or a dispute review board, in which an independent third party or board assists the parties in dispute resolution through negotiation or by

issuance of an evaluation. Any mediation utilized shall conform to the timeframes in this section.

- f. Unless otherwise agreed to by the District and the Contractor in writing, the mediation conducted pursuant to this section shall excuse any further obligation under Section 20104.4 of the Public Contract Code to mediate after litigation has been commenced.
- g. Failure by the District to respond to a claim from a Contractor within the time periods described in this subdivision or to otherwise meet the time requirements of this section shall result in the claim being deemed rejected in its entirety. A claim that is denied by reason of the District's failure to have responded to a claim, or its failure to otherwise meet the time requirements of this section, shall not constitute an adverse finding with regard to the merits of the claim or the responsibility or qualifications of the claimant.
- h. Amounts not paid in a timely manner as required by the negotiations required under Public Contract Code section 9204 shall bear interest at 7 percent per annum."

9-1.03.05 CLAIM UPDATES AND WAIVER

- A. Claim Updates Required. If Disputed Work persists longer than a single calendar month, then for each quarter until the Disputed Work ceases, Contractor shall submit to District a document titled "Claim Update" that shall update and quantify all elements of the Claim as completely as possible. Contractor's failure to submit a Claim Update or to quantify costs every quarter shall result in waiver of the Claim for that period. Claims or Claim Updates stating that damages, total damages (direct and indirect), schedule impact and/or any time extension will be determined at a later date shall not comply with this subparagraph and shall result in Contractor waiving its claim(s). Contractor shall also maintain a continuing "claims log" that shall list all outstanding claims and their value, and provide such log to Owner quarterly.
- B. Waiver. If the initially required notice of Dispute, Updated Dispute, Notice of Potential Claim and Final Claim, are not issued within the time period required herein, or if Contractor proceeds with the disputed Work without first having given the notice of the Disputed Work, Contractor shall be deemed to have waived its rights to further claim on the specific issue.

9-1.03.06 GOVERNMENT CODE SECTION 930.2

- A. The procedures, negotiations, record keeping, documentation and Final Claim, if negotiation efforts prove unsuccessful, as required in this Section, are intended to constitute a mandatory administrative remedy and part One of a two-step claim procedure by agreement under California Government Code Section 930.2. Step One is compliance with the Good Faith Negotiations and Claim Requirements. Step Two is filing a Government Code Section 910 Claim in with the County following statutory procedures and identifying Claims submitted, negotiated and not settled.

- B. Should Contractor fail to timely comply with the procedures set forth in this Section, Contractor may have rights to apply for consideration of late claims following the procedures in Government Code Section 930.4. This Section defines the limits of authority of District's representative to consider late claims and the basis therefore.

9-1.03.07 WAIVER AND SUBSTANTIAL COMPLIANCE

- A. If Contractor fails to comply with this Section as to any claim or Disputed Work, then Contractor shall waive its rights to such claim. All claim(s), Disputed Work items or issue(s) not raised in a timely notice, timely notice of potential claim and then timely claim submitted under this Section, may not be asserted in any subsequent arbitration (if subsequently agreed), litigation or legal action, and any award (or portion thereof), judgment or verdict contrary to this preclusion shall be vacated to the extent contrary.
- B. Contractor may request an extension of time to comply with the claims procedure herein, but must do so in advance of time periods expiring and District must give its approval in writing (which approval may be withheld in District's discretion.) As to any other feature of the claim procedure herein (and its claims waiver feature), it may not be waived or altered absent a written Change Order signed by both parties and accepted as to form by their legal counsel (for the District, the Office of the District Attorney.)
- C. The District, in its sole discretion, may consider Contractor's substantial compliance with the required initial notice and written Dispute, provided Contractor demonstrates good faith and a manifest lack of prejudice to District from late written notice, for example, contemporaneous District/Contractor discussions and review of Disputed Work with full opportunity to investigate and verify costs and work performed. Under no circumstances may substantial compliance be considered when the required written notice is more than twenty-one (21) calendar days late.
- D. The District shall not be deemed to waive or alter any provision under this Section, if at District's sole discretion; a claim is administered in a manner not in accord with this Section.
- E. Compliance with the foregoing shall not be a prerequisite to any Claim that is based solely on differences in measurement or errors of computations as to Contract quantities.

9-1.03.07 CLAIMS UNDER \$375,000

- A. The provision of Public Contract Code §20104 set seq. relating to the resolution of construction claims of three hundred seventy-five thousand dollars (\$375,000) or less which arise between a contractor and the District are hereby incorporated in this Contract and are *italicized* for ease of use.
- B. Documentation that is necessary to substantiate Claims submitted pursuant to this section must comply with the format requirements set forth in this Section.

- a. Claims for \$375,000 or below, as provided by Public Contract Code - §20104 (a)-(d), Application of article; provisions included in plans and specifications:
 - (a) (1) *This article applies to all public works claims of three hundred seventy-five thousand dollars (\$375,000) or less which arise between a contractor and local agency.*
 - (2) *This article shall not apply to any claims resulting from a contract between a contractor and a public agency when the public agency has elected to resolve any disputes pursuant to Article 7.1 (commencing with §10240) of Chapter 1 of Part 2.*
 - (b) (1) *"Public work" means "public work contract" as defined in Section 1101 but does not include any work or improvement contracted for by the state or the Regents of the University of California.*
 - (2) *"Claim" means a separate demand by the contractor for (A) a time extension, (B) payment of money or damages arising from work done by, or on behalf of, the contractor pursuant to the contract for a public work and payment of which is not otherwise expressly provided for or the claimant is not otherwise entitled to, or (C) an amount the payment of which is disputed by the local agency.*
 - (c) *The provisions of this article or a summary thereof shall be set forth in the plans or specifications for any work which may give rise to a claim under this article.*
 - (d) *This article applies only to contracts entered into on or after January 1, 1991.*

- C. Claims for \$375,000 or below, as provided by Public Contract Code - §20104.2 (a)-(f), Claims, requirements, tort claims excluded:

For any claim subject to this article, the following requirements apply:

- (a) *The claim shall be in writing and include the documents necessary to substantiate the claim. Claims must be filed on or before the date of Final Payment. Nothing in this subdivision is intended to extend the time limit or supersede notice requirements otherwise provided by contract for the filing of claims.*
- (b) (1) *For claims of less than fifty thousand dollars (\$50,000), the local agency shall respond in writing to any written claim within 45 days of receipt of the claim, or may request, in writing, within 30 days of receipt of the claim, any additional documentation supporting the claim or relating to defenses to the claim the local agency may have against the claimant.*
- (2) *If additional information is thereafter required, it shall be requested and provided pursuant to this subdivision, upon mutual agreement of the local agency and the claimant.*

(3) The local agency's written response to the claim, as further documented, shall be submitted to the claimant within 15 days after receipt of the further documentation or within a period of time no greater than that taken by the claimant in producing the additional information, whichever is greater.

(c) (1) For claims of over fifty thousand dollars (\$50,000) and less than or equal to three hundred seventy-five thousand dollars (\$375,000), the local agency shall respond in writing to all written claims within 60 days of receipt of the claim, or may request, in writing, within 30 days of receipt of the claim, any additional documentation supporting the claim or relating to defenses to the claim the local agency may have against the claimant.

(2) If additional information is thereafter required, it shall be requested and provided pursuant to this subdivision, upon mutual agreement of the local agency and the claimant.

(3) The local agency's written response to the claim, as further documented, shall be submitted to the claimant within 30 days after receipt of the further documentation, or within a period of time no greater than that taken by the claimant in producing the additional information or requested documentation, whichever is greater.

(d) If the claimant disputes the local agency's written response, or the local agency fails to respond within the time prescribed, the claimant may so notify the local agency, in writing, either within 15 days of receipt of the local agency's response or within 15 days of the local agency's failure to respond within the time prescribed, respectively, and demand an informal conference to meet and confer for settlement of the issue in dispute. Upon a demand, the local agency shall schedule a meet and confer conference within 30 days for settlement of the dispute.

(e) Following the meet and confer conference, if the claim or any portion remains in dispute, the claimant may file a claim as provided in Chapter 1 (commencing with Section 900) and Chapter 2 (commencing with Section 910) of Part 3 of Division 3.6 of Title 1 of the Government Code. For purposes of those provisions, the running of the period of time within which a claim must be filed shall be tolled from the time the claimant submits his or her written claim pursuant to subdivision (a) until the time that claim is denied as a result of the meet and confer process, including any period of time utilized by the meet and confer process.

(f) This article does not apply to tort claims and nothing in this article is intended nor shall be construed to change the time periods for filing tort claims or actions specified by Chapter 1 (commencing with Section 900) and Chapter 2 (commencing with Section 910) of Part 3 of Division 3.6 of Title 1 of the Government Code.

D. Claims for \$375,000 or below, as provided by Public Contract Code - § 20140.4(a)-(c), pertaining to Civil action procedures; mediation and arbitration; trial de novo; witnesses:

The following procedures are established for all civil actions filed to resolve claims subject to this article:

(a) *Within 60 days, but no earlier than 30 days, following the filing or responsive pleadings, the court shall submit the matter to nonbinding mediation unless waived by mutual stipulation of both parties. The mediation process shall provide for the selection within 15 days by both parties of a disinterested third person as mediator, shall be commenced within 30 days of the submittal, and shall be concluded within 15 days from the commencement of the mediation unless a time requirement is extended upon a good cause showing to the court or by stipulation of both parties. If the parties fail to select a mediator within the 15-Day period, any party may petition the court to appoint the mediator.*

(b) (1) *If the matter remains in dispute, the case shall be submitted to judicial arbitration pursuant to Chapter 2.5 (commencing with Section 1141.10) of Title 3 of Part 3 of the Code of Civil Procedure, notwithstanding Section 1141.11 of that code. The Civil Discovery Act (Title 4 commencing with Section 2016.010 of Part 4 of the Code of Civil Procedure) shall apply to any proceeding brought under this subdivision consistent with the rules pertaining to judicial arbitration.*

(2) *Notwithstanding any other provision of law, upon stipulation of the parties, arbitrators appointed for purposes of this article shall be experienced in construction law, and, upon stipulation of the parties, mediators and arbitrators shall be paid necessary and reasonable hourly rates of pay not to exceed their customary rate, and such fees and expenses shall be paid equally by the parties, except in the case of arbitration where the arbitrator, for good cause, determines a different division. In no event shall these fees or expenses be paid by state or county funds.*

(3) *In addition to Chapter 2.5 (commencing with Section 1141.10) of Title 3 of Part 3 of the Code of Civil Procedure, any party who after receiving an arbitration award requests a trial de novo but does not obtain a more favorable judgment shall, in addition to payment of costs and fees under that chapter, pay the attorney's fees of the other party arising out of the trial de novo.*

(c) *The court may, upon request by any party, order any witnesses to participate in the mediation or arbitration process.*

E. Claims for \$375,000 or below, as provided by Public Contract Code - §20140.6 (a)-(b), Payment on undisputed portion of claim; interest on arbitration awards or judgments:

(a) *No local agency shall fail to pay money as to any portion of a claim which is undisputed except as otherwise provided in the contract.*

(b) *In any suit filed under Section 20104.4, the local agency shall pay interest at the legal rate on any arbitration award or judgment. The interest shall begin to accrue on the date the suit is filed in a court of law.*

SECTION 10
SPECIAL PROVISIONS



TECHNICAL SPECIFICATIONS
(Special Provisions)
for
MEADOW VIEW EASEMENT
SEWER REHABILITATION PROJECT

August 2020

Prepared By:

A handwritten signature in black ink that reads 'Jennifer Melman'.

Jennifer Melman
RCE 62260



8/07/20

Date



1400 Neotomas Avenue
Santa Rosa, CA 95405
(707) 571-8005

SECTION 10 SPECIAL PROVISIONS

SECTION 10 - GENERAL

10-1.01 DESCRIPTION OF WORK

The work in general consists of sanitary sewer rehabilitation, including replacement of pipe by pipe bursting, replacement of mainline cleanouts, lateral reconnection and such other items of work as are required to complete the project.

The estimate of the quantities of work to be done is approximate only, being as a basis for the comparison of bids, and the District does not expressly or by implication agree that the actual amount of work will correspond therewith but reserves the right to increase or decrease the amount or any portion of the work as directed by the District Engineer.

Incidental items of construction necessary to complete the whole work in a satisfactory and acceptable manner as shown on the plans and as provided for in the specifications and not specifically referred to in this section, shall be understood to be furnished by the Contractor.

Full compensation for conforming to the requirements of this section shall be considered as included in the contract prices paid for the various contract items of work and no additional compensation will be allowed.

10-1.02 CONSTRUCTION LIMITATIONS

The Contractor will be expected to conduct his/her operations in a manner which creates a minimum damage to the natural vegetation and landscaping, paving and property improvements. Care shall be exercised to avoid hazards that may cause injury to persons, animals or property either during working hours or after work hours, which will include dust control, backfilling trenches or placement of steel plates and temporary fencing as required.

Equipment will be restricted to the immediate area of construction and trenches will be backfilled as soon as possible.

Receptacles for construction residue, including oil, cleaning fluids and litter, will be covered. Such residues shall be disposed of in a timely and proper manner.

Mufflers and/or baffles will be required on all construction equipment.

Construction activity within the existing right-of-way will be scheduled to minimize traffic inconvenience and safety hazards to motorists, pedestrians and cyclists.

Full compensation for conforming to the requirements of this section shall be considered as included in the contract prices paid for the various contract items of work and no additional compensation will be allowed.

10-1.03 ORDER OF WORK

Order of work shall be in accordance with Section 5, "Control of Work," of the Standard Specifications and these Special Provisions.

Attention is directed to "Temporary Traffic Control" of these Special Provisions.

Full compensation for conforming to the requirements of this section shall be considered as included in the contract prices paid for the various contract items of work and no additional compensation will be allowed.

10-1.04 STORM WATER POLLUTION PREVENTION

Attention is directed to the provisions in Section 13, "Water Pollution Control," of the Standard Specifications and these Special Provisions.

The Contractor shall exercise every reasonable precaution to protect streams, lakes, reservoirs, bays, and coastal waters from pollution with fuels, oils, bitumens, calcium chloride and other harmful materials and shall conduct and schedule his operations so as to avoid or minimize muddying and silting of said streams, lakes, reservoirs, bays and coastal waters. Care shall be exercised to preserve roadside vegetation beyond the limits of construction.

Water pollution control work is intended to provide prevention, control and abatement of water pollution to streams, waterways, and other bodies of water, and shall consist of constructing those facilities which may be shown on the plans, specified herein or in the special provisions, or directed by the Engineer.

Before starting any work on the project, the Contractor shall submit, for acceptance by the District Engineer, a program to control water pollution effectively during construction of the project. Such program shall show the schedule for the erosion control work included in the contract and for all water pollution control measures which the Contractor proposes to take in connection with construction of the project to minimize the effects of his operation upon adjacent streams and other bodies of water. The Contractor shall not perform any clearing and grubbing or earthwork on the project, other than that specifically authorized in writing by the Engineer, until such program has been accepted.

The District Engineer will notify the Contractor of the acceptance or rejection of any submitted or revised water pollution control program within 5 working days.

Full compensation for conforming to the requirements of this section shall be considered as included in the contract prices paid for the various contract items of work and no additional compensation will be allowed.

10-1.05 TEMPORARY EROSION CONTROL

Temporary erosion control shall consist of, but not be limited to, constructing such facilities and taking such measures as are necessary to prevent, control and abate water, mud, and erosion damage to public and private property as a result of the construction of this project.

Conformance with the requirements of this section shall in no way relieve the Contractor from his responsibilities, as provided in Section 13-6, "Temporary Sediment Control," Section 5-1.36, "Property and Facility Preservation," and Section 5-1.39, "Damage Repair and Restoration," of the Standard Specifications.

Temporary erosion control features as are necessary to prevent damage during the winter season shall be constructed and functioning. The Contractor shall construct such supplementary temporary erosion control facilities as are necessary to protect adjacent private and public property.

Temporary erosion control measures shall conform to the current edition of ABAG manual of standards for erosion and sediment control measures and includes, but not limited to the following:

- A. The Contractor shall conduct his/her operations in such a manner that storm runoff will be contained within the project or channeled into the storm drain system which serves the runoff area. Storm runoff from one area shall not be allowed to divert to another runoff area.
- B. The roadway and sidewalks shall be kept swept, and spoils from sawcutting, trenching, etc. and silt, shall be removed daily or as often as needed to prevent spoils and silt from entering the storm drain system and creeks.

Full compensation for conforming to the requirements of this section shall be considered as included in the contract prices paid for the various contract items of work and no additional compensation will be allowed.

10-1.06 PUBLIC SAFETY

The Contractor shall at all times conduct his/her work in accordance with Construction Safety Orders of the Division of Industrial Safety, State of California, to ensure the least possible obstruction to traffic and inconvenience to the general public, and adequate protection of persons and property in the vicinity of the work.

No access way shall be closed to the public without first obtaining permission of the Engineer.

Should the Contractor fail to provide public safety as specified or if, in the opinion of the Engineer, the warning devices furnished by the Contractor are not adequate, the District may place any warning lights or barricades or take any necessary action to protect or warn the public of any dangerous condition connected with the Contractor's operations and the Contractor shall be liable to the District for all costs incurred including, but not limited to, administrative costs.

Nothing in this section shall be construed to impose tort liability on the District or Engineer.

Full compensation for conforming to the requirements of this section shall be considered as included in the contract prices paid for the various contract items of work and no additional compensation will be allowed.

10-1.07 WATER FOR CONSTRUCTION AND DUST CONTROL

Construction and testing water shall conform to Section 17, "Watering," of the Standard Specifications and these Special Provisions. The Contractor shall be responsible for providing all water necessary for construction and testing and disposing of all water needed for testing.

During the performance of the work called for under these Specifications, or any operations appurtenant thereto, the Contractor shall furnish all labor, equipment and means required, and as often as necessary, to prevent his operations from producing dust in amounts damaging to property or causing a nuisance to persons living nearby or occupying buildings in the vicinity.

The Contractor may use fire hydrants with temporary meters obtained from District to supply water. The Contractor will be required to complete a hydrant meter application and obtain a fire hydrant flow meter and will be responsible for paying all applicable deposits and fees for use of the meter and water. The Contractor may obtain a fire hydrant flow meter at the District office located at 19400 Hartmann Rd, Hidden Valley Lake, CA, 95467.

Full compensation for conforming to the requirements of this section shall be considered as included in the contract prices paid for the various contract items of work and no additional compensation will be allowed.

10-1.08 PROTECTION OF EXISTING FACILITIES AND PROPERTY

The Contractor shall notify Underground Service Alert (USA) for marking the locations of existing underground facilities.

The Contractor shall take all necessary measures to avoid injury to existing surface and underground utility facilities in and near the site of the work. No error or omission of utility markouts shall be construed to relieve the Contractor from his responsibility to protect all underground pipes, conduits, cables or other structures. The Contractor shall indemnify the District and hold it harmless from any and all claims, demands, or liability made or asserted by any person or entity on account of or in connection with any damage to such surface or underground facilities caused by the Contractor or any of his agents or subcontractors.

The existing underground facilities in the area of work may include water mains, sewer pipe and drainage pipe. The various utility companies shall be notified before trenching begins and at such other times as required to protect their facilities. Underground facilities shall be located and exposed in accordance with the requirements of Section 13-1.04 in advance of trenching to prevent damage to the facilities, and to determine the depth and character of all facilities that cross or infringe on the trench prism and pipe bursting pit. The Contractor shall immediately notify the District Engineer of any facilities found. If damage should occur to the existing facilities, the utility company and the District shall be notified immediately and repairs acceptable to the utility company shall be made at the Contractor's expense. Contractor shall protect existing utility markers and remove and replace markers as required.

The Contractor shall preserve and protect District survey monuments and benchmarks per State of California Business and Professions Code Section 8771.

Attention is directed to the provisions in Section 5-1.36, "Property and Facility Preservation," of the Standard Specifications, which section is hereby incorporated in these special provisions as if set forth in full, and these Special Provisions.

Existing trees, shrubs, and other plants, that are not to be removed and are injured or damaged by reason of the Contractor's operations, shall be replaced by the Contractor in accordance with the requirements in Section 20-7.03I(16), "Replacement Plants," of the Standard Specifications. Section 20-7.03 of the Standard Specifications is hereby incorporated in these Special Provisions.

Full compensation for conforming to the requirements of this section shall be considered as included in the contract prices paid for the various contract items of work and no additional compensation will be allowed.

10-1.09 OBSTRUCTIONS

Attention is directed to Sections 5-1.36D, "Non-highway Facilities," and 15, "Existing Facilities," of the Standard Specifications, which sections are hereby incorporated in these Special Provisions as if set forth in full, and these Special Provisions.

Attention is directed to the existence of overhead power, telephone, and television cable, and/or fiber optic cables, underground sewer mains and laterals, and underground water mains and laterals within the area in which construction is to be performed.

Prior to starting work, the Contractor shall (a minimum of 2 working days in advance) call Underground Service Alert (USA), toll free, at (800) 227-2600 or 811 and provide USA with all necessary data relative to the proposed work. USA will accept calls and process information to participating agencies who have underground facilities in the area between the hours of 7:30 a.m. and 5:00 p.m. daily, except Saturdays, Sundays, and holidays. Between the hours of 5:00 p.m. and 7:30 a.m. calls will be recorded and then processed after 7:30 a.m. For emergency situations,

after hours and on Saturdays, Sundays and holidays, the Contractor shall contact the organization owning the affected facility. Upon notification, agencies having facilities in the area of the proposed excavation will mark their locations in the field using USA standard colors and codes to identify the facility.

Any delays claimed by the Contractor as a direct result of the utility facilities not being rearranged as provided will not be recognized nor will any delays be considered right-of-way delays within the meaning of Section 8-1.07, "Delays," of the Standard Specifications, except that any such delays will entitle the Contractor to an extension of time as provided in Section 8-1.10, "Liquidated Damages," of the Standard Specifications. The Contractor shall immediately notify the Engineer of such delays.

The Contractor will be required to work around public and private utility facilities and other improvements that are to remain in place within the construction area and he will be held liable to the owners of such facilities or interference with service resulting from his operations.

Full compensation for conforming to the requirements of this section shall be considered as included in the contract prices paid for the various contract items of work and no additional compensation will be allowed.

10-1.10 HOURS OF WORK

The Contractor shall restrict his hours of work to 8:00 a.m. to 5:00 p.m. Monday through Friday. Deviations from these hours may be requested and approved in writing by the Engineer.

10-1.11 DUST CONTROL

Dust control shall conform to the provisions in Section 14-9.03, "Dust Control," of the Standard Specifications, which section is hereby incorporated in these special provisions as if set forth in full, and these Special Provisions.

Full compensation for conforming to the requirements of this section shall be considered as included in the contract prices paid for the various contract items of work and no additional compensation will be allowed.

10-1.12 PRECONSTRUCTION CONFERENCE

Prior to beginning any work, the Contractor shall provide the Engineer and affected agencies with a list of key and responsible personnel and how they may be reached at any time. A preconstruction conference shall be scheduled at least one calendar week prior to construction, at which time the Contractor shall be required to present his proposed work schedule, information of offsite yards, subcontractors, location of disposal and stockpile areas, and to review the previously submitted traffic control plans. All such schedules shall be subject to the approval of the Engineer and the applicable agencies.

Full compensation for conforming to the requirements of this section shall be considered as included in the contract prices paid for the various contract items of work and no additional compensation will be allowed.

10-1.13 REFERENCED SPECIFICATIONS AND STANDARDS

All contract work will be in accordance with the District Standards, all other terms of this contract including, but not limited to, these Special Provisions, and applicable law. Provisions of the State Standards and the Standard Specifications will only apply to and be a part of this contract to the extent such provisions are expressly incorporated in these Special Provisions.

10-1.14 OWNER NOTIFICATION

The Contractor shall notify all property owners affected by the project's work at least 72 hours before work is to begin. The notice shall be in writing, placed on doors and shall indicate the Contractor's name and phone number, type of work, day(s) and time when work will occur. Notice shall be reviewed by the Engineer prior to being posted.

Parking restrictions shall be posted 48 hours in advance along the affected construction areas. See Section 12-1.06 "Removal of On-Street Parking" of these Special Provisions.

Full compensation for conforming to the requirements of this section shall be considered as included in the contract prices paid for the various contract items of work and no additional compensation will be allowed.

10-1.15 EMERGENCY SERVICE PROVIDERS NOTIFICATIONS

The Contractor shall furnish the name and phone number of a representative that can be contacted in the event of an emergency. Said information shall be reported to the Lake County Sheriff's dispatcher and updated as required to provide 24-hour phone access.

Full compensation for conforming to the requirements of this section shall be considered as included in the contract prices paid for the various contract items of work and no additional compensation will be allowed.

10-1.16 CLEANUP

Attention is directed to Section 4-1.13, "Cleanup," of the Standard Specifications, which section is hereby incorporated in these Special Provision as if set forth in full.

Before final inspection of the work, the Contractor shall clean the construction site and all ground occupied by him in connection with the work, of all rubbish, excess material, falsework, temporary structures and equipment. All parts of the work shall be left in a neat and presentable condition.

Nothing herein shall require the Contractor to remove warning, regulatory, and guide signs prior to formal acceptance by the Engineer.

Full compensation for conforming to the requirements of this section shall be considered as included in the contract prices paid for the various contract items of work and no additional compensation will be allowed.

10-1.17 TESTS AND INSPECTIONS

Attention is directed to Section 3-1.03 of the General Provisions for information on materials testing and inspections.

Full compensation for conforming to the requirements of this section shall be considered as included in the contract prices paid for the various contract items of work and no additional compensation will be allowed.

10-1.18 CONSTRUCTION STAKING

Attention is directed to Section 3-1.11 of the General Provisions for information on Construction Staking.

Full compensation for conforming to the requirements of this section shall be considered as included in the contract prices paid for the various contract items of work and no additional compensation will be allowed.

10-1.19 CONTRACTOR STAGING AREA

Contractor shall not utilize public streets or parking spaces for overnight or weekend storage of vehicles, equipment or materials unless approved by the Engineer. All paved surfaces shall be broom clean at the completion of construction.

Full compensation for conforming to the requirements of this section shall be considered as included in the contract prices paid for the various contract items of work and no additional compensation will be allowed.

10-1.20 MOBILIZATION AND DEMOBILIZATION

Mobilization and demobilization shall consist of preparatory work and operations, including, but not limited to, those necessary for the movement of personnel, equipment, supplies and incidentals to and from the project site; for establishment and removal of all facilities necessary for work on the project; and for all other work and operations which must be performed or costs incurred prior to beginning and after completing work on the various contract items on the project site.

Mobilization and Demobilization shall be paid in at the contract Lump Sum price for all that which is necessary for this item and shall not exceed 5 percent of total bid price and shall include payment for obtaining all bonds, all Contractor acquired permits, licenses, agreements, certifications, notices of intent, and temporary easements; furnishing, moving onto the site of all equipment, materials and staff including set up of Contractor's staging area/yard; furnishing and erecting all needed construction facilities, fencing, project security, demobilization, punchlist, and all work as required for the proper performance and completion of the project, including preconstruction photographs, video recording of surface features, progress schedules and reports, contract meetings, and record drawings. Mobilization and Demobilization is eligible for partial payment under California Public Contract Code Section 10264.

SECTION 11 - TEMPORARY TRAFFIC CONTROL

11-1.01 CONSTRUCTION AREA SIGNS

Temporary construction area signs are required for the direction of public vehicle and pedestrian traffic through or around the work during construction.

Construction area signs shall be furnished, installed, maintained and removed when no longer required in accordance with the provisions in Section 12, "Temporary Traffic Control," of the Standard Specifications and these Special Provisions. Sections 7-1.03, "Public Convenience," and 7-1.04, "Public Safety," of the Standard Specifications set forth the Contractor's responsibilities for public convenience and public safety are hereby incorporated in these Special Provisions as if set forth in full and are considered to be part of the contract requirements.

Construction area signs shall not be used until they are needed and when no longer needed they shall be removed from the site of the work.

11-1.02 MAINTAINING TRAFFIC

Attention is directed to Section 7-1.03, "Public Convenience," Section 7-1.04, "Public Safety," and Section 12 "Temporary Traffic Control," of the Standard Specifications, which sections are hereby incorporated in these Special Provisions as if set forth in full. Nothing in these Special Provisions shall be construed as relieving the Contractor from his responsibilities as provided in said Section 7-1.04.

11-1.03 MAINTAINING TRAFFIC AND PEDESTRIAN OPERATIONS

The site of the work shall be enclosed by suitable barricades, signs and lights to warn and protect traffic effectively and shall be in accordance with those procedures as set by the Federal Highway Administration.

The Contractor shall provide adequate barricades, signs, warning lights, watchmen and flagmen in accordance with the latest revision of the State of California "Manual for Warning Signs, Lights and Devices for Use in Performing Work Upon Highways" to protect the work and the safety of the public. Warning lights using inflammable liquids will not be permitted; only electrically operated lights will be approved for use. Warning lights shall be kept burning from sunset to sunrise, and barricades shall be painted to increase their visibility at night.

All traffic control shall be between 8:00 a.m. and 5:00 p.m.; unobstructed two-way traffic shall be maintained daily from 5:00 p.m. to 8:00 a.m.

Attention is directed to Section 7-1.03, "Public Convenience," and Section 7-1.04, "Public Safety," of the Standard Specifications, which sections are hereby incorporated in these Special Provisions as if set forth in full. Attention is also directed to Section 10-1.07, "Public Safety," of these Special Provisions.

Adequate traffic control, flagmen, signing, and barricades shall be provided by the Contractor at all times as approved by the Engineer.

11-1.04 TRAFFIC CONTROL PLAN

It is the responsibility of the Contractor shall submit a Traffic Control Plan ten (10) working days prior to beginning construction. Work shall not begin until the plan is approved by the Engineer.

The content of the Traffic Control Plan shall include, but not be limited to, the following:

- A. Show location and limits of the work zone.

- B. Give dimensions of lanes affected by traffic control that will be open to traffic.
- C. Indicate signing, cone placement, and other methods of delineation and reference to appropriate District or Caltrans standard.
- D. Dimension location of signs and cone tapers.
- E. Identify side streets and driveways affected by construction and show how they will be handled.
- F. Show how pedestrian traffic will be handled through the construction site.
- G. Demonstrate how one-way traffic will be maintained.

No work except for the installation of project identification signage will be allowed to commence prior to approval of the work zone Traffic Control Plan.

11-1.05 REMOVAL OF ON-STREET PARKING

Forty-eight (48) hours prior to construction, the Contractor shall place barricades signed “NO PARKING –TOW AWAY – Specific Time and Date(s)” at 100-foot intervals or a minimum of 2 signs per block, whichever is greater, in the work area. “NO PARKING” signs must also state “C.V.C. 22651 (L)”. See example below.

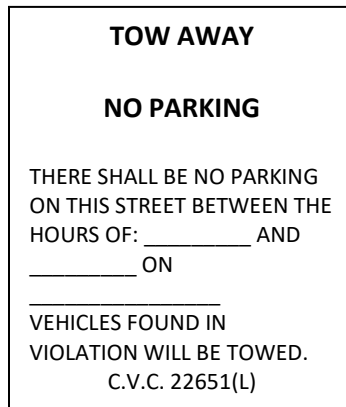

“NO PARKING – TOW AWAY” signs shall be submitted for approval by the Engineer prior to their use. The Contractor shall notify the Engineer immediately after the “NO PARKING” signs are in place. “NO PARKING” signs and barricades shall be supplied by the Contractor.

Failure to comply with this section will prevent the District from towing vehicles parked in the proposed work area. Any resulting delay will be the responsibility and at the expense of the Contractor. Section 12-1.03, “Flagging Costs,” of the Standard Specifications is hereby incorporated in these Special Provisions as if set forth in full and is amended to read:

The total cost of furnishing all flaggers will be borne solely by the Contractor.

11-1.06 MEASUREMENT AND PAYMENT

All work associated with Temporary Traffic Control, including but not limited to Construction Area Signs, Maintaining Traffic, Maintaining Traffic and Pedestrian Operations, Traffic Control Plan and Removal of On-street Parking shall be paid at the contract Lump Sum price for all that which is necessary for this item and shall be full compensation for furnishing all labor (including flagging costs), materials (including signs, barricades, lighted arrow boards, detours), Detour Plan, Traffic Control Plan, Pedestrian Control Plan, lighting, pedestrian and traffic ramps, temporary striping, permanent striping, pavement markers, tools, equipment, and incidentals and for doing all the work involved in placing, removing, storing, maintaining, and moving to new locations, replacing,

and disposing of the components of the traffic control system as specified in the Standard Specifications and these Special Provisions, and as directed by the Engineer.

SECTION 12 - WATER POLLUTION CONTROL

12-1.01 WATER POLLUTION CONTROL

Water pollution control shall conform to the requirements in Section 13, "Water Pollution Control," of the Caltrans Specifications, these Special Provisions, and as directed by the Engineer.

The Contractor shall develop and implement a Water Pollution Control Program (WPCP), which specifies Best Management Practices (BMPs) that will prevent all construction pollutants from contacting storm water and with the intent of keeping all products of erosion from moving off site into receiving waters. The Contractor shall inspect and maintain all BMPs.

12-1.02 EXCAVATION DEWATERING

The Contractor is advised that groundwater may be present in the proposed excavation, particularly closer to Deer Hill Road. As necessary, the Contractor shall keep excavations free from water during construction. Groundwater shall be collected in temporary storage tanks for settling, filtration, and testing prior to discharge.

The Contractor shall develop an excavation dewatering plan in accordance with this Section. The Contractor shall qualitatively monitor for odor or visual discrepancies indicative of hydrocarbon contamination in groundwater during dewatering operations. The Contractor shall notify the Engineer immediately if potential contamination is encountered.

A. Discharge to Collection System

1. The Contractor shall coordinate groundwater discharge into the collection system with the District, including verifying water quality requirements, discharge flow limitations into the collection system, and location of discharges into the collection system. Discharged flows into the collection system is contingent on available sewer system capacity as determined by the District. In no case shall the Contractor's groundwater disposal operation surcharge the collection system (i.e., full pipe flow).
2. If the project site has known contamination, the Contractor must contact the Engineer for additional monitoring and pre-treatment requirements prior to the commencement of the project.

- B. The Contractor is responsible for designing, constructing, operating and maintaining all necessary features to complete the work including furnishing, installing and maintaining all pumping and other equipment required to dewater any trenches containing water as may be encountered during performance of the work. The dewatering plan shall be submitted to and approved by the Engineer prior to implementation. The design and operation of the system shall: prevent instability or loss of soil as water is removed; avoid inducing settlement or damage to existing facilities, completed work or adjacent property; and relieve artesian pressures and the resultant uplift of the excavation bottom. At the permanent conclusion of dewatering operations, all dewatering equipment shall be removed from the job site.

12-1.03 MEASUREMENT AND PAYMENT

No separate measurement or payment will be made for conforming to the requirements of this section. Full compensation shall be considered as included in the contract prices paid for the various contract items of work and no additional compensation will be allowed.

SECTION 13 - EXISTING FACILITIES

13-1.01 GENERAL

The work performed in connection with various existing highway facilities shall conform to the provisions in Section 15, "Existing Facilities," of the Standard Specifications and these Special Provisions.

13-1.02 REMOVAL OF MISCELLANEOUS ITEMS

Various items shown on the Plans to be removed will be completely removed and disposed of.

No separate payment shall be made for the various items to be removed unless specified and listed in the Bid Schedule.

Full compensation for conforming to the requirements of this section shall be considered as included in the contract prices paid for the various contract items of work and no additional compensation will be allowed.

13-1.03 SAWCUT AND REMOVE PAVEMENT

Where no joint exists in concrete or asphalt concrete to be removed and concrete or asphalt concrete to remain in place, the concrete or asphalt concrete shall be cut in neat lines to a minimum depth of 0.17 foot with a power-driven saw before the concrete or asphalt concrete is removed.

Full compensation for sawcutting and removal of pavement shall be considered as included in the contract prices paid for the various contract items of work requiring sawcutting and removal of pavement and no additional compensation will be allowed.

13-1.04 UTILITY POTHOLING

All items noted in this Section shall take place prior to any other construction activities at any potential conflict.

Prior to beginning work, the Contractor shall pothole or otherwise physically determine the actual horizontal location, size and vertical depth of buried utilities and other man-made objects throughout the proposed area of work, check for conflicts, and provide the pothole data and written notice of any suspected conflicts between existing and proposed facilities to the Engineer. The Contractor shall pothole all potentially conflicting utilities 10 working days prior to the start of excavation in a construction area. Said pothole data and written notice shall be provided to the Engineer not less than 5 days prior to beginning any such excavation. Existing utilities shown on the plans are for general information only. All utilities shall be retained and protected, unless otherwise noted on the plans.

Any delay in notification to the Engineer may delay direction and/or corrective action and a delay claim due to this reason will not be considered by the District. The Contractor shall not proceed with any work that is in conflict until direction is provided by the Engineer and shall redirect crews to other contract work. All the information required to be obtained per this section, and any other information not noted but relative to the project, shall be provided to the Engineer on a set of Plans when the investigative effort is complete.

The Contractor shall coordinate with utility providers for any necessary relocation as determined by the Engineer. The Contractor will not be compensated for any delays resulting from utility relocations and should schedule work accordingly.

Full compensation for utility potholing shall be considered as included in the contract prices paid for the various contract items of work requiring utility potholing and no additional compensation will be allowed.

13-1.05 REMOVE AND REPLACE EXISTING IMPROVEMENTS

Any improvements on private property, including landscaping, hardscaping, or pavement, that are impacted by construction activities shall be removed and relocated, or replaced in kind to the satisfaction of the District. Any damage to existing improvements shall be repaired or replaced in kind to the satisfaction of the District.

Full compensation for conforming to the requirements of this section shall be considered as included in the contract prices paid for the various contract items of work and no additional compensation will be allowed.

SECTION 14 - ROADWAY

14-1.01 AGGREGATE BASE

Aggregate base shall be Class 2, 3/4" maximum gradation conforming to and placed in accordance with the provisions in Section 26, "Aggregate Bases," of the Standard Specifications and these Special Provisions.

Compaction shall commence immediately after spreading of the damp material and before the material has dried sufficiently to allow separation between the fine and coarse particles. If the Engineer determines that the aggregate base has dried excessively before compaction can be achieved, the aggregate base shall be removed and replaced, or moisture conditioned prior to resumption of compaction effort at the Engineer's direction and the Contractor's expense.

The minimum sand equivalent shall be 31 for any individual test.

The surface of the finished aggregate base shall be firm and unyielding. Any visible movement vertically or horizontally of the aggregate base under the action of construction equipment or other maximum legal axle loads shall be considered as evidence that the aggregate base does not meet this requirement.

Full compensation for conforming to the requirements of this section shall be considered as included in the contract prices paid for the various contract items of work and no additional compensation will be allowed.

14-1.02 ASPHALT CONCRETE TRENCH PAVING

Asphalt concrete trench paving and the placing thereof shall conform to the requirements of Section 39, "Hot Mix Asphalt," of the Standard Specifications with the following modifications:

Aggregate shall be Type A, 3/4" maximum, medium for the asphalt concrete base. Aggregate shall be Type A, 1/2" maximum, medium for the asphalt concrete surface.

Paving asphalt shall be PG 64-10 conforming to the latest published provisions in Section 92, "Asphalts," of the Standard Specifications.

The Contractor shall furnish the District's Engineer, at least ten (10) working days prior to the start of work, a list of sources of materials together with a Certificate of Compliance indicating that materials to be incorporated in the work fulfill the requirements of these specifications and a mix design for the asphalt concrete. The mix design shall be performed in accordance with CTM 366 and 367. The Certificate of Compliance shall be signed by the material supplier or his representative. The Contractor shall be responsible for all costs associated with the required mix design.

A tack coat, type SS-1, shall be applied to all mating surfaces along lip of gutter and at conforms to existing pavement prior to placement of new asphalt concrete and shall conform to Section 94, "Asphaltic Emulsions" of the Standard Specifications.

Asphalt thickness for final asphalt surfacing shall conform to District Standard 502 or as shown on the Plans.

When trench width is three feet or less, the asphalt concrete used for trench paving may be deposited directly from the haul vehicle into the trench. The asphalt shall then be raked smooth prior to compaction.

The Contractor shall provide compaction of backfill and base material as the job progresses, each day. If trench cannot be paved the same day as backfill is completed, the trench shall be covered with skid resistant steel plates (with a coefficient of friction of 0.35 or greater per CTM342), capable of sustaining normal (H2O) traffic loads without shifting or bouncing. Temporary asphalt concrete paving shall be placed and compacted around all edges of steel plates to provide a smooth transition to existing pavement.

Construction shall be in accordance with Section 39-3 "Method Construction Process" of the Standard Specifications. Asphalt concrete shall be compacted to 91-97% of maximum theoretical density (CT 309) as determined by CT 375 (a nuclear density device may be used). A profilograph will not be required.

Permanent asphalt concrete trench paving shall be even, smooth riding and have an appearance that is compatible with the surrounding surface. No permanent trench paving will be done until the District has given clearance that video inspection of the sewer is acceptable.

Full compensation for conforming to the requirements of this section shall be considered as included in the contract prices paid for the various contract items of work and no additional compensation will be allowed.

14-1.03 TRENCH EXCAVATION, BACKFILL AND RESURFACING

Conform to the provisions in Section 19-3 of the Standard Specifications, District Standards and the details shown on the Plans. All backfill material shall be approved by the Engineer.

Ground water may be encountered in excavations. Ground water removal methods are subject to approval of the Engineer. Free water shall be removed from trenches prior to rehabilitating pipe.

Pipe bedding from the bottom of the trench to the bottom of the pipe shall be compacted by hand tamping to a minimum of 95% relative compaction. Bedding from the bottom of the pipe to 12" above the top of the pipe shall be compacted by hand tamping to a minimum of 95% relative compaction. All backfilling shall conform to the details shown on the Plans.

Sewer main reconstruction shall include bedding material and Class 2 aggregate base backfill where required in the contract price per linear foot.

All raised pavement markers, striping, bars or any other traffic markings disturbed during this contract work shall be replaced in kind by the Contractor to the satisfaction of the Engineer.

Full compensation for conforming to the requirements of this section shall be considered as included in the contract prices paid for the various contract items of work and no additional compensation will be allowed.

14-1.04 CONTROLLED DENSITY FILL

As an alternative to using Class 2 material for backfilling any trenches, Controlled Density Fill (CDF) material may be used. If CDF is used, it shall conform to the following:

- A. CDF or controlled low strength material (CLSM) shall be manufactured in accordance with the following referenced standards.
- B. It shall be a hand-excavatable mixture of aggregate, cement, pozzolan, water and admixtures to be used as fill material where indicated in this specification and on the drawings.
- C. CDF shall meet the requirements of Section 201-6 of the APWA Standard Specifications for Public Works Construction.

- D. CDF material shall have the following properties:
1. Cement shall be Type II in accordance with ASTM C150.
 2. Pozzolan shall be Type F in accordance with ASTM C618.
 3. Coarse aggregate
 - a) Shall consist of a well-graded mixture of crushed rock, soil, or sand with a maximum size aggregate of 3/8 inch.
 - b) One hundred percent shall pass the 1/2-inch sieve.
 - c) Not more than 30 percent shall be retained by the 3/8-inch sieve and not more than 12 percent shall pass the No. 200 sieve.
 - d) All material shall be free from organic matter and not contain more alkali, sulfates or salts than the native soils at the site of the work.
 4. Air entraining shall be used to improve the workability of the mixture in accordance with ASTM C260. Entrained air content shall be between 8 and 20 percent.
 5. Water reducing agent shall be added to improve the workability and shall be in accordance with ASTM C494.
 6. Water shall be potable, clean and free from objectionable quantities of silty organic matter, alkali, salts and other impurities.
 7. CDF shall be a flowable material similar in all respects to Pozzolanic International Flowable Compacting Fill by RMC Lonestar, or equal. The 28-day compressive strength shall be between 50 and 100 psi.
 8. CDF that has a 28-day compressive strength in excess of 100 psi shall be removed as directed by the Construction Manager and replaced with CDF meeting the specifications at no additional cost to the Owner.
 9. Contractor shall take and test field samples of CDF as directed by the Engineer, when poured/installed in the field to ensure that the strength characteristics are met.
 - a) Placement of backfill on top of CDF shall not be allowed until the CDF passes the ball drop test of ASTM D6024.
- E. Full compensation for conforming to the requirements of this section shall be considered as included in the contract prices paid for the various contract items of work and no additional compensation will be allowed.

SECTION 15 - SHEETING, SHORING AND BRACING

15-1.01 GENERAL

Trench shoring and bracing shall conform to the provisions of Cal-OSHA and the Division of Industrial Safety Orders.

This section applies to any person doing work in accordance with any permit issued by the District.

15-1.02 CONSTRUCTION

The Contractor shall obtain any necessary permits from the State of California, Division of Industrial Safety. The Contractor shall pay all costs in connection with said permits and proof of such permits shall be submitted to the Engineer prior to commencing trench work.

15-1.03 GENERAL DESIGN REQUIREMENTS

Design excavation support systems to meet requirements and standards of the Occupational Safety and Health Administration (OSHA).

Design excavation support systems to meet the requirements of California Code of Regulations, Title 8 – Construction Safety Orders and California Labor Code Sections 6705 to 6707.

Design structural steel members in accordance with the American Institute of Steel Construction (AISC) Manual of Steel Construction Allowable Stress Design and the Uniform Building Code.

Excavation support systems for trench excavations shall be selected by the Contractor based on the soil conditions, depths of trench excavations, groundwater conditions and other site conditions. No attempt has been made by Engineer to define acceptable trench shoring options.

Excavation Support System shall prevent running, caving, raveling, and sloughing of excavation walls and associated loss of adjacent ground.

Shoring and bracing systems shall be designed to assure worker safety and optimal conditions for pipe installation and minimize damage to adjacent pavement utilities.

Allowable Deflection: No more than 1/2-inch at any point on the shoring system.

15-1.04 PERFORMANCE CRITERIA

The Contractor shall be solely responsible for, and bear the sole burden of cost for, any and all damages resulting from improper shoring or failure to shore.

The safety of workmen, the protection of adjacent structures, property and utilities, and the installation of adequate supports for all excavations shall be the sole responsibility of the Contractor.

The design, planning, installation, and removal, of all shoring shall be accomplished in such a manner as to maintain stability of the required excavation and to prevent movement of soil and rock that may cause damage to adjacent shoring systems, structures, and utilities, damage or delay the work, or endanger life and health.

If a moveable trench shield is used during excavation operations widen the trench width so that the shield is free to be lifted and then moved longitudinally without binding against the trench sidewalls.

15-1.05 GEOTECHNICAL INFORMATION

Contractors, as bidders, are expected to make personal inspection of the site and otherwise satisfy themselves as to the conditions affecting the work as detailed in these Contract Documents. The bidder shall make his own deductions and conclusions as to the nature of the materials to be excavated, the difficulties making and maintaining the required excavations, the difficulties which may arise from subsurface conditions and of doing any work affected by the subsurface conditions and shall accept full responsibility therefor.

15-1.06 SUBMITTALS

A copy of Contractors' annual trench and/or excavation permit issued by State Division of Occupational Safety and Health must be provided to the District prior to the start of work.

If required by OSHA regulations, a detailed shoring and bracing plan signed by a civil or structural Engineer registered in the State of California must be provided to the District prior to the start of work.

Review of the shoring and bracing plans by the Engineer in no way relieves the Contractor from complete responsibility for providing effective and safe shoring and bracing systems.

15-1.07 INSTALLATION AND REMOVAL

Excavate only as much as can safely stand unsupported prior to installing shoring, but in no case more than 4 feet shall be left unsupported at any time. Install lagging immediately after excavation.

All shoring and bracing shall be completely removed. Removal of shoring shall:

- Be performed in step with backfilling sequence (shoring should not be removed ahead of backfilling).
- Not cause loosening or shifting of backfill, particularly within the pipe embedment material.
- Not cause damage to finished pipeline, structures, pavements, or other utilities.
- Any void space created by shoring should be completely filled with CDF.

15-1.08 MEASUREMENT AND PAYMENT

Sheeting, Shoring and Bracing shall be paid in at the contract Lump Sum price for all that which is necessary for this item and shall be full compensation for designing, installing, maintaining, and removing shoring and bracing systems as specified on the plans and these special Provisions and no additional compensation will be allowed.

SECTION 16 - CLEANING AND CCTV INSPECTIONS OF SANITARY SEWER

16-1.01 GENERAL

- A. The television inspection shall be in accordance with these Special Provisions. The Contractor shall hire an independent television inspection service to perform the closed-circuit television inspection.
- B. All sewers to be replaced by pipe bursting shall be cleaned and visually inspected by means of closed-circuit television (CCTV) and video recorded prior to construction to assure that existing pipe conditions are acceptable for the rehabilitation method, to locate and verify size of all active and inactive service line connections, insure proper installation, and locate other points of significance such as locations of: unusual conditions, roots, sags, storm gravity pipe connections, and broken pipe shall be noted.
- C. It is required that sewage flows be maintained. The operations of the Contractor shall not result in the interruption of sewage service to any customers of the District. Sewage must be controlled in a pipeline at all times and flows or leaks in the street or open ditches will not be allowed.
- D. The Contractor shall provide whatever equipment, materials and services are necessary to see that service is continuously maintained, including the installation of temporary lines, temporary pumping equipment, and night or other overtime work.
- E. When sanitary sewer main reconstruction has been completed and inspected, except as otherwise noted in these Special Provisions, the Contractor shall notify the Engineer in writing 2 working days in advance of the date for television inspection. The Engineer or their authorized representative shall be given the opportunity to be present during the inspection. Upon receipt of the completed televising inspection video discs and written logs, the Engineer requires 7 working days to review the video records and logs before giving written notice of acceptance and/or deficiencies of the lines to the Contractor.
- F. This section is intended to provide the Contractor with general guidelines. It is the Contractor's responsibility to supply all labor, materials, equipment, and apparatus not specifically mentioned herein or noted on the Plans, but which are incidental and necessary to complete the specified work.

16-1.02 SUBMITTALS

- A. The Contractor shall supply plans and specifications for this work to the televising contractor with manhole numbers, street names, addresses and any other information required to facilitate the work.
- B. Submit description of cleaning equipment and methods.
- C. Submit description of CCTV inspection equipment, sample CCTV inspection logs, and recordings (CD or DVD).
- D. Provide to the Engineer pre- and post-construction video recording and suitable log for each sewer line. All video inspections shall utilize CD or DVD for documentation. Unedited video recordings and a suitable log of the inspection shall be provided to the Engineer five working days prior to rehabilitation and within three working days after rehabilitation.

16-1.03 PREVIOUS INSPECTION VIDEO RECORDINGS

- A. Video recordings of some of the sewers to be rehabilitated are available for viewing. To view existing video, Contractor shall provide an external hard drive or USB drive to the District. Allow 3 working days for videos to be placed on the drive. Contractor shall pick

up the drive from District offices. The Owner makes no express or implied guarantee as to the accuracy or the completeness of the information contained on the video recordings. The Contractor must make their own judgement as to the condition of the sewers and the quantity of cleaning necessary and must not rely on the description provided on the video recordings.

16-1.04 CCTV CAMERA

- A. A pan and tilt color camera shall be used for all video inspection of main lines and shall be one specifically designed and constructed for such inspections. The camera shall be mounted on adjustable skids or a tractor to keep it in the center of the pipe.
- B. The camera shall be 360-degree radial view, color image camera capable of rotating to look directly up tee and wye connections.
- C. Lighting for the camera shall be supplied by a lamp on the camera, capable of being dimmed or brightened remotely from the control panel. The lighting system shall be capable of lighting the entire periphery of the pipe.
- D. The camera shall be operative in 100% humidity conditions and shall have a minimum of 330 lines of resolution.
- E. The camera equipment shall produce a continuously monitored color picture, which will have the resolution capability to discern small hairline cracks and other minor and major defects in the sanitary sewer line. The camera equipment shall be capable of producing digital still pictures for permanent record as required.
- F. The camera shall be self-propelled or pulled by a cable winch from the downstream manhole, through the line along the axis of the pipe, at a uniform rate of 1/2 foot per second maximum.

16-1.05 RECORDINGS

- A. The televising of all lines shall be recorded on CD/DVD disc(s). CD/DVD format video of the televised lines shall become property of the District.
- B. All manhole numbers, line segments, defects, laterals, sags etc. will be noted on video by display and voice, describing said problem or lateral including footage.
- C. Every TV run (MH-MH, MH-cleanout and laterals) shall be recorded as separate files, with the name of the file being the MH and/or cleanout numbers, or the address of the laterals.

16-1.06 CLEANING OF EXISTING SEWER MAINS

- A. Any line cleaning that the Contractor is required to do in order to televise the lines will be included and no additional compensation will be allowed.
- B. All lines shall be flushed clean with a high-pressure commercial sewer flusher unit or by balling prior to televising. If required to televise an existing line it may be necessary to remove roots, grease or other obstructions prior to flushing per these Special Provisions. The equipment shall be appropriate for the type of obstruction being removed and shall not damage the pipe in any way. Cleaning equipment and methods shall be reviewed and approved by the District prior to use. All debris shall be trapped at the first downstream manhole and removed. Debris will be hauled to an appropriate disposal site at the Contractor's expense.
- C. After flushing and prior to televising, an approved source of water will be discharged into the upstream manhole or mainline cleanout until water flows out of the downstream manhole. This is to be done no more than 24 hours before the video inspection takes place. High pressure flushing of the line is not to be considered as a substitute for this

requirement. This shall be done to ensure that all dips or sags are filled before televising, if the sanitary sewer has live flow, the Engineer may waive this requirement. Live flows that are greater than the depth of the gauge shall be temporarily plugged upstream and bypass pumped to allow for proper televising.

- D. The television contractor is responsible for all stuck, broken or lost equipment and shall bear all necessary costs to retrieve or replace said equipment including dig ups.
- E. The Contractor must obtain permission from the Engineer prior to the removal of any manmade or natural obstruction needed to complete this work. Any item removed must be replaced in kind to the satisfaction of the Engineer and will be done at the Contractor's expense.

16-1.07 CCTV INSPECTION PROCEDURES

- A. During this inspection, the Contractor shall be present to observe the televising inspection. Acceptance of any portion of the sanitary sewer work shall not be given in the field at the time of televising.
- B. The following video tape observations shall be considered defects in the construction of the sewer pipelines and will require corrections prior to acceptance:
 - 1. Off grade 0.08 foot, or over, deviation from grade
 - 2. Joint separations over 3/4";
 - 3. Offset joints;
 - 4. Chips in pipe ends none more than 1/4" deep;
 - 5. Cracked or damaged pipe or evidence of the presence of an external object bearing upon the pipe (rocks, root, etc.);
 - 6. Infiltration;
 - 7. Debris or other foreign objects;
 - 8. Other obvious deficiencies when compared to approved Plans and Specifications and these Standards.
- C. If while conducting the initial television inspection for reconstructed sewers, the Contractor discovers areas that need correction, these corrections shall be made and the area televised again prior to submitting the logs to the Engineer for review. If footage of video that is not required for inspection, such as; areas known to need repair, stationary video footage in sanitary sewer lines other than where required and footage not of sanitary sewer facilities, the submittal will be rejected.
- D. The televising contractor is responsible for all stuck, broken, or lost equipment and any damage to sanitary sewer facilities due to their operations and shall bear all necessary costs to retrieve or replace said equipment and make required repairs to sanitary sewer facilities.
- E. Any damage to facilities or obstruction to service caused by the televising operations shall be corrected immediately by the Contractor at no cost to the District.
- F. The Contractor shall obtain permission from the Engineer prior to the removal of any manmade or natural obstruction needed to complete this work. Any item removed shall be replaced in kind to the satisfaction of the Engineer and will be done at the Contractor's expense.
- G. Where infiltration in the sanitary sewer line is suspected, the camera shall be stopped for at least 30 seconds in the area of question and the camera shall pan and/or tilt as

needed to ascertain that infiltration is occurring and the possible cause. The camera shall stop at all lateral connections, defects, sags, etc. for a period of at least 10 seconds and the camera shall pan and/or tilt as needed so that all portions of the connection or defect that is visible from within the main line can be completely inspected.

- H. Each pipe run between manholes being inspected may be required to be isolated from the remainder of the line by the use of a line plug to insure total viewing of the inside periphery of the pipe. The inspection shall be performed in a forward and/or backward direction according to line conditions at the time of the inspection. Every effort shall be made by the Contractor to televise in the same direction as the flow, especially during live flow conditions. The Engineer must approve any video inspection that goes against the flow.
- I. Telephones, sound, power, communication systems, or other suitable means of communication shall be set up between the winch at the downstream manhole and the monitor control and operations van unless camera tractor is used.
- J. The Contractor shall keep a copy of the written logs on site that clearly show the exact location, in relation to the starting manhole/mainline cleanout or lateral cleanout, of each following item discovered during the television inspection; infiltration points, lateral locations, cracks, open/pulled joints, roots, broken or collapsed sections, grease, debris, location of dips (starting and ending footage plus depth), and any other discernible features. In addition to the items noted, the video and written logs shall also note; name of project, general contractor, date, line size, length of section, manhole condition and live flow. Measurement for location of defects shall be at ground level by means of a metering device. Markings on the cable, or the like, which would require interpolation for depth of manhole or lateral cleanout will not be allowed. Measurement meters will be accurate to plus or minus one foot in a thousand and must show on video. A one-inch depth gauge pulled or pushed in front of the camera is required for all main lines up to and including 12-inch. For any line larger the Contractor shall verify required gauge size with the Engineer prior to scheduling television inspection. Measurement of laterals must be recorded on video and written log from bottom of cleanout to main and bottom of cleanout to connection at existing lateral.
- K. The following conditions shall exist prior to the final television inspection:
 - 1. All sanitary sewer lines shall be installed, backfilled and compacted.
 - 2. All structures shall be in place, all channeling complete and all pipelines accessible from structures.
 - 3. All other underground facilities, utility piping and conduit shall be installed and accepted by the Engineer.
 - 4. Mainlines to be inspected shall be balled/high pressure flushed and mandrel tested.
 - 5. Laterals to be inspected shall be flushed.
 - 6. The final air or water test on lines shall have been completed.
- L. Deficiencies revealed by the television inspection, in the opinion of the Engineer, shall be repaired by the Contractor to the satisfaction of the Engineer. After all required repairs are completed the areas of repair shall be televised again at the Contractor's expense.

16-1.08 MEASUREMENT AND PAYMENT

No separate measurement or payment will be made for cleaning and CCTV inspections of sewer mains and laterals. Full compensation for furnishing all labor, materials, tools, equipment and incidentals, and for doing all the work involved will be considered as included

in the lump sum price paid for various other items of work and no additional compensation will be allowed.

SECTION 17 - SEWER FLOW CONTROL

17-1.01 GENERAL

- A. Flow control of existing sewer flows is required for the method of construction specified. It shall be the Contractor's responsibility to maintain at all times the sewer flows throughout the Project site and from the adjacent properties
- B. To the extent possible, Contractor shall schedule work so that all sewer flow control is performed during dry weather periods. Bypass pumping during rain storms will not be allowed.
- C. Coordinate directly with residents to minimize wastewater flows during the scheduled work.
- D. The Contractor may work with residents to minimize discharge to the sewer and may utilize temporary plugging or flow stoppage from the laterals during the work period if no adverse back up of sewage occurs at connected building, otherwise the Contractor shall actively bypass pump from lateral connections and/or cleanouts.

17-1.02 SUBMITTALS

- A. Submit bypass pumping and/or diversion plans for review by the Engineer at least 10 working days prior to the work.
- B. Plan for bypass pumping shall be approved by the Engineer before the Contractor will be allowed to commence bypass pumping.
- C. Notify the Engineer two working days prior to commencing with the bypass pumping operation.
- D. Submit shop drawings that identify the bypass pumping locations and methods with sufficient detail to assure that the work can be accomplished without sewage spill. The bypass pumping plan shall include an emergency response plan to be followed in the event of a failure of the bypass pumping system.

17-1.03 PLUGGING, BLOCKING, AND PUMPING

- A. Provide bypass pumping and/or diversion when required for acceptable completion of the sewer installation. Bypass pumping shall consist of furnishing, installing, and maintaining all power, plugs, primary and standby pumps, appurtenances and bypass piping required to maintain existing flows and services.
- B. Engine generator systems shall be enclosed with a sound attenuated enclosure and shall produce noise emissions less than 60 decibels as measured 60 feet away, if bypass pumping is allowed between the hours of 6 PM and 7 AM.
- C. Bypass pumping shall be done in such a manner as not to damage private or public property or create a nuisance or public menace. The sewage flow control piping shall be completely leak free that is adequately protected from traffic and shall be redirected into the sanitary sewer system. Dumping, leaks or free flow of sewage on private property, gutters, streets, sidewalks, or into storm sewers is prohibited.

17-1.04 MONITORING

- A. Take all necessary precautions including constant monitoring of bypass pumping to ensure that no private residences, businesses or school facilities are subjected to a sewage backup or spill. The Contractor shall be liable for all cleanup, damages, and resultant fines in the event of a spill. After the work is completed, flow shall be restored to normal.

17-1.05 MEASUREMENT AND PAYMENT

Sewer Flow Control will be paid for at the contract Lump Sum price, which price shall include full compensation for furnishing all labor, materials, tools, and equipment, including emergency response plan and doing all work involved in providing a sewer flow control system, and no additional compensation will be allowed.

SECTION 18 - SANITARY SEWER CONSTRUCTION

18-1.01 GENERAL

- A. Sanitary sewer main and related appurtenances shall be constructed as shown on the Plans in accordance with these Special Provisions.
- B. The Contractors attention is directed to the Section entitled "Water Pollution Control" and "Sheeting, Shoring and Bracing" of these Special Provisions.
- C. The Contractor shall utilize the necessary installation procedures that will insure the pipes are installed at the location and to the grade staked in the field. The Contractor shall furnish all equipment necessary to install and inspect pipe installation.
- D. All trench bedding and backfill material for sanitary sewer mainline and service laterals shall be in accordance with the details shown in the Plans and these Technical Specifications.
- E. The Contractor shall provide a television inspection and pressure testing of the new sewer main(s) prior to acceptance of the project. Testing shall be in accordance with the District Standards and these Special Provisions
- F. Asphalt concrete shall conform to the requirements of the section titled "Asphalt Concrete Trench Paving" elsewhere in these Special Provisions. All trenches shall be paved in accordance with the trench details shown on the Plans.
- G. Proper implements, tools and facilities satisfactory to the District shall be provided and used by the Contractor for safe, convenient and workmanlike prosecution of the work.

18-1.02 SUBMITTALS

- A. Submit work plan and details of all pipe, joints, fittings, marking tape, and appurtenances to be used in the work.
- B. Submit detailed layouts and schematics describing the installation of all piping. The Contractor shall include site maps indicating all locations where butt-fusion welding work will occur, lay-down areas, pipe storage areas, insertion pits, and pulling pits.
- C. Winch system: Product information such as catalog sheets, specifications, dimensioned drawings, pulling capacity (in tons), installation details/sketches and other pertinent information for the proposed installation work.
- D. Fusion machine: Product information such as catalog sheets, specifications, welding procedures, data logger and a sample of the recorded welding sequence.
- E. Mole: Type of bursting head used for the project.

18-1.03 SANITARY SEWER MAIN REPLACEMENT BY PIPE BURSTING:

- A. Pipe shall be installed in accordance with IPBA/NASSCO Guideline Specification for the Replacement of Mainline Sewer Pipes by Pipe Bursting and ASTM F585.
- B. The pipe bursting unit shall be designed and manufactured to force its way through the existing line by fracturing the pipe and compressing the broken pieces into the surrounding soil as the equipment progresses. The bursting unit shall generate sufficient force to burst and compact the existing pipeline. The bursting unit shall pull the polyethylene pipe with it as it moves forward. If pipe obstructions or pipe materials prevent the existing pipe from being burst properly and cannot be removed by conventional cleaning equipment, the Contractor shall make a point repair as approved by the Engineer. Excavation of the insertion pits shall be at locations determined by the Contractor. The Contractor shall utilize existing manholes where practical. Insertion pits

shall be of sufficient length to allow the bursting head and pipe to enter the host pipe at an angle that will maintain the grade of the existing sewer.

- C. Manhole inverts and bottoms shall be removed to permit access for installation equipment. Structural damage to manholes during pulling operations shall be repaired at no extra cost.
- D. Fused joints shall be watertight and shall have tensile strength equal to that of the pipe. The inside weld bead shall be removed by cutting the bead away without scoring the inside wall of the pipe. The Contractor shall submit to the Engineer, for review as part of the submittal requirements, a de-beading process for use in removing the internal bead for the newly joined pipe sections.
- E. Manhole inverts and bottoms shall be removed as required to permit access for installation equipment. Pipe to manhole connections shall be made with ISCO HDPE thermal-fused pipe restraints or approved equal, installed on the top of the pipe inside the manhole. The pipe shall be allowed to relax for a minimum of 12 hours (or longer period of time as determined by the Contractor based upon soils conditions and pulling force) prior to installation of the restraint and trimming any excess from the end of the pipe.

18-1.04 SPOT REPAIRS OF EXISTING SANITARY SEWER MAINS

- A. Contractor shall CCTV inspect existing sewer mains to verify if there are locations that require spot repairs prior to pipe bursting.
- B. Spot repairs include open-cut replacement up to 10 linear feet of sewer main to remove defects such as severe offset joints, collapsed or broken pipe, sags, etc.

18-1.05 SANITARY SEWER LATERALS

- A. All active sanitary sewer laterals shall be reconnected to the main where shown on the Plans and in accordance with these Special Provisions, and as directed by the Engineer.
- B. The estimated locations of the existing laterals are shown on the Plans based on record information, television inspection, and field evidence. This information is available for review upon request. The Contractor shall have the sole responsibility for determining the exact location of all existing laterals. Contractor shall determine which laterals are active and inactive prior to construction. Only active sewer laterals are to remain in service at all times and shall be connected to the new sewer main as the main is being constructed.
- C. Lateral to HDPE pipe main connections shall be made with thermal-fused fittings. Couplings for connection of dissimilar materials shall be Mission Flex-Seal Adjustable Repair Couplings or Fernco Strong Back RC Couplings.
- D. The Contractor's attention is directed to Section 10-1.14 "Owner Notification" of these Special Provisions. Suitable means for redirecting flows from active sewer laterals shall be employed while constructing new sewer mains. Temporary sewer lateral connections shall be replaced with permanent laterals after installation of the sewer mainline is completed.
- E. Existing irrigation facilities may be encountered. The Contractor shall coordinate with the property owner and repair any damage to existing landscaping and irrigation facilities caused by his operations at the Contractor's expense.

18-1.06 MEASUREMENT AND PAYMENT

A. Replace Sewer Main with HDPE by Pipe Bursting shall include payment for all work, equipment, materials, and incidentals necessary to replace size for size the existing sanitary sewer using pipe bursting method.

1. Measurement for payment shall be per 3-D "Linear Foot" length from the center of the upstream and downstream cleanouts or manholes shown on the drawings and shall be full compensation for:
 - a) locating, exposing and measuring cleanout or manholes not previously surveyed,
 - b) pre and post CCTV inspections,
 - c) submittals; locating/potholing and protecting existing utilities; surveying;
 - d) saw cutting, grinding, surface demolition; excavation, removal and proper disposal of concrete, asphalt, and asphalt containing reinforcing fabric,
 - e) excavation, dewatering, spoil handling and proper disposal for all insertion and receiving pits
 - f) protection of all existing utilities and service laterals within trench,
 - g) disconnection of existing laterals,
 - h) equipping of insertion and receiving facilities, furnishing, installing, and operating all pneumatic or static-pull pipe bursting equipment, or specialized equipment required for bursting pipe,
 - i) removal and disposal of existing sewer pipe and fittings where necessary,
 - j) removal of manhole inverts as required for new pipe installation, including reconstructing flow channels,
 - k) furnishing and installing pipe and fittings,
 - l) connection to mains and manholes, pipe restraints,
 - m) repairing all defects (sags) after bursting, and installing CDF saddles,
 - n) furnishing, preparing and compacting pipe sub base, bedding and backfill at insertion and receiving pit locations,
 - o) furnishing, placing and compacting asphalt concrete,
 - p) restoring all surfaces including sidewalks, concrete paving, curbs, gutters, median, pavement striping and marking,
 - q) restoring landscape and ground cover, repairing irrigation system; resetting valve boxes, monuments, and other surface features disturbed by the work,
 - r) repair of pavement and surface improvements damaged by surface heave,
 - s) furnishing personnel, and materials necessary for the installation,
 - t) record drawings, and all incidentals required by these Specifications and Drawings.
2. In the event of an increase or a decrease in the amount of the Engineer's Estimated quantity for "Replace Sanitary Sewer Main with HDPE by Pipe Bursting," such increase or decrease shall not be considered an alteration in

excess of the 25 percent of the contract amount of such items under provisions of Section 4-1.05A of the Standard Specifications and no adjustment of the contract price will be made by reason of such increase or decrease.

B. **Spot Repair Sewer Main** shall include payment for all work, equipment, materials necessary to repair defects including grade breaks, offset joints, and collapsed, broken or missing pipe.

1. Measurement and payment will be for "Each" spot repair and shall be full compensation for:

- a) Submittals, locating/potholing and protecting existing utilities, surveying,
- b) pre and post CCTV inspection,
- c) cleaning of sewer mains,
- d) verifying limits of spot repair,
- e) saw cutting, grinding, surface demolition, excavation, removal and proper disposal of concrete, asphalt, and asphalt containing reinforcing fabric,
- f) trenching, dewatering, spoil handling and proper disposal
- g) protection of all existing utilities and service laterals within trench,
- h) removal and disposal of existing sewer pipe and fittings, furnishing and installing pipe and fittings, connection to existing main or manhole,
- i) furnishing and preparing and compacting pipe sub base, furnishing, placing and compacting pipe bedding, furnishing, placing and compacting trench backfill,
- j) furnishing, placing and compacting asphalt concrete,
- k) restoring all surfaces including sidewalks, concrete paving, curbs, gutters, median, pavement striping and markings,
- l) restoring landscape and ground cover, repairing irrigation system, resetting valve boxes, monuments, replacing traffic signal loops, and other surface features disturbed by the work,
- m) dust control, testing, cleaning; record drawings,
- n) and all incidentals required by these Special Provisions and Drawings.
- o) Each spot repair may require removal and replacement of up to 10 feet of pipe and fittings.

2. In the event of an increase or a decrease in the amount of the Engineer's Estimated quantity for "Spot Repair Sanitary Sewer Main," such increase or decrease shall not be considered an alteration in excess of the 25 percent of the contract amount of such items under provisions of Section 4-1.05A of the Standard Specifications and no adjustment of the contract price will be made by reason of such increase or decrease.

C. **Reconnect Sewer Lateral on Private Property** shall include payment for all work, equipment, materials, and incidental necessary to reconnect existing lateral to new rehabilitated sewer main.

1. Measurement shall be per "Each" existing sewer lateral reconnected and shall include full compensation for:

- a) all efforts required to locate laterals,
- b) removal of asphalt concrete and Portland cement concrete,
- c) installing and removing temporary laterals,
- d) tying-in to the existing laterals and installing flexible couplings,
- e) re-connection to the sewer main,
- f) saw cutting, grinding, surface demolition; excavation, removal and proper disposal of concrete, asphalt, and asphalt containing reinforcing fabric,
- g) trenching, dewatering, spoil handling and proper disposal
- h) protection of all existing utilities and service laterals within trench,
- i) preparing and compacting pipe sub base,
- j) furnishing, placing and compacting pipe bedding,
- k) furnishing, placing and compacting trench backfill,
- l) furnishing and installing two-way cleanout and plug, cleanout box, frame and cover for sewer lateral on same side as sewer main,
- m) protection of the pipe from damage during other phases of the work,
- n) bypass pumping (if needed),
- o) furnishing, placing and compacting asphalt concrete,
- p) furnishing materials for restoring all surfaces including sidewalks, concrete paving, curbs, gutters, median, pavement striping and markings,
- q) restoration/reconstruction of landscaping/irrigation,
- r) and any other items necessary to place the laterals not specifically enumerated in the Plans or these Specifications, and no additional compensation will be allowed.

SECTION 19 - SANITARY SEWER STRUCTURES

19-1.01 MAIN LINE CLEANOUT REPLACEMENT

- A. Where shown on the Plans, remove and replace or install new, all main line cleanouts after sewer main rehabilitation.
- B. Cleanout size shall be equal to the size of sewer main as indicated on the Plans.
- C. Tops of cleanout frames and covers shall be set accurately to finished grade in paved areas and one-inch above surrounding grade in lawn or landscaped areas. The frame shall be evenly set on the cleanout in a Portland cement concrete collar.

19-1.02 MEASUREMENT AND PAYMENT

Replace Main Line Cleanout shall include payment for all work, equipment, materials, and incidentals necessary to remove and replace end of line cleanouts by open cut construction.

- 1. Measurement for payment shall be per "Each" end of line cleanout installed at the locations shown on the drawings and shall be full compensation for:
 - a) Submittals, locating/potholing and protecting existing utilities, surveying;
 - b) Locating buried cleanout or end of pipe;
 - c) saw cutting, grinding, surface demolition, excavation;
 - d) removal and proper disposal of concrete, asphalt, and asphalt containing reinforcing fabric;
 - e) trenching, dewatering, spoil handling and proper disposal;
 - f) protection of all existing utilities and service laterals within trench;
 - g) removal and proper disposal of existing cleanouts, existing brick manholes, and plastic manholes;
 - h) furnishing and installing sewer pipe, fittings, and couplings, concrete collar, box, frame and cover, connecting mainlines to new cleanout;
 - i) other work necessary to installing end of line cleanouts not specifically enumerated in the Drawings or Special Provisions, and no additional compensation will be allowed.

SECTION 20 - TESTING OF SEWER SYSTEMS

20-1.01 GENERAL

- A. Testing of all portions of the sewer will be required.

20-1.02 LEAKAGE TESTING OF PIPING

- A. For either exfiltration or infiltration test, the maximum leakage shall not exceed 50 gallons per inch of pipe diameter per mile per 24 hours as measured over a period of 30 minutes minimum. Should the leakage exceed the maximum allowable rate, the Contractor shall repair, overhaul, or rebuild the defective portion of the sewer line to the satisfaction of the District at no additional cost to the District. After repairs have been completed by the Contractor, the line shall be retested as specified above, all at no cost to the District.

- B. The test shall be performed after the line has been laid and all backfill placed and compacted as specified elsewhere in these specifications. The Contractor, at his option, may test the line at any time during construction. However, the final test for acceptance shall be made only after all backfill is in place and compacted.
- C. In the event that the exfiltration test prescribed above is impractical due to wet trench conditions, these portions of the sewer line where such conditions are encountered will be tested for infiltration. The Engineer shall determine whether the exfiltration or infiltration test will be used. Even though the test for leakage is within the prescribed limits, the Contractor shall repair any obvious leaks.

20-1.03 AIR TESTING OF PIPING

- A. Low pressure air testing may be used in lieu of water testing at the option of the Contractor. The following procedure shall be used for air testing.
 - 1. Clean pipe to be tested by propelling a snug fitting inflated rubber ball through the pipe with water. Remove any debris.
 - 2. Plug all pipe outlets with suitable test plugs. Brace each plug securely.
 - 3. If the pipe to be tested is submerged in ground water, Inspector may require that gauge pressures be increased to compensate for groundwater hydrostatic pressure.
 - 4. Add air slowly to the portion of the pipe installation under test until the internal pressure is raised to 4.0 psig.
 - 5. Check exposed pipe and plugs for abnormal leakage by coating with a soap solution. If any leakage is observed, bleed off air and make necessary repairs.
 - 6. After an internal pressure of 4.0 psig is obtained, allow at least two minutes for air temperature to stabilize, adding only the amount of air required to maintain pressure.
 - 7. After the two-minute period, disconnect the air supply.
 - 8. When pressure decreases to 3.5 psig start stopwatch. Determine the time in seconds that is required for the internal air pressure to reach 3.0 psig. The minimum allowable time in seconds shall be based on the diameters and lengths of pipe under test. The Contractor will be allowed to manually bleed air as required to drop the internal pressure to 3.5 psig to start test.
 - 9. The minimum test time (minutes:seconds) considered acceptable is indicated on the Air Test Table:

Minimum Test Time for 1 PSI Pressure Drop		
Pipe Diameter, inches	Test Time, seconds/ft x feet	Minimum Test Time, minutes:second
4	0.380	3:46
6	0.854	5:40
8	1.520	7:33
10	2.374	9:26
12	3.418	11:20
15	5.342	14:10

20-1.04 MEASUREMENT AND PAYMENT

No separate measurement or payment will be made for testing of sanitary sewer systems. Full compensation for furnishing all labor, materials, tools, equipment and incidentals, and for doing all the work involved will be considered as included in the lump sum price paid for various other items of work and no additional compensation will be allowed.

PROJECT PLANS

ORIGINAL PLOT DATE: DRG DATE

FOR REDUCED PLANS, THE ORIGINAL SCALE IS IN INCHES

3
2
1
0

Images: I:\AA - Sta. Proj. - Xeric: Caliform B-meadow\B-meadow\CSE-ENGINEERS-STAMPS-COVER-ENGINEERS-STAMPS-PLAN.dwg
Path: F:\chil_3d_projects\994413\map\1 - 00\dwg Layout Name: SH. 1 Plot Date: Aug 06, 2020 at 16:24

PROJECT PLANS FOR :

MEADOW VIEW EASEMENT SEWER REHABILITATION

AUGUST 2020

HIDDEN VALLEY LAKE COMMUNITY SERVICES DISTRICT LAKE COUNTY, CALIFORNIA

FOR USE IN CONJUNCTION WITH :

CALTRANS STANDARD SPECIFICATIONS DATED 2018
CALTRANS STANDARD PLANS DATED 2018

GENERAL NOTES

- EXCAVATIONS OVER FIVE FEET (5') DEEP REQUIRE AN EXCAVATION PERMIT FROM THE STATE DEPARTMENT OF INDUSTRIAL SAFETY.
- CONTRACTOR SHALL CALL "USA NORTH" AT (800) 642-2444 AT LEAST TWO (2) WORKING DAYS PRIOR TO START OF CONSTRUCTION FOR LOCATING UNDERGROUND UTILITIES.
- CONSTRUCTION CONTRACTOR AGREES THAT IN ACCORDANCE WITH GENERALLY ACCEPTED CONSTRUCTION PRACTICES, CONSTRUCTION CONTRACTOR WILL BE REQUIRED TO ASSUME SOLE AND COMPLETE RESPONSIBILITY FOR JOB SITE CONDITIONS DURING THE COURSE OF CONSTRUCTION OF THE PROJECT, INCLUDING SAFETY OF ALL PERSONS AND PROPERTY; THAT THIS REQUIREMENT SHALL BE MADE TO APPLY CONTINUOUSLY AND NOT BE LIMITED TO NORMAL WORKING HOURS, AND CONSTRUCTION CONTRACTOR FURTHER AGREES TO DEFEND, INDEMNIFY AND HOLD DESIGN PROFESSIONAL HARMLESS FROM ANY AND ALL LIABILITY, REAL OR ALLEGED, IN CONNECTION WITH THE PERFORMANCE OF WORK ON THIS PROJECT, EXCEPTING LIABILITY ARISING FROM THE SOLE NEGLIGENCE OF THE DESIGN PROFESSIONAL.
- UNAUTHORIZED CHANGES & USES: THE ENGINEER PREPARING THESE PLANS WILL NOT BE RESPONSIBLE FOR, OR LIABLE FOR, UNAUTHORIZED CHANGES TO OR USES OF THESE PLANS. ALL CHANGES TO THE PLANS MUST BE IN WRITING AND MUST BE APPROVED BY THE PREPARER OF THESE PLANS.
- NOTICE TO CONTRACTORS: THE EXISTENCE AND LOCATION OF ANY UNDERGROUND UTILITY LINES OR STRUCTURES SHOWN ON THESE PLANS WERE OBTAINED BY A SEARCH OF AVAILABLE RECORDS. THE CONTRACTOR IS REQUIRED TO TAKE DUE PRECAUTIONARY MEASURES TO PROTECT THE UTILITY LINES SHOWN AND ANY OTHER LINES NOT OF RECORD OR NOT SHOWN ON THESE PLANS. OVERHEAD UTILITIES MAY NOT BE SHOWN ON THE PLANS. AS A PART OF THEIR PRE-BID INSPECTION, BIDDERS SHALL NOTE THE TYPE AND LOCATION OF OVERHEAD UTILITIES IN THE WORK AREA AND SHALL INCLUDE PROVISIONS FOR WORKING IN THOSE AREAS. NO ADDITIONAL COMPENSATION WILL BE ALLOWED.
- THE CONTRACTOR SHALL BE RESPONSIBLE FOR ANY DAMAGES TO HOA OR PRIVATE PROPERTY OR OTHER UTILITIES CAUSED BY HIS OPERATIONS. ALL IRRIGATION LINES AND COMPONENTS DISTURBED BY CONSTRUCTION SHALL BE REPAIRED AND RESTORED TO WORKING CONDITION. ANY DAMAGED LAWN OR LANDSCAPING OR PRIVATE PROPERTY IMPROVEMENTS SHALL BE REPLACED.
- THE CONTRACTOR SHALL MAINTAIN REASONABLE ACCESS TO THE SITE AND ALL DRIVEWAYS DURING CONSTRUCTION. MAIL SERVICE SHALL BE MAINTAINED THROUGHOUT THE COURSE OF THIS PROJECT. THE U.S. POSTAL SERVICE SHALL HAVE UNINTERRUPTED ACCESS TO MAILBOXES AT ALL TIMES.
- THE CONTRACTOR SHALL BE RESPONSIBLE FOR OFF-SITE DISPOSAL OF ALL PAVEMENT, CONCRETE AND REINFORCEMENT, SEWER MATERIALS AND SPOILS NOT NEEDED FOR BACKFILL AS REQUIRED BY THE ENGINEER AND PER THE SPECIFICATIONS.
- THE CONTRACTOR SHALL POSSESS A VALID CLASS "A" LICENSE AT THE TIME THE CONTRACT IS AWARDED.
- ANY DAMAGE RESULTING FROM SEWAGE OVERFLOW AND SPILLAGE SHALL BE BORNE BY THE CONTRACTOR. CONTRACTOR IS CAUTIONED THAT THE SANITARY SEWER, MANHOLES, AND OTHER APPURTENANCES ARE PART OF AN OPERATING WASTE WATER FACILITY. THESE FACILITIES RUN CONTINUOUSLY AND MUST MEET STATE AND FEDERAL PERMIT REQUIREMENTS. IF AN OVERFLOW, SPILL, DISCHARGE, OR LEAK OCCURS BECAUSE OF THE CONTRACTOR'S OPERATION OR NEGLIGENCE, THE CONTRACTOR SHALL BE SOLELY LIABLE FOR THE DAMAGES (INCLUDING FINES).
- ALL EXCAVATIONS OR TRENCHES IN PAVED AREAS SHALL REQUIRE SAW CUTTING IN A NEAT AND UNIFORM MANNER. TRENCH BACKFILL SHALL COMPLY WITH EASTERN MUNICIPAL WATER DISTRICT STD. DETAILS SB-157 AND SB-158 (EMWD.ORG/SEWER-STANDARDS-DRAWINGS)
- ALL STREETS, ALLEYS, VEHICULAR WAYS, SIDEWALKS, AND HAUL ROUTES SHALL BE KEPT CLEAN AND CLEAR OF DEBRIS, DIRT, AND DUST IN A MANNER ACCEPTABLE TO THE CITY. AT A MINIMUM, THESE AREAS SHALL BE CLEANED AT THE END OF EACH WORK DAY. FAILURE TO DO SO WILL RESULT IN A STOP WORK NOTICE. SAID NOTICE WILL NOT BE RELEASED UNTIL THE AREA HAS BEEN ADEQUATELY CLEANED. NO ADDITIONAL COMPENSATION WILL BE ALLOWED FOR THIS WORK.
- CONTRACTOR SHALL REPLACE ALL STRIPING AND PAVEMENT MARKING DISTURBED BY CONSTRUCTION TO PRE-CONSTRUCTION CONFIGURATION.
- LATERALS (HOUSE CONNECTION SEWERS) ARE SHOWN ON THE DRAWINGS IN THEIR APPROXIMATE LOCATION. THE LATERALS ARE NOT DRAWN TO SCALE AND THE SYMBOL REPRESENTING THE LATERALS IS INTENDED TO SHOW THE APPROXIMATE LOCATION OF THE LATERALS. ALL LATERALS MAY NOT BE SHOWN. THE CONTRACTOR SHALL LOCATE ACTIVE LATERALS THAT CONNECT TO THE REHABILITATED SEWER LINES AND RECONNECT THEM AS DESCRIBED ON THE DRAWINGS.
- THE CONTRACTOR SHALL POTHOLE CROSSING AND CONNECTING UTILITIES AS NEEDED FOR PIPE BURSTING TRENCHLESS WORK BEFORE STARTING CONSTRUCTION AND PROVIDE ELEVATIONS OF THE TOP OF PIPE, SIZE OF PIPE, AND INVERT OF PIPE TO THE ENGINEER. IT IS THE CONTRACTOR'S RESPONSIBILITY TO DETERMINE WHICH UTILITY CROSSING SHOULD BE POTHOLE BASED ON THE CRITERIA PROVIDED HEREIN. ANY UTILITY CROSSING DAMAGED AS A RESULT OF PIPE BURSTING SHALL BE REPAIRED AT THE CONTRACTOR'S COST.
- MANHOLE DEPTHS ARE APPROXIMATE. SEWER MAIN DEPTHS MAY DIFFER FROM THE DEPTH SHOWN ON THE PLANS.

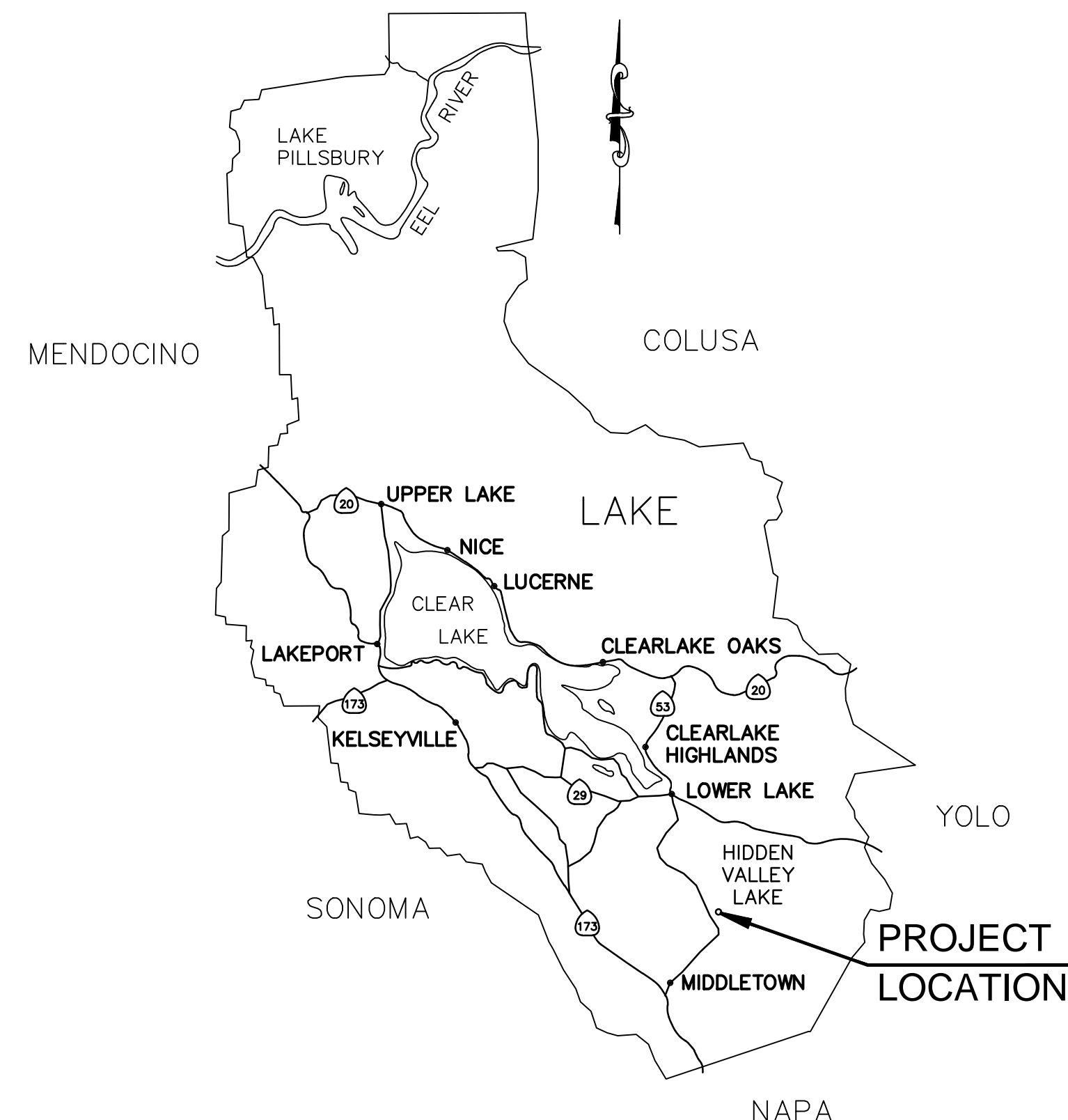

VICINITY MAP
NOT TO SCALE

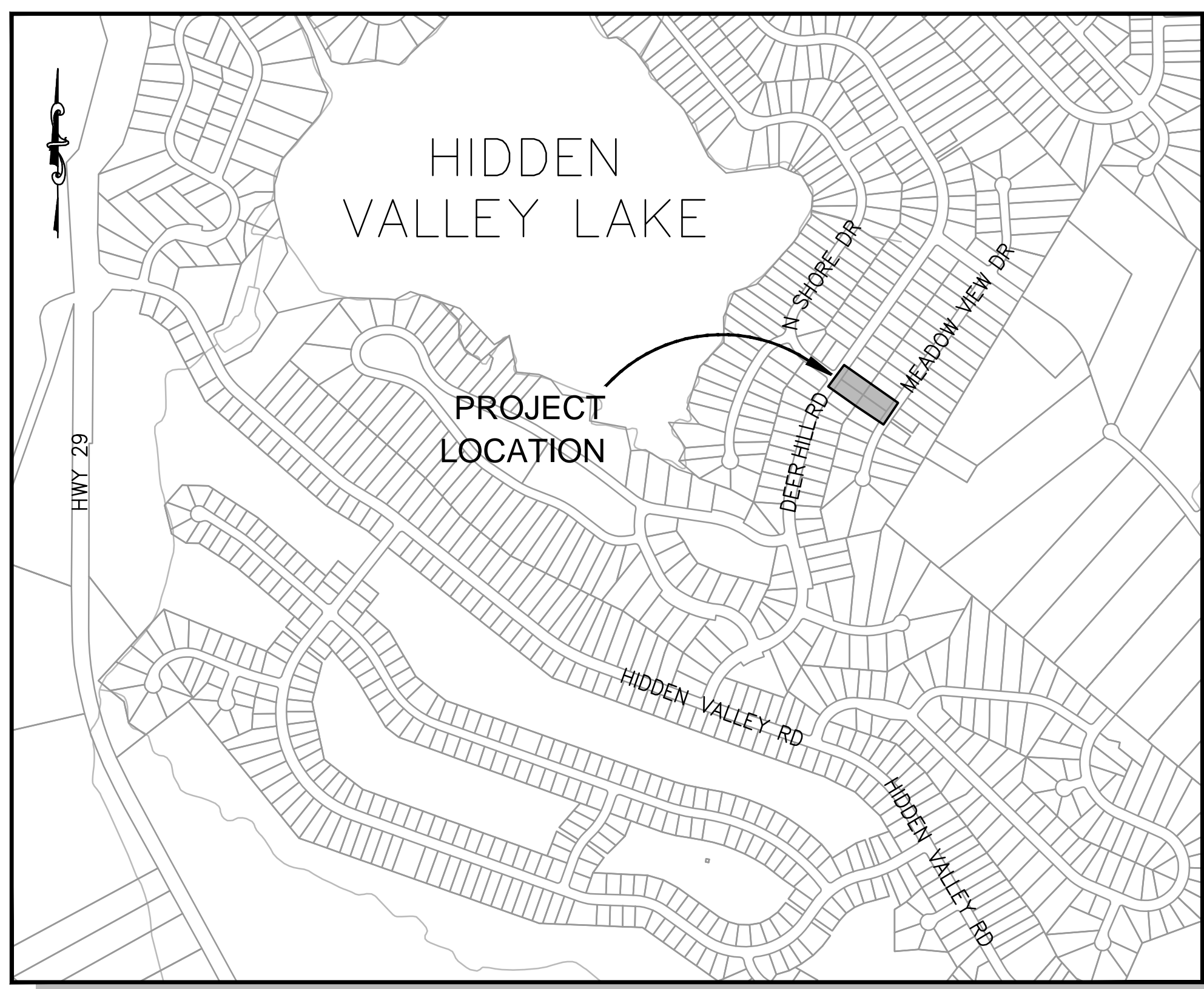

LOCATION MAP
NOT TO SCALE

SHEET INDEX

Sheet Number	Sheet Title
1	COVER SHEET
2	SITE PLAN & DETAILS

UTILITY CONTACTS

HIDDEN VALLEY LAKE CSD
(707) 987-9201

AT&T
(415) 433-4900

PG & E
(877) 743-7782

MEDIACOM
(845) 490-3326



Coastland Civil Engineering, Inc.
1400 Neotomas Avenue, Santa Rosa, CA 95405
707.571.8005 707.571.8037 Fax

Jennifer A. Melman 08/07/2020
JENNIFER A. MELMAN, RCE C62260 DATE



PROJECT NUMBER 99-4413
DRAWING DATE AUGUST 2020
DRAWING NUMBER 1 OF 2

ORIGINAL PLOT DATE:

FOR REDUCED PLANS, THE ORIGINAL SCALE IS IN INCHES

Images: JAM, SJP, JAC, YAC, Callaghan; B-maps; dms; CCE-ENGINEERS; STAMPS-COVERS; CCE-ENGINEERS; STAMPS-DR; M4.dwg; Paths: F:\coll\3d_projects\994413\994413.dwg; Layout: Name: SP & DET SH.2; Plot Date: Aug 06, 2020 at 16:32



CONSTRUCTION NOTES

- (S1) REPLACE EXISTING 6" ACP SANITARY SEWER WITH 6" HDPE BY PIPE BURSTING FROM MANHOLE TO MANHOLE.
- (S2) REPLACE OR RECONNECT MAIN LINE CLEANOUT PER DETAIL (3)
- (S3) RECONNECT ACTIVE LATERALS TO REPLACED SEWER MAIN WITH THERMAL-FUSED TEE FITTINGS PER SPECIFICATIONS.
- (S4) SPOT REPAIR LARGE OFFSET JOINTS.
- (S5) SPOT REPAIR SEVERE OFFSET JOINT PRIOR TO PIPE-BURSTING.
- (S6) LATERAL CONNECTION LOCATION IS UNKNOWN. CONTRACTOR TO LOCATE AND RECONNECT LATERAL TO REPLACED SEWER MAIN.
- (S7) CONNECT HDPE PIPE TO EXISTING MANHOLE AND RESTORE MANHOLE PER DETAIL (1)

SEWER NOTES

1. STATIONING IS MEASURED IN FEET FROM MH1 AS OBSERVED IN THE CCTV VIDEO
2. LOCATIONS SHOWN FOR MANHOLES, SEWERS, LATERALS, CLEANOUTS, PARCEL LINES AND EASEMENTS ARE APPROXIMATE. CONTRACTOR TO FIELD VERIFY LOCATIONS

ABBREVIATIONS:

APPROX	APPROXIMATE
CO	CLEANOUT
EMWD	EASTERN MUNICIPAL WATER DISTRICT
JP	JOINT POLE
LF	LINEAR FEET
MH	MANHOLE
OHE	OVERHEAD ELECTRIC
SS	SANITARY SEWER
STA	STATION
W	WATER SERVICE

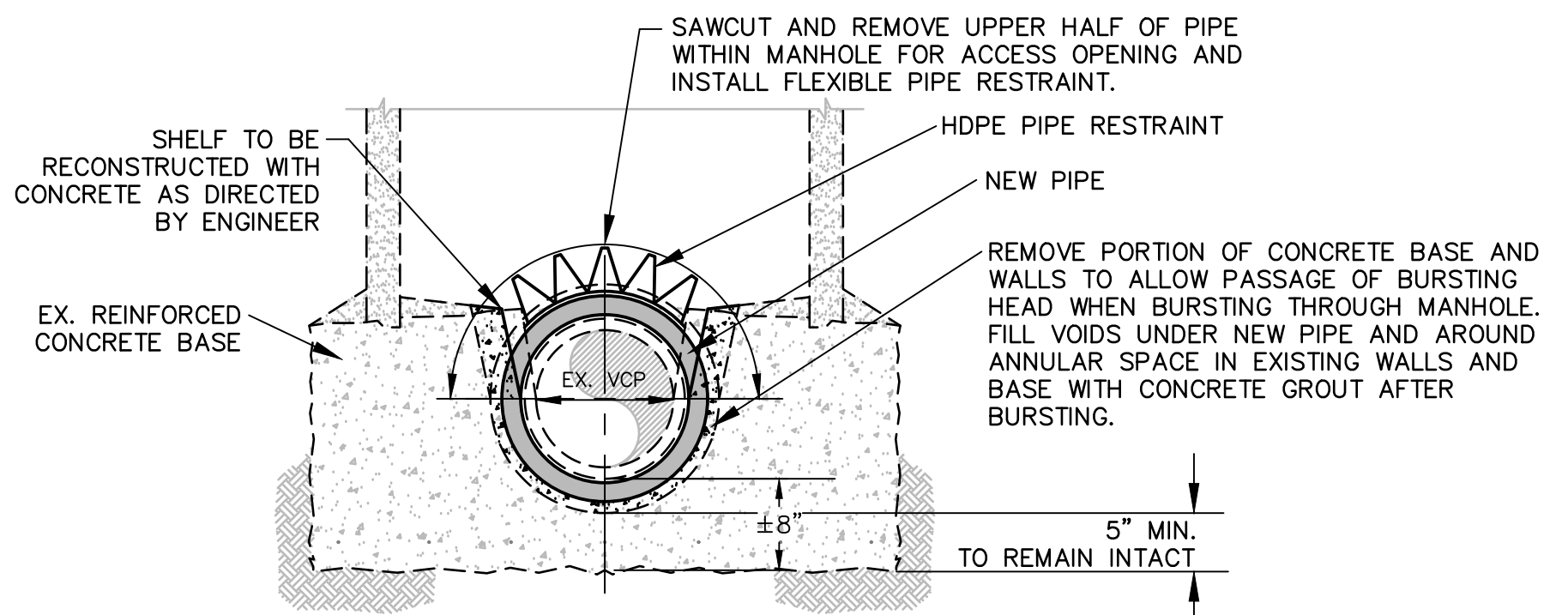

1 PIPE BURSTING CONNECTION TO EX. MANHOLE
NOT TO SCALE

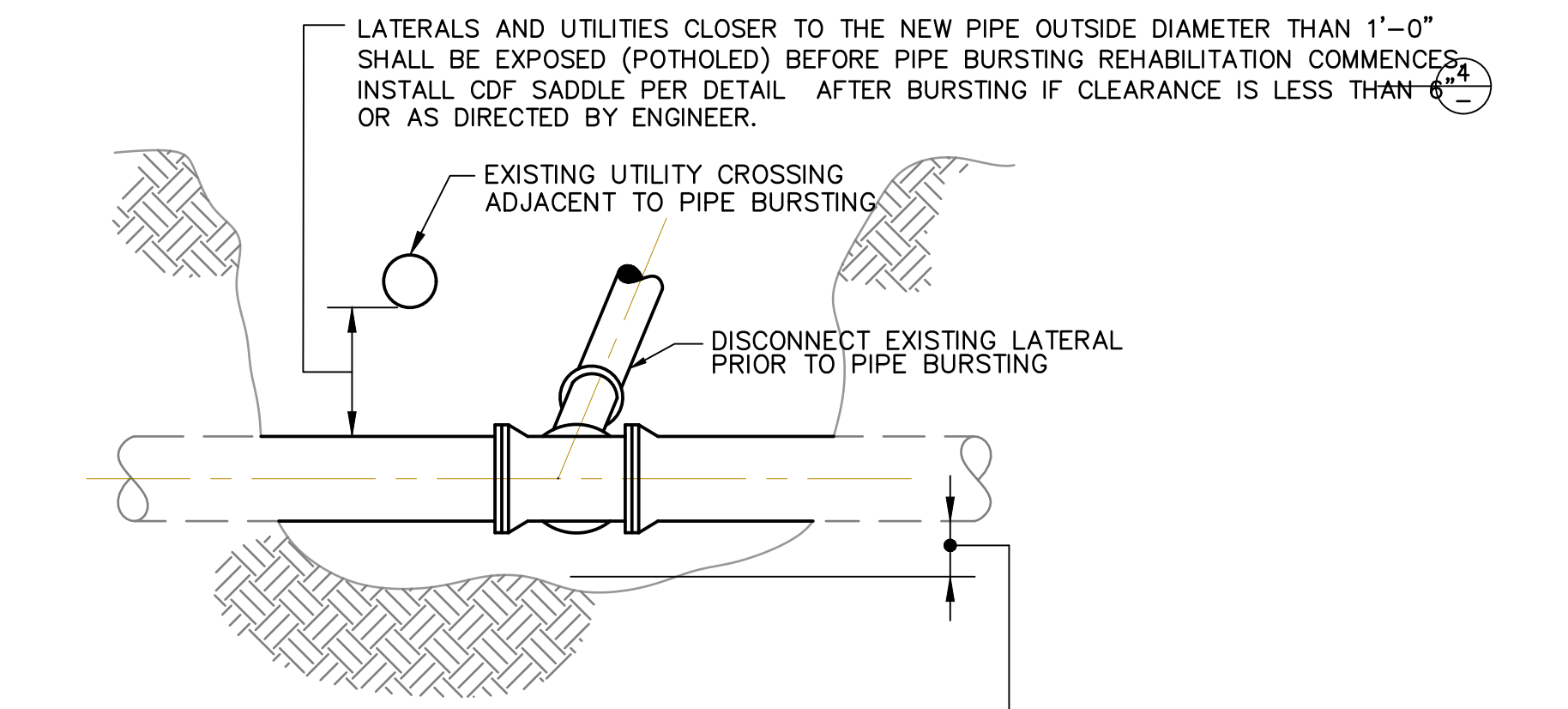

2 PIPE BURSTING REQUIRED CLEARANCES
NOT TO SCALE

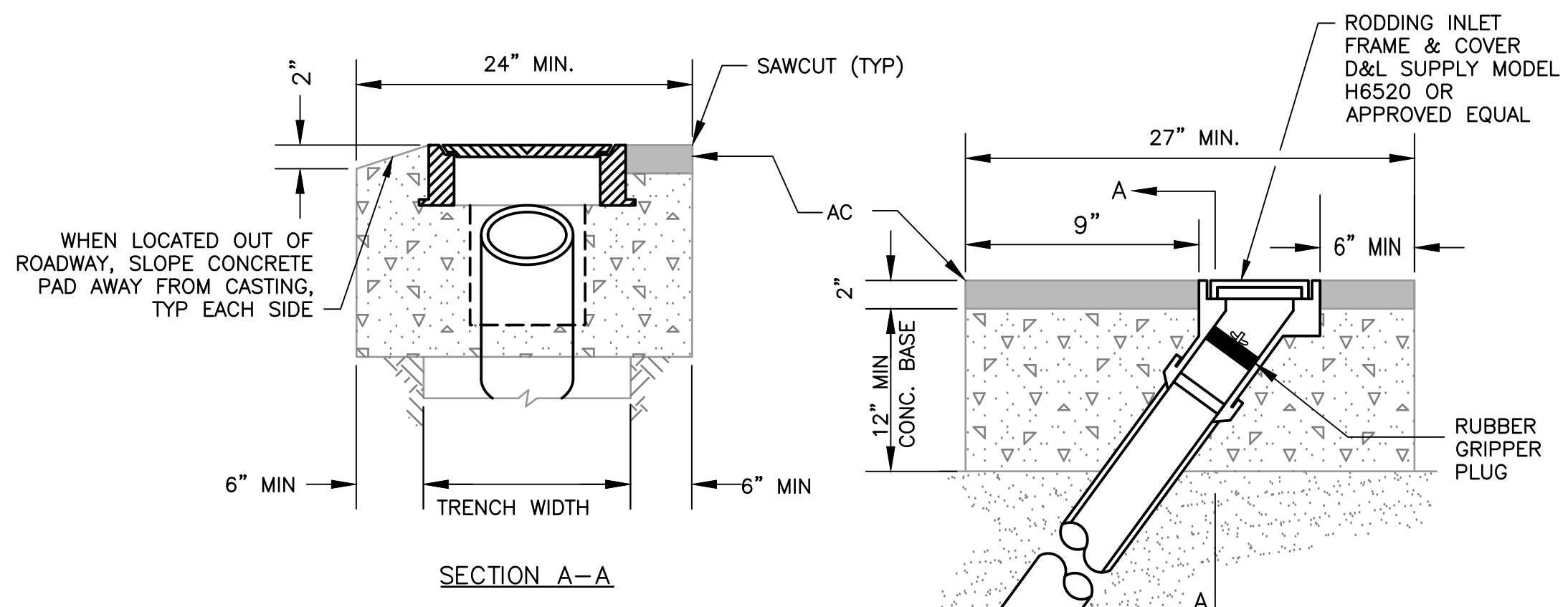

3 MAINLINE CLEANOUT
NOT TO SCALE

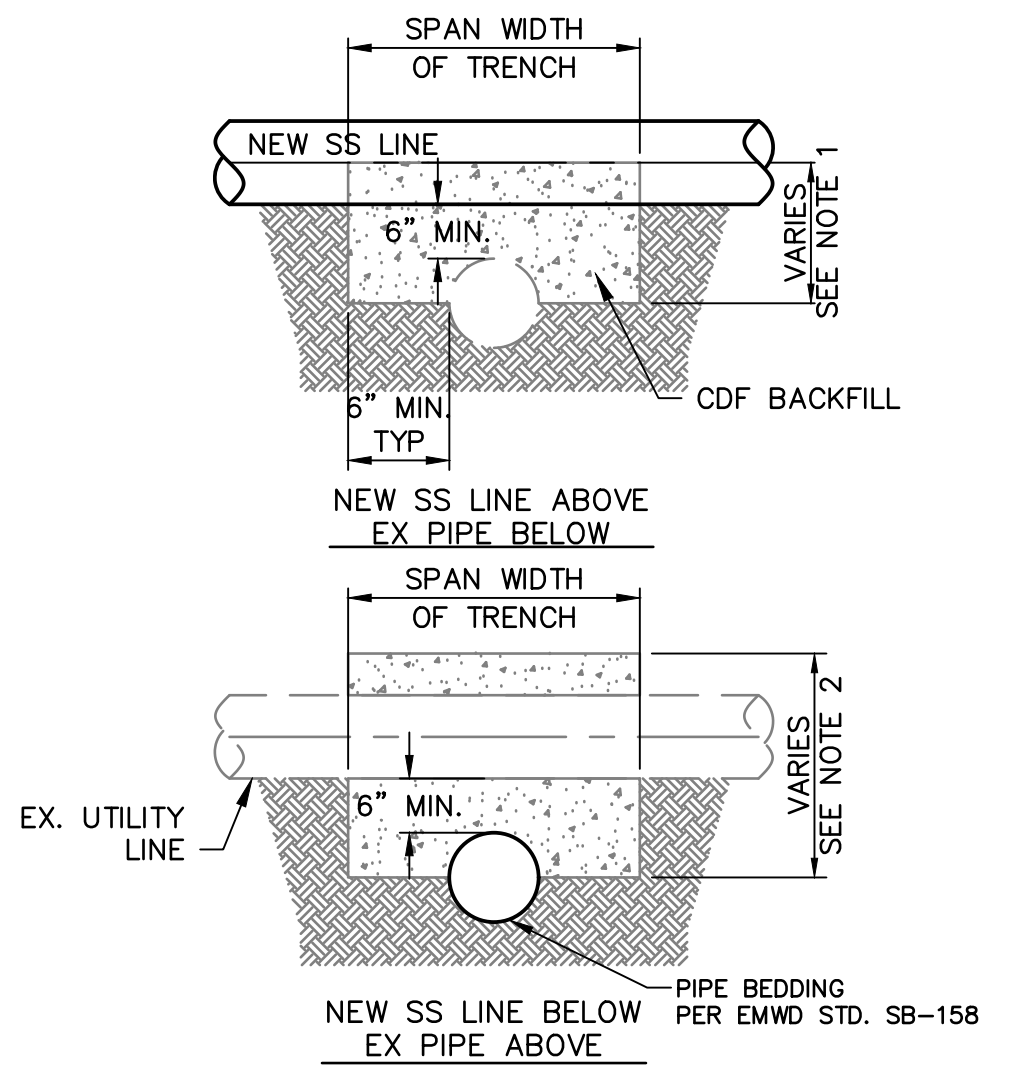

4 CDF SADDLE
NOT TO SCALE

- NOTES:**
1. INSTALL CDF BACKFILL SPRINGLINE TO SPRINGLINE.
 2. INSTALL CDF BACKFILL FROM NEW SANITARY SEWER SPRINGLINE TO 6-INCHES ABOVE THE TOP OF THE EXISTING PIPE.
 3. PROVIDE PROPER SUPPORT OF EXISTING PIPE ABOVE NEW SANITARY SEWER MAIN.
 4. INSTALL 1/2" STYROFOAM WHERE CONCRETE COMES IN CONTACT WITH PIPE.

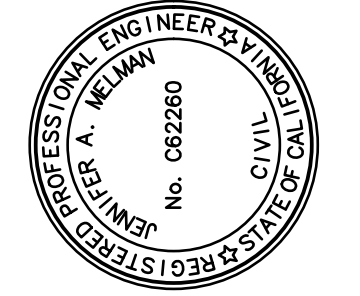

PREPARED UNDER THE DIRECTION OF
 JENNIFER A. WELMAN 08/07/19 DATE
 JENNIFER A. WELMAN, RCE C62260 DATE
 DESIGNED BY JAM
 DRAWN BY CLG
 REVIEWED BY JLW

Coastland Civil Engineering, Inc.
 1400 Neotomas Avenue, Santa Rosa, CA 95405
 707.571.8037 Fax 707.571.8005

CALIFORNIA
 HIDDEN VALLEY LAKE COMMUNITY SERVICES DISTRICT
SEWER REHABILITATION
SITE PLAN & DETAILS

PROJECT NUMBER 99-4413
 DRAWING DATE AUGUST 2020
 SHEET NUMBER 2 OF 2

STANDARD DETAILS
(EASTERN MUNICIPAL WATER DISTRICT)

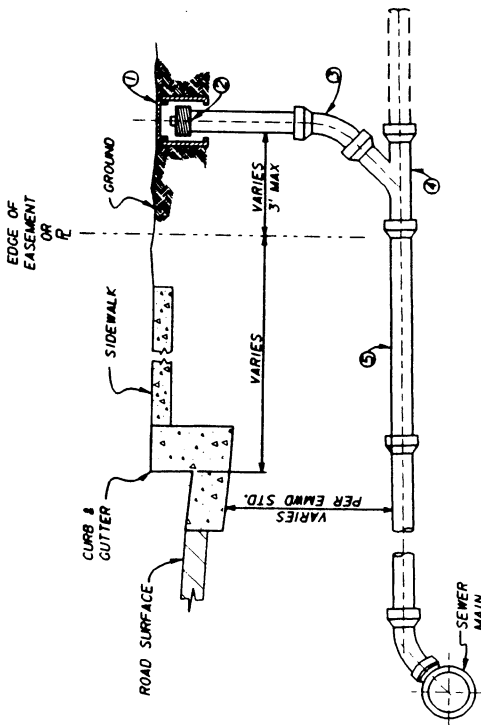

MATERIALS LIST

- ① BROOKS 1-RT VALVE BOX MARKED "SEWER", OR APPROVED EQUAL.
- ② THREADED CAP WITH SQUARE NUT.
- ③ MINIMUM 3-1/2" SEWER PIPE PER UNIFORM PLUMBING CODE.
- ④ WYE PER UNIFORM PLUMBING CODE.
- ⑤ MINIMUM 4" LATERAL, OR AS SHOWN ON PLANS, PER EMD STANDARDS.

ON-SITE CLEANOUT

N.T.S.

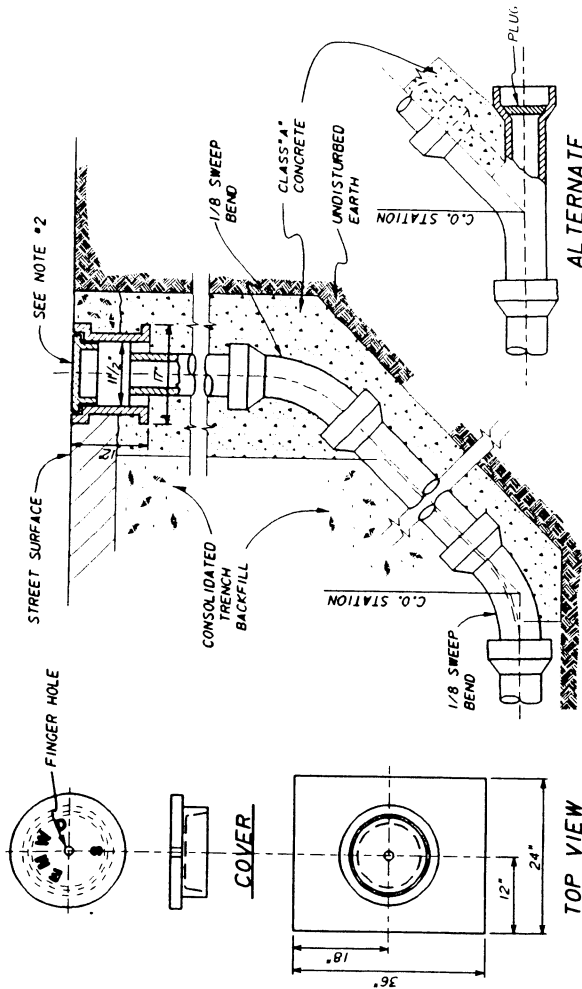

ALTERNATE

FOR LOWER 1/8 BEND WHERE ORDERED BY ENGINEER OR SHOWN ON PLANS

NOTES

1. CLEANOUT PIPE MUST BE THE SAME DIAMETER AND MATERIAL AS MAIN LINE SEWER.
2. CASTING SHALL BE ALHAMBRA FOUNDRY NUMBER A-1241 OR APPROVED EQUAL.
3. COVER, FRAME, AND CONCRETE PAD ARE TYPICAL FOR 8" I.D. MAIN LINE SEWERS ONLY.
4. USE CLASS "A" CONCRETE THROUGHOUT.
5. PLUGS SHALL BE CEMENTED IN PLACE WITH CEMENT MORTAR OR SHALL BE NEOPRENE PLUG OR APPROVED EQUAL.
6. STATION OF LOWER 1/8 BEND OR WYE SHALL CORRESPOND TO THE CLEANOUT STATION SHOWN ON THE CONSTRUCTION DRAWINGS WITH CLEANOUT CONSTRUCTION EXTENDED BEYOND THAT POINT AS NECESSARY.

MAIN LINE CLEANOUT

N.T.S.



EASTERN MUNICIPAL WATER DISTRICT
STANDARD DRAWING

**SEWER CLEANOUTS
MAIN LINE & ON-SITE**

APPROVALS		INITIAL	DATE
DESIGN	CONSTRUCTION	INSPECTION	OPERATIONS
INITIAL	DATE		
SD	8/63		

REFERENCES: SUPERCEDES SA-90
FILE I.D.: /USR/KARL/STNDRS/SB-52

SCALE: NONE
DRAWN BY K.E.R.

RECOMMENDED

DIRECTOR OF ENGINEERING

DATE

8/63

SB-52

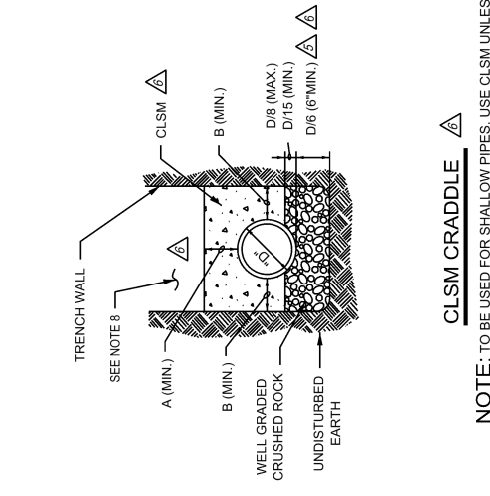
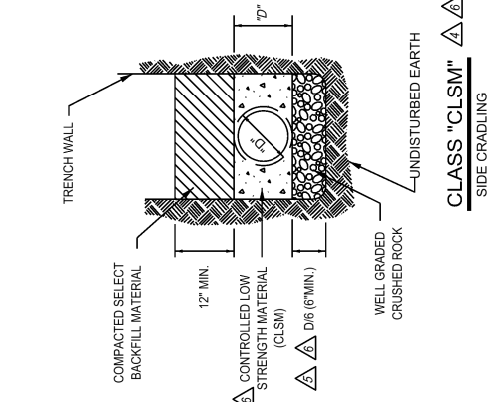
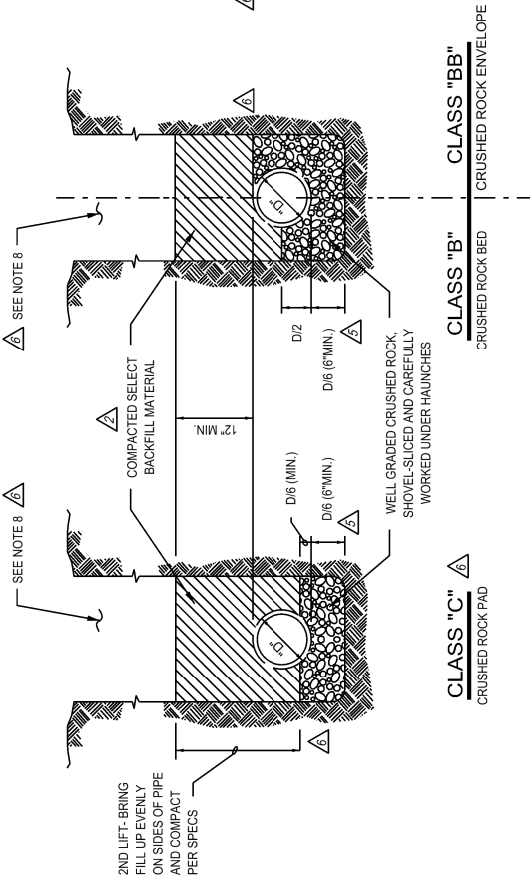

CLSM CRADDLE

NOTE: TO BE USED FOR SHALLOW PIPES. USE CLSM UNLESS OTHERWISE INSTRUCTED BY THE ENGINEER OR AS SHOWN IN THE CONTRACT DRAWINGS.

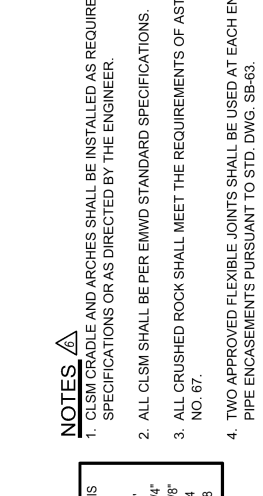
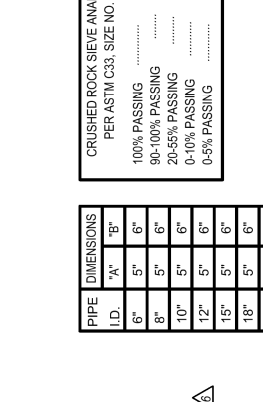
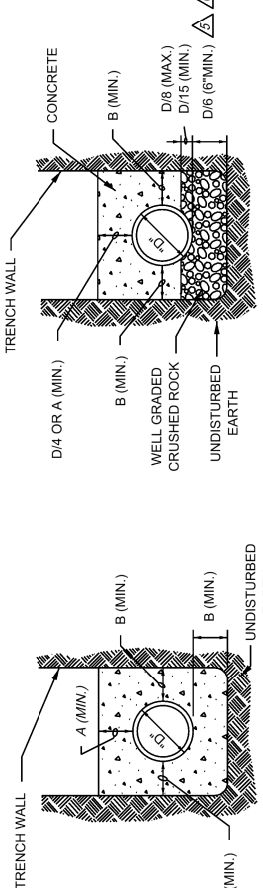

CLSM CRADDLE

NOTE: TO BE USED FOR SHALLOW PIPES. USE CLSM UNLESS OTHERWISE INSTRUCTED BY THE ENGINEER OR AS SHOWN IN THE CONTRACT DRAWINGS.

PIPE DIMENSIONS	
I.D.	A" B"
6"	5" 6"
8"	5" 6"
10"	5" 6"
12"	5" 6"
15"	5" 6"
18"	5" 6"
21"	6" 6"
24"	6" 6"
27"	7" 7"
30"	8" 8"
33"	9" 9"
36"	9" 9"
39"	10" 10"
42"	11" 11"

CRUSHED ROCK SIEVE ANALYSIS PER ASTM C33, SIZE NO. 67	
100% PASSING	1"
90-100% PASSING	3/4"
20-55% PASSING	3/8"
0-10% PASSING	#4
0-5% PASSING	#8

CONCRETE ENCASUREMENT NO.2

NOTE: USE CONCRETE ENCASUREMENT NO.2 UNLESS OTHERWISE INSTRUCTED BY THE ENGINEER, OR AS SHOWN IN THE CONTRACT DRAWINGS.

CONCRETE ENCASUREMENT NO.1

NOTE: REFER TO STD. DWG SB-159 FOR BEDDING CLASSIFICATION

REVISIONS		APPROVALS	
NO.	DATE	INITIAL	DATE
1	4/11/13	GS	4/25/13
2	6/4/19	KER	6/2/19
3	11/4/19	KER	11/2/19
4	2/19/19	KER	2/28/19
5	1/31/19	KER	1/28/19



EASTERN MUNICIPAL WATER DISTRICT
RIVERSIDE COUNTY, CALIFORNIA

PIPE ZONE BEDDING FOR SEWER PIPE

REFERENCES: SUPERCEDES SB-76
FILE I.D.: KAUAI/ENGINEERING/STDDWG

SCALE: NONE
DRAWN BY: KER

RECOMMENDED: Joseph D. Van Sickle, 3/5/19, DIRECTOR OF ENGINEERING

APPROVED: William S. Plummer, 3/8/19, CHIEF ENGINEER

SB-157

UNSURFACED MEDIANS,
ROADSIDE STRIPS,
OR EASEMENTS

UNSURFACED ROADWAYS,
SURFACED STREETS
OR SURFACED EASEMENTS

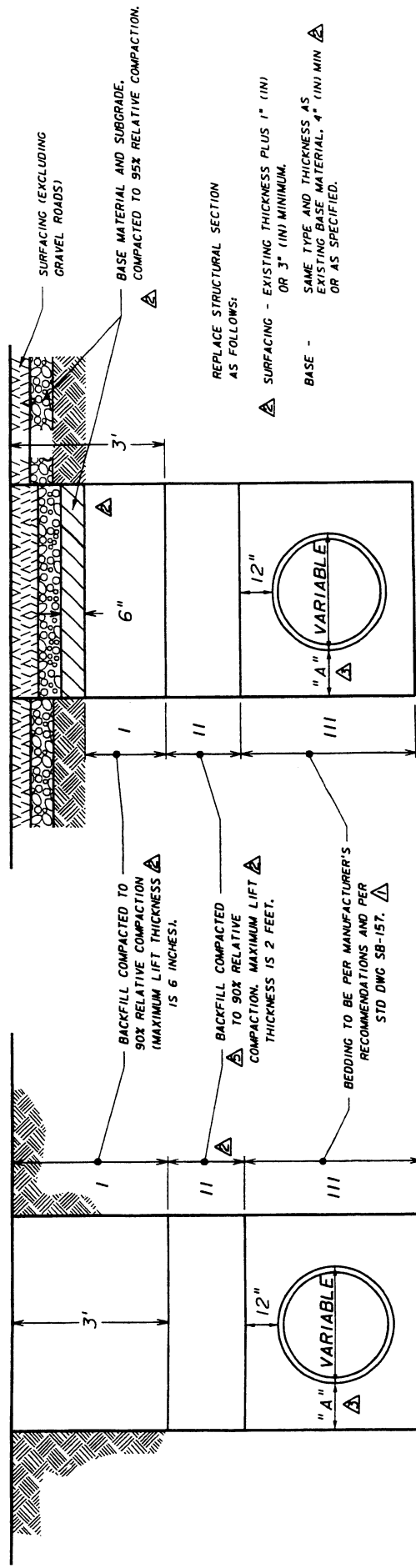

CLEARANCE "A"
1. CLAY PIPE: SEE STD. DWG. SB-159
2. PLASTIC PIPE: PIPE SIZES THROUGH 12" - "A" = 6"-9"
PIPE SIZES OVER 12" - "A" = 1'-0" MIN.

REPLACE STRUCTURAL SECTION AS FOLLOWS:
SURFACING - EXISTING THICKNESS PLUS 1" (IN) OR 3" (IN) MINIMUM.
BASE - SAME TYPE AND THICKNESS AS EXISTING BASE MATERIAL, 4" (IN) MIN OR AS SPECIFIED.

NOTE: WHEN A FIRM FOUNDATION IS NOT ENCOUNTERED, DUE TO SOFT, SPONGY, OR OTHER UNSUITABLE MATERIAL, SUCH MATERIAL SHALL BE REMOVED TO THE LIMITS DIRECTED BY THE ENGINEER, AND THE RESULTING EXCAVATION BACK-FILLED WITH PIPE BEDDING MATERIAL COMPACTED TO 90% RELATIVE COMPACTION.

REVISIONS		APPROVALS	
NO.	DATE	INITIAL	DATE
1	7/15/93	UAB	7/22/93
2	1/31/95	UAB	2/2/95
3	7/11/95	UAB	7/13/95
4	2/19/97	UAB	7/28/97
5	10/15/03	UAB	10/17/03

DESIGN	CONSTRUCTION	INSPECTION	OPERATIONS	SUBMITTED
				UAB 3/19/93

RECOMMENDED Joseph D. Van Sickle 3/5/93 DATE
 DIRECTOR OF ENGINEERING

SCALE: NONE
 DRAWN BY KER



EASTERN MUNICIPAL WATER DISTRICT
STANDARD DRAWING

**TRENCH BACKFILL
FOR SEWER PIPE**

APPROVED William E. Plummer 3/8/93 DATE
 CHIEF ENGINEER

FILE I.D.: m:\graphics\visio\mfm\standord dwg\sb158.dgn

SB-158 A

HIDDEN VALLEY LAKE COMMUNITY SERVICES DISTRICT

2020 - 2021 DEBT SERVICE

JULY 2020

	DEBT SERVICE REVENUE	FUND	AMOUNT
1)	1995-2 BOND - TAX ASSESSMENT	215	\$ 300,224
2)	CIEDB LOAN - WATER INFRASTRUCTURE	130	170,746
3)	USDA LOAN - SOLAR PROJECT WWTP	120	32,255
	TOTAL DEBT SERVICE REVENUE		\$ 503,225

	DEBT SERVICE EXPENSE	FUND	DEBT AMOUNT	PAID TO DATE
1)	1995-2 BOND REDEMPTION (PRINCIPAL)	215	\$ 185,000	\$ -
	1995-2 BOND REDEMPTION (INTEREST)	215	99,994	-
	BOND ADMINISTRATION (ANNUAL FEE)	215	7,460	1,864.22 7/2/2020
	COUNTY COLLECTION FEES	215	3,500	-
	CSD ADMIN COSTS	215	4,270	-
			\$ 300,224	\$ 1,864.22

2)	CIEDB (PRINCIPAL)	218	\$ 110,065	\$ -
	CIEDB (INTEREST)	218	55,865	27,932.73 7/17/2020
	CIEDB (ANNUAL FEE)	218	4,816	-
			\$ 170,746	\$ 27,932.73

3)	USDA RUS LOAN (PRINCIPAL)	219	\$ 17,000	\$ -
	USDA RUS LOAN (INTEREST)	219	15,255	-
			\$ 32,255	\$ -

TOTAL DEBT SERVICE EXPENSE

\$ 503,225 \$ 29,796.95

**ACTION OF
HIDDEN VALLEY LAKE COMMUNITY SERVICES DISTRICT**

DATE: August 18, 2020

AGENDA ITEM: Authorize Staff to Accept AnteaGroup Exposure Monitoring Proposal in support of OSHA abatement requests

RECOMMENDATIONS: Authorize Staff to Accept AnteaGroup Exposure Monitoring Proposal in support of OSHA abatement requests.

FINANCIAL IMPACT: \$6,500

FUND/AMT: 120-5-00-5315 or 120-5-00-5150

BACKGROUND:

After a surprise visit on 5/29, a series of document requests, and a several emails of progress and clarifications, OSHA has submitted their list of Findings and Questions for abatement/correction. Of the ten listed items in this email sent on 8-7-20, numbers 8-10 were topics first suggested to the District on 7-9-20. The District has acted upon those items since the first notification in July.

Regarding the issue of employee exposure during chlorine container changeouts, OSHA had determined that full Self-Contained Breathing Apparatus' (SCBAs) were required during this procedure. This determination was based on the lack of Industrial Hygiene Sampling. Presumably this sampling would prove that the air in the breathing zone of the employee while changing out a chlorine container was safe enough to warrant the use of a full facemask with air filter, not SCBAs. After suggesting this abatement path of sampling, OSHA's response was as follows:

"To conduct industrial hygiene sampling, employer needs to ensure, for the adequate protection of employees, the person supervising, directing or evaluating the monitoring and control methods shall be competent in industrial hygiene practice."

Staff recognizes the importance of testing air quality to ensure the safety of its employees and has therefore reached out to the Certified Industrial Hygienists (CIH) of Antea Group for assistance. This Exposure Monitoring proposal is comprised of two tasks: 1. Chlorine Gas Exposure Assessment, and 2. Chlorine Monitoring Equipment Training. Once the Antea CIH has tested the air, they will be teaching staff how to use existing monitoring equipment to continue the sampling.

By proving air safety during the changing of chlorine containers, the use of full facemask and air filter can continue to be used. The District would then not be required to change the RMP Container Changeout procedure, the Emergency Response Plan, or the Personal Protective Equipment definition.

Modification to recommendation and/or other actions:

I, Penny Cuadras, Secretary to the Board, do hereby certify that the foregoing action was regularly introduced, passed, and adopted by said Board of Directors at a regular board meeting thereof held on August 18, 2020 by the following vote:

Ayes:

Noes:

Abstain:

Absent

Secretary to the Board

Introduction

Antea Group is pleased to provide Hidden Valley Lake Community Services District with this proposal for Environmental, Health, and Safety (EHS) related consulting services at its wastewater treatment facility located at 19400 Hartmann Rd, Hidden Valley Lake, CA 95467. Based on recent discussions related to the chlorine gas exposure concerns voiced during a CalOSHA visit on May 29th, Antea Group proposes the completion of chlorine gas exposure monitoring for the employees replacing the chlorine gas tanks and the provision of training to these employees for the chlorine gas monitoring devices worn during the tank replacement process. A Certified Industrial Hygienist, or Industrial Hygiene technician under the supervision of a CIH, is scoped to provide the described services.

Scope

Antea® Group is pleased to provide Hidden Valley Lake Community Services District (HVLCSO) with this proposal for environmental, health, and safety consulting services. Specifically, Antea Group has prepared this proposal based on recent discussions related to the chlorine gas exposure concerns voiced during a CalOSHA visit on May 29th at the wastewater treatment facility located at 19400 Hartmann Rd, Hidden Valley Lake, CA 95467. Antea Group proposes the completion of chlorine gas exposure monitoring for the employees replacing the chlorine gas tanks and the provision of training to these employees for the chlorine gas monitoring devices worn during the tank replacement process. The work will be completed under the terms and conditions of the HVLCSO/Antea Group Master Services Agreement.

Task 1 – Chlorine Gas Exposure Assessment

Antea Group proposes to conduct an exposure assessment of chlorine gas during the chlorine gas tank replacement process at the facility. The exposure assessment will be performed by an Antea Group Certified Industrial Hygienist (CIH), or a technician under the supervision of a CIH. Our field activities will include the mobilization of the sampling

Antea Group specializes in environmental, health and safety consulting, and international engineering. Our firm partners with clients to provide full-service, tailored workplace solutions. With more than 5,000 employees in over 150 offices around the world, we serve clients ranging from global energy companies, technology providers, and manufacturers to national governments and local municipalities.

A company strategy of proper recognition, evaluation, and control of the industrial worker's environment proactively manages an organization's health and safety risks. Risk management strategies minimize the potential damage to people, company reputation and the bottom line. These are key components of our clients' core values, and philosophies critical to stakeholders, customers and the community.

Our Certified Safety Professionals and Certified Industrial Hygienists will design and implement health & safety solutions that are strategically aligned with both your business goals and regulatory requirements. We analyze health and safety risks and assist you with developing a strategy to control and prevent potential health hazards within the workplace.

By combining strategic thinking and multidisciplinary perspectives with technical expertise and pragmatic action, we do more than effectively solve client challenges; we deliver sustainable results for a better future. By understanding today, we are improving tomorrow.

equipment, media preparation, collecting the samples for the designated staff, documenting field conditions and activities, conducting periodic checks on the sampling equipment, troubleshooting issues that may arise, collecting the samples and equipment at the end of the sampling periods, and shipping samples needing analysis to the laboratory.

All monitoring will be performed using methods recognized by the Occupational Safety and Health Administration (OSHA) or National Institute for Occupational Safety and Health (NIOSH). Samples requiring analysis will be submitted to a laboratory accredited by the American Industrial Hygiene Association (AIHA). Samples will be analyzed using standard turn-around-times (generally two weeks or less). Monitoring results will be compared to applicable CalOSHA, Federal OSHA, ACGIH, NIOSH, or other recognized occupational exposure limits.

Antea Group will provide a draft Exposure Assessment Report summarizing the sample results, any conclusions that can be made based on the analytical results, and our recommendations for further actions, if applicable.

Task 2 – Chlorine Monitoring Equipment Training

While onsite, Antea Group will provide training on the currently owned/used chlorine direct reading instruments for to up to six (6) employees. The training will include how to calibrate, maintain, use, and datalog the chlorine monitoring equipment used on-site and answering any questions the employees may have.

Scheduling: Antea Group will begin this assignment on a mutually agreed upon date and time following authorization of the scope of work, and fully executing the Continuing Services Agreement included as Appendix A, or a Master Services Agreement provided by HVLSCD. Antea Group understands that the chlorine tank replacements occur monthly. Antea Group will plan to be onsite to collect a sample on the next scheduled replacement date of August 21, 2020. Antea Group will work in close collaboration with Alyssa Gordon throughout the project. The draft report will be submitted to the client within two weeks of the receipt of the analytical results.

Project Effort and Cost: Antea Group proposes to complete this project on a **time and materials basis**. Labor will be billed at the following rates, and expenses will be billed at cost plus 15% markup. The estimated cost for Task 1 and 2 is **\$6,500**.

Terms and Conditions: The above-described work will be performed in accordance with the terms and conditions established by Antea Group's Continuing Services Agreement (Appendix A) or by a Master Services Agreement between Universal Cells and Antea Group. This proposal is valid for thirty (30) days from the date of issue. We will invoice monthly, with payment of invoices expected within thirty days of issue date.



Closing: We appreciate the opportunity to provide this proposal for your consideration and look forward to working with you on this assignment. Should you have any questions regarding the proposal, please feel free to contact me.

Please indicate your acceptance of this proposal by signing the authorization below and returning a copy by mail or email to the undersigned at Theresa.mccollom@anteagroup.us.

A handwritten signature in black ink, appearing to be "T. McCollom", written over a horizontal line.

Theresa McCollom, M.S., CIH, CSP, ASP

Antea Group

Senior Project Manager

303.513.9536

Theresa.mccollom@anteagroup.us



Proposal Authorization

Title of Proposal: Chlorine Gas Exposure Assessment

Proposal Number: 2020-08-420860

Proposal Date: 8/10/20

The scope of work and cost estimate is acceptable, and our signature below is authorization to proceed.

Client Authorization - Signature

Antea Group Authorization - Signature

Date

Date

Appendix A –Continuing Services Agreement

ANTEA USA, INC.
CONTINUING SERVICES AGREEMENT FOR CONSULTING SERVICES
NOT INCLUDING ANY SAMPLING OR INTRUSIVE FIELD WORK

THIS AGREEMENT is effective on the ____ day of ____, 20__, by and between ____ ("Client") and Antea USA, Inc. ("Consultant") for environmental consulting services that Consultant will perform from time to time at Client's written request.

SCOPE OF SERVICES

Consultant will provide environmental support services to Client on a non-exclusive basis on the terms and conditions provided in this Agreement and as specifically described in Client's written request for environmental consulting services ("Work"). Client may request Work under this Agreement only in writing, through an activating letter/purchase order signed by one of the following people: _____.

If Client issues an activating letter / purchase order to Consultant then Consultant shall accept or reject the requested Work in writing within five days of receipt of the activating letter / purchase order. If Consultant accepts Work, Consultant will begin the Work promptly on the date specified in the activating letter / purchase order unless otherwise mutually agreed.

This Agreement covers services provided to Client by Consultant that do not involve sampling or intrusive field work. In the event that sampling or intrusive field work services are needed, Client agrees to enter into a Standard Consulting or Continuing Services Agreement with Consultant to cover those services.

COMPENSATION

Client agrees to pay Consultant for the Work pursuant to Attachment I. Client agrees to pay for any services that are (a) required because of a material increase in the scope of the Work or (b) requested in addition to the Work as provided in Attachment I. Attachment I will continue to be effective until the ____ day of ____, 20____. Thereafter, Consultant may increase its fees, provided that increases may not be made more frequently than once each year. Consultant will notify Client of any increase in fees 30 days prior to its effective date.

This Agreement is subject to the following General Conditions:

SECTION 1: FEE PAYMENT

- 1.1** Consultant will submit invoices to Client monthly with a final invoice on completion of the Work or at such other times as specifically provided in Attachment I.
- 1.2** Payment is due upon receipt of invoice. If the invoice is not paid within thirty (30) days after invoice date, Client will also pay a finance charge thereon of 1.5 percent or the maximum rate allowed by law, whichever is less, for each month thereafter or portion thereof that an invoice remains unpaid.
- 1.3** If Client fails to pay Consultant within sixty (60) days after invoice date, Consultant may deem failure to pay a breach of this Agreement, terminate the same, and be relieved of any and all duties under this Agreement.

SECTION 2: PROJECT INFORMATION

- 2.1** Client will provide to Consultant in writing information known to Client regarding existing and proposed conditions of the Site. The information will include without limitation, but only as appropriate to the work, reproducible record drawings, mechanical drawings, construction specifications, operating and performance criteria for mechanical systems, site plans, topographic surveys and mapping, property line surveys, hydrologic data, subsurface or latent physical conditions at the Site, previous soil data including borings, field or laboratory tests, and written reports, material safety data sheets for any chemical or material which Consultant may encounter on site if that chemical or material is one for which the Client or its vendors are required by law to supply a material safety data sheet, and notice of all known hazardous, toxic, radioactive, pollutant, or irritant conditions at the Site ("Project Information").
- 2.2** Client will immediately transmit to Consultant any updates, revisions, or additions to the Project Information as they become available to it or its consultants.

SECTION 3: OWNERSHIP OF DOCUMENTS CONFIDENTIALITY, AND PATENTS AND COPYRIGHTS

- 3.1** Consultant will prepare and deliver to Client certain reports, drawings, plans, designs, or specifications as instruments of the professional services performed ("Reports"). All Reports delivered to Client will become the property of Client upon final payment due Consultant for the Work. Consultant may retain copies of the Reports for its files.
- 3.2** Client agrees that all Reports furnished to the Client that are not paid for will be returned to Consultant upon written demand by Consultant and will not be used by Client for any purpose.
- 3.3** Consultant will retain Reports and all pertinent records ("Records") relating to the Work for a period of three (3) years after the Report is delivered. During that time, the Reports and Records will be made available to Client during Consultant's normal business hours.

3.4 Reports and Records are not suitable for use or reuse by Client, its employees, agents, or subcontractors on any continuation or extension of the Work or on any other project without the written consent of Consultant. This consent is required to permit Consultant to evaluate Report and Record applicability under new circumstances such as, but not only, passage of time. Client agrees to indemnify, defend, and hold Consultant harmless from and against any and all claims, damages, losses, and expenses, including reasonable attorney's fees, awards, fines, or judgments arising out of or resulting from the unauthorized reuse of any Reports or Records.

3.5 All Reports, Records, and Project Information disclosed or delivered to Consultant or information that Consultant uncovers, acquires, or generates in the course of performing the Work will be treated by Consultant as confidential information and will not be disclosed or made available to others by Consultant without prior consent of Client. The foregoing obligation will not apply to any information that Consultant establishes: (a) is already known to Consultant at the time of its receipt from Client as shown by Antea USA, Inc.'s records, (b) is or subsequently becomes available and accessible to the public through no fault of Antea USA, Inc., (c) is disclosed to Consultant by a third party on a non-confidential basis, (d) is deemed necessary by Consultant to warn of an imminent danger to life or property, or (e) is required to be disclosed pursuant to legal process, subpoena, court order, applicable law, or agency regulation.

3.6 Notwithstanding any other provision to the contrary, Consultant retains the right of ownership of any patentable or copyrightable concepts arising from its services.

SECTION 4: STANDARD OF CARE

4.1 Consultant will perform the Work consistent with that level of care and skill ordinarily exercised by members of its profession currently practicing under similar conditions.

4.2 Consultant will not be responsible for the interpretation of its data by others.

SECTION 5: INDEMNIFICATION AND LIMITATION OF LIABILITY

5.1 Client and Consultant each agree to indemnify and hold the other (and its officers, employees, and agents) harmless for losses resulting from and to the extent of its own negligence or willful misconduct, except as provided in Section 5.2.

5.2 Client recognizes that certain federal, state, or local laws or regulations provide that where multiple parties are considered responsible for any hazardous, toxic, radioactive, pollutant, or irritant condition ("Condition") each may be held liable for the Condition under the doctrines of joint and several liability or strict liability. Client agrees that it is not the purpose of this Agreement that Consultant be exposed to any liability arising out of any pre-contract Condition at the Site, the activities of others, or the non-negligent performance by Consultant of the Work. Accordingly, Client waives any claims and agrees to indemnify, defend, and save harmless Antea USA, Inc., its agents, employees, or subcontractors from any demands, suits, judgments, expenses, attorney fees, and losses by reason of any injury to persons, death, or damage to property arising in connection with any Condition at the Site. This obligation exists irrespective of whether the Condition was generated or introduced before or after the execution of this Agreement or whether Client was aware of or involved in the generation or introduction of the Condition. This obligation does not apply to any Condition brought to the Site by Consultant or to the extent Consultant negligently contributed to any Condition.

5.3 Client and Consultant each agree that neither will be responsible either in contract or tort, for any incidental, indirect, punitive or consequential damages (including loss of profits or business interruption) sustained by the other, its



successors or assigns whether or not the possibility of such damages has been disclosed to the other party in advance or could have been reasonably foreseen by such other party.

5.4 Nothing herein will be deemed a waiver of any statutory limitation of liability or any obligation set out in this Agreement.

5.5 Consultant's liability for claims (other than claims covered by Consultant's obligation to the Client under Section 5.1) will not exceed payments received from the Client for the Work.

SECTION 6: INSURANCE

Consultant will carry: (a) workers' compensation and employer's liability insurance to comply with laws of the state in which any project is undertaken by Consultant under this Agreement and applicable Federal laws, (b) comprehensive general liability insurance with a combined limit for bodily injury and property damage in an amount not less than \$1 million per occurrence and \$2 million aggregate and with completed operations coverage having a \$1 million aggregate limit, (c) comprehensive automobile liability insurance, covering all automobiles, trucks, and miscellaneous powered and automotive equipment owned or used by Antea USA, Inc., with a combined limit for bodily injury and property damage in an amount not less than \$1 million per occurrence, (d) pollution liability insurance, in an amount not less than \$1 million per occurrence and \$1 million in aggregate, and (e) professional liability insurance, in an amount not less than \$1 million per occurrence and \$1 million in aggregate. Client will be named as an Additional Insured on b, c and d. Each insurance policy required herein shall waive rights of subrogation against client as required by contract. Client will be provided a Certificate of Insurance outlining the coverages contained in this section 6. Antea USA, Inc.'s liability for damages arising from occurrences covered by these policies of insurance will not exceed the coverage provided therein.

SECTION 7: ATTORNEY'S FEES

In the event of any controversy, claim, dispute, or litigation between the parties related to this Agreement or its breach, the prevailing party will be entitled to recover from the other party, in addition to other relief as may be granted, a reasonable sum as and for its attorney's fees together with expert's fees and other costs incurred as may be determined by a court of competent jurisdiction. Client also agrees to pay all costs of collection, including reasonable attorney's fees, in the event payment is not received as provided herein; this liability for attorney fees is not contingent upon suit being filed by Antea USA, Inc.

SECTION 8: SITE LOCATION/ ACCESS/ PERMITS AND APPROVALS

- 8.1** Client will delineate to Consultant the property lines of the Site.
- 8.2** Client will provide access to the Site for Consultant personnel and equipment as Consultant may deem necessary to complete the Work.
- 8.3** Should it be necessary for Consultant to enter onto a third party's property to perform any of the Work, Client shall be solely responsible for gaining such access.

SECTION 9: FORCE MAJEURE



If completion of any portion of the Work is delayed for causes beyond the control of or without the fault of Consultant including Force Majeure, the time of performance of the Work will be extended for a period equal to the delay. Force Majeure includes, without limitation, acts of God; acts of the public enemy; acts of federal, state, local, or foreign governments; acts of Client's subcontractors or agents; fires; floods; epidemics; strikes; riots; freight embargoes; and unusually severe weather.

SECTION 10: TERMINATION

10.1 This Agreement may be terminated by either party upon seven (7) calendar days written notice unless specifically instructed otherwise, upon termination by Client, Consultant will continue work under any outstanding activating letter / purchaser orders through completion. If the Work is suspended for more than three (3) months, or if this Agreement is terminated by Client and Consultant is directed to stop Work on an outstanding activating letter / purchase order, Consultant may complete analyses that are in progress, and may also complete a summary report on the Work done prior to termination.

10.2 Upon termination, Consultant will be paid for services, the completion of any outstanding activating letter/purchase orders, plus reasonable termination expenses, which expenses will include direct costs of completing the analyses, and summary report referred to above.

SECTION 11: ASSIGNMENT

Neither party may delegate duties or assign interest in this Agreement without obtaining the prior written consent of the other party, which consent will not be unreasonably withheld, except Consultant may use the services of persons and entities not in its employ when it is customary for Consultant to do so. These may include, without limitation, surveyors, specialized consultants, drilling contractors, testing laboratories, and construction contractors.

SECTION 12: ANTEA USA, INC.'S SUBSIDIARIES / EFFECTIVE CONTRACT

"Antea USA, Inc.", shall mean Antea USA, Inc., Antea USA of Michigan, Inc., Antea USA of North Carolina, Inc., Antea USA of Ohio, Inc., Antea USA of Illinois, Inc., or any other Antea USA, Inc., wholly-owned subsidiary. All rights and obligations under this Agreement shall run to Antea USA, Inc., or its wholly-owned subsidiary or whichever performs the Work.

SECTION 13: MISCELLANEOUS

13.1 The section headings of this Agreement are included for purposes of convenience only and will not affect the construction or interpretation of any provision.

13.2 The parties acknowledge that this Agreement supersedes all written and oral agreements, if any, between the parties, and that this Agreement constitutes the entire and only agreement pertaining to the Work.

13.3 This Agreement will be binding upon and will inure to the benefit of the parties and their successors and assigns.

13.4 This Agreement will be construed, the rights and obligations created hereby will be governed, and the remedies available will be provided in accordance with the laws of the state in which the Work is performed, regardless of the conflict of law principles customarily applied by the courts of any jurisdiction. Venue and adjudication will be in that state.



13.5 Any of the terms or conditions of this Agreement may be waived at any time by the party that is entitled to benefit therefrom, but no waiver will affect or impair the right of the waiving party to require observance, performance, or satisfaction of any other term or condition hereof. Any of the terms or provisions of this Agreement may be amended or modified at any time by agreement in writing executed by each party hereto.

13.6 All provisions of this Agreement allocating responsibility between Client and Consultant will survive the completion of the Work or termination of this Agreement.

13.7 Any provision or part of this Agreement adjudicated to be void or unenforceable under any law will be deemed deleted, such deletion to apply only with respect to the jurisdiction in which such adjudication is made, and all remaining provisions will continue to be valid and binding upon the parties. The parties agree that this Agreement will be reformed to replace the deleted provision or part thereof with a valid and enforceable provision that comes as close as possible to expressing the intention of the deleted provision.

13.8 In keeping with the intent of the parties that this is the entire Agreement between them, the parties agree that the preprinted terms and conditions of any Client activating letter/purchase order issued to request Work pursuant to this Agreement will not apply to the Work, regardless of whether Consultant executes the activating letter/purchase order in acceptance of the Work.

13.9 Client has authority to enter into this Agreement and any person signing it on Client's behalf has been duly authorized to sign.

13.10 Client and Consultant shall not perform any actions that are prohibited by federal, state, local and other anti-corruption laws (collectively "Anti-Corruption Laws") applicable to the Agreement. Without limiting the foregoing, Client and Consultant shall not make any payments, or offer or transfer anything of value, to any government official or government employee, to any political party official or candidate for political office or to any other third party related to the transaction in a manner that would violate Anti-Corruption Laws.

WHEREUPON, the parties caused this Agreement to be duly executed and to be effective on the date first above written.

SIGNATURES

Antea USA, Inc.

Signature

Name

Title



Client

Address

Signature

Name

Title

FY 20-21 Utility Billing Aging Report

Year	Month	Current	+1	+2	+3	+4	Balance
2020	31-Jul	\$ 285,960	\$ 40,153	\$ 19,266	\$ 12,354	\$ 46,551	\$ 404,285
2020	31-Aug						
2020	30-Sep						
2020	31-Oct						
2020	30-Nov						
2020	31-Dec						
2021	31-Jan						
2021	29-Feb						
2021	31-Mar						
2021	30-Apr						
2021	31-May						
2021	30-Jun						

Residential Aging Report - Fiscal Year Comparison

Billing Year	Billing Month	Billing Revenue	Past Due +1 Month	Past Due +2 Months	Past Due +3 Months	Past Due +4 Months	Fiscal Year End TOTAL PAST DUE AMT
2020	July 2020	\$ 285,960	\$ 40,153	\$ 19,266	\$ 12,354	\$ 46,551	\$ 118,325
2019	July 2019	\$ 295,883	\$ 36,766	\$ 1,925	\$ 935	\$ 19,891	\$ 59,517
Percentage Difference:		-3%	9%	901%	1221%	134%	99%
Delinquency Difference:			\$ (3,386.80)	\$ (17,341.45)	\$ (11,419.14)	\$ (26,660.24)	\$ (58,807.63)

FY 19-20 Utility Billing Aging Report

Year	Month	Current	+1	+2	+3	+4	Balance
2019	31-Jul	\$ 295,883	\$ 36,766	\$ 1,925	\$ 935	\$ 19,891	\$ 355,401
2019	31-Aug	\$ 293,153	\$ 37,274	\$ 3,532	\$ 1,333	\$ 17,838	\$ 353,133
2019	30-Sep	\$ 274,248	\$ 51,092	\$ 3,515	\$ 2,165	\$ 18,013	\$ 349,033
2019	31-Oct	\$ 248,736	\$ 42,438	\$ 9,316	\$ 2,570	\$ 19,669	\$ 322,730
2019	30-Nov	\$ 224,059	\$ 53,330	\$ 3,567	\$ 3,129	\$ 21,784	\$ 305,870
2019	31-Dec	\$ 220,403	\$ 38,310	\$ 3,431	\$ 1,562	\$ 23,915	\$ 287,623
2020	31-Jan	\$ 216,057	\$ 33,745	\$ 2,846	\$ 2,441	\$ 24,804	\$ 279,895
2020	29-Feb	\$ 218,104	\$ 43,077	\$ 15,243	\$ 2,201	\$ 24,866	\$ 303,492 SB 998
2020	31-Mar	\$ 231,486	\$ 38,864	\$ 15,867	\$ 9,990	\$ 25,446	\$ 321,656 N-42-20
2020	30-Apr	\$ 233,212	\$ 36,973	\$ 16,365	\$ 10,399	\$ 32,419	\$ 329,367 N-42-20
2020	31-May	\$ 244,276	\$ 42,493	\$ 18,546	\$ 11,598	\$ 39,861	\$ 356,774 N-42-20
2020	30-Jun	\$ 291,551	\$ 42,860	\$ 19,524	\$ 12,197	\$ 44,504	\$ 410,638 N-42-20

**ACTION OF
HIDDEN VALLEY LAKE COMMUNITY SERVICES DISTRICT**

DATE: August 18, 2020

AGENDA ITEM: Approve and Adopt Mobile/Stationary Meter Use Policy and Resolution 2020-10 Adopting Mobile and Stationary Meter Use fees

RECOMMENDATIONS: Approve and Adopt Mobil/Stationary Meter Use Policy

FINANCIAL IMPACT: This policy and resolution will help the District appropriately recover rate revenue for these services and ensure other customers are not subsidizing these costs. Among other things, this policy will protect the District against water theft.

FUND/AMT: N/A

BACKGROUND:

September 2015: The Valley Fire decimated the community and its landscape. In an effort to help rebuild, the District implemented the sale of bulk water from a fire hydrant. The cost of this water did not include any protection against or provision for damage or theft. As a shared water resource, tracking individual customer use became challenging.

Over time, this privilege became a drain on administrative resources. It has become apparent that bulk water customers' commitment to security has been lacking.

The potential for damage to the District's water distribution system, and insufficient costing measures has prompted the District to develop the more stringent Mobile/Stationary Use Policy presented here. The permit issued to a bulk water user requires the acknowledgement of user responsibility, and the use of appropriate equipment.

Based on NBS recommendations for an equitable volumetric rate, the per hundred cubic feet (HCF) charge will be \$6.70/HCF. This figure is derived from the NBS 2015 Rate Study that identifies both fixed and variable costs for the District that should be charged to non-residential water sales of the mobile or stationary meter. To meet Prop 218 requirements to demonstrate the cost basis for water utility rates, this volumetric rate includes the revenue normally recovered from water customers through their fixed monthly charges. To meet guidelines established with Ordinance 57.1, fees will be adopted by Resolution. Once the District updates the water rates in the coming months, this volumetric rate will also need to be updated.

Administration costs, and deposit are an added security for fair pricing and responsible behavior.

Modification to recommendation and/or other actions:

I, Penny Cuadras, Secretary to the Board, do hereby certify that the foregoing action was regularly introduced, passed, and adopted by said Board of Directors at a regular board meeting thereof held on August 18, 2020 by the following vote:

Ayes:

Noes:

Abstain:

Absent

Secretary to the Board



POLICY TITLE:	Mobile/Stationary Meter Use	
POLICY #: 1002	ADOPTED DATE: August 18, 2020 President: Jim Lieberman	REVISION DATE: President:

The Board of Directors revised and/or adopted this policy at its public meeting on the latest revision date. This version of the Policy, supersedes all other previous versions.

1002.1 PURPOSE

The mission of the Hidden Valley Lake Community Services District is "to provide, maintain and protect our community's water." In accordance with the spirit of this mission, permitted mobile or stationary meter use is limited to authorized individuals only. The strict control of mobile or stationary meter use is designed to protect the water distribution system integrity, water quality, and the preservation of fire protection.

1002.2 POLICY

TERMS

The following requirements represent the terms of the Mobile/Stationary Meter Use Policy:

- Meter Use Permits are issued for a term not to exceed 180 days (6 months)
- Tankers/containers must only be used for water hauling purposes
- All tanks/containers must have an approved check valve or air gap assembly on fill line.
- Stationary Permit holders must only operate a stationary meter with an approved fire hydrant wrench
- Stationary Permit Holders must open and close hydrant very slowly
- Stationary Permit Holders are expected to replace all caps on the fire hydrant before leaving
- Mobile Permit Holders will connect only to authorized water sources
- Mobile Permit Holders cannot use meter as a substitute for a domestic water source, for agricultural purposes without prior written approval
- Mobile Permit Holders must furnish meter outlet adapters, compatible to NSFT threads
- HVLCSD reserves the right to restrict permits during droughts.

FEES

Prior to the issuance of a Meter Use Permit the following fees are due:

Application/Permit Processing	\$40
Volumetric Rate	\$6.70/HCF
Deposit (refundable upon permit return)	\$3,200
Total initial costs:	\$3,240

*Consumption costs will be billed monthly, until permit expiration. Cost are calculated per hundred cubic feet.

Violations and penalties

Any person involved in the unauthorized use of water will be charged for: the water taken, the costs incurred to investigate and correct the use, penalty fees and other remedies authorized by law or approved by HVLCSD. Those involved in unauthorized use are ineligible for new permits until paying for past water use and penalties.

Meter use violation penalties:

- 1st violation: \$500.
- 2nd violation: \$1,000.
- 3rd violation: \$1,500 and a 90-day suspension of all active permits.

If the meter is lost or stolen the Permit holder will be required to reimburse the District for the actual cost of a new meter.

The District reserves the right to terminate meter use permits at any time, without notice, in matters of misuse, harm to District facilities, interference with the public water supply, or failure to notify of any change in use or any failure to comply with other terms or protocols of this policy.

Accounts unpaid in excess of the deposit will be billed to the Permittee.

PROTOCOLS

The Permit applicant should be prepared to:

- Submit a Nobile/Stationary Meter Use Permit application to the HVLCSD Administration office
- Pay all fees, charges and deposits at the time of application submission
- Be prepared to meet HVLCSD Field Operations personnel within 24 hours of application, for vehicle and tool inspection.

Approved and Adopted on:

Jim Lieberman
President to the Board of Directors

Attest: _____
Penny Cuadras
Secretary to the Board of Directors



HIDDEN VALLEY LAKE
COMMUNITY SERVICES DISTRICT

MOBILE/STATIONARY METER USE PERMIT APPLICATION

Date: _____

Applicant Name: _____ Phone # _____

(please print)

Applicant Mailing Address: _____

Purpose & Location of Water Use _____

I hereby acknowledge and accept the purpose, terms, and protocols of the Mobile/Stationary Meter Use Permit Policy #1002, and pledge to meet all requirements of said document, and this application.

I understand I am solely responsible for the meter and condition while connected, and therefore responsible for any damage or theft while using the meter during the duration of the permit.

I understand that deposit and processing costs are due immediately, and that I will be billed monthly for consumption costs until permit expiration.

Stationary Meter: I understand, upon completion of this Meter Use application, that each and every draw of water will be reported to the HVLCS D Administration Building immediately upon completion of draw. As this is a SHARED meter, I understand that any delay of consumption reporting may result in a higher than expected consumption cost to me. In the event that water needs to be drawn during weekend days, I understand that I assume all costs of an after-hours Field Operator for unlock, lock, and meter read recording. *

Mobile Meter: I understand, upon completion of this Meter Use application, that I am responsible for all water delivered through my assigned meter. I understand that this meter must be made available to Field Operations staff on the last week of every month in order to read consumption.

***** Total processing and deposit costs of \$3,240.00******

*Please refer to <https://www.hvlcsd.org/miscellaneous-fees-and-charges> for after hours service call costs. Costs will also include an hourly accrual of the Field Operator's time.

**Volumetric rates pursuant to the April 2019 NBS Rate Study. Future revision of volumetric rates will appear on the District's website:<https://www.hvlcsd.org/miscellaneous-fees-and-charges>

Signature: _____

For HVLCS D Use Only

Service order# /Address: _____

Date of Permit: _____

Inspection approved: Y / N

Permit Expiration: _____

Starting read: _____

Ending read: _____

HVLCS D Admin Personnel: _____

HVLCS D Field Personnel: _____

Consumption Fees collected by: _____

Permit revoked by: _____

RESOLUTION 2020-10
RESOLUTION OF THE BOARD OF DIRECTORS OF THE HIDDEN VALLEY LAKE
COMMUNITY SERVICES DISTRICT, COUNTY OF LAKE, STATE OF CALIFORNIA,
ADOPTING MOBILE AND STATIONARY METER USE FEES

WHEREAS, pursuant to Government Code section 66013, the Hidden Valley Lake Community Services District (the “District”) is authorized to impose fees for water connections, defined as the connection of a structure or project to a public water system.

WHEREAS, an analysis of the District’s water and sewer rates was prepared by NBS dated March 2015, entitled “Water and Sanitary Sewer Rate Study” (“Report”), a copy of which is on file in the Office of the District Secretary, and is hereby incorporated by reference; and

WHEREAS, on April 21, 2015, the District’s Board of Directors (the “Board”) approved and adopted the Report; and

WHEREAS, pursuant to Government Code 53755 and 53756, and Proposition 26, the Report establishes the cost of service providing water to the mobile or stationary meter as a fair and reasonable relationship to the payor’s burden on, or benefits received from, the District services, in the form of volumetric charge to this point of service, attached hereto as Exhibit “A”

WHEREAS, the District desires to implement water rates that will keep pace with the annual rate of inflation while reducing the administrative burden of annual modification; and

WHEREAS, pursuant to District Ordinance 57.1, the Board must establish and impose capacity fees, connection fees, and other miscellaneous fees and charges by resolution; and

WHEREAS, the California Environmental Quality Act (CEQA), Section 15273. Rates, Tolls, Fares, and Charges, states that CEQA does not apply to the establishment, modification, structuring, restructuring, or approval of rates, tolls, fares, or other charges by public agencies which the public agency finds are for the purpose of obtaining funds for capital projects, necessary to maintain service within existing service areas; meeting operating expenses; meeting financial reserve needs and requirements, and similar activities.

NOW, THEREFORE, BE IT RESOLVED:

1. The Board of Directors of the District finds and determines that the foregoing Recitals are true and correct, and hereby incorporates the Recitals herein.
2. The Mobile and Stationary Meter Use fees, as set forth in Exhibit “A”, attached hereto and incorporated herein, are hereby approved and adopted.
3. The revenue derived from the Mobile and Stationary Meter Use fees, as imposed and set forth in Exhibit "A" attached hereto, shall be used respectively for the exclusive purpose of providing facilities for water source, treatment and transmission of the Water System. Such revenues shall not be used to replace existing components of either the Water System except to the extent that such replacement provides additional capacity to the Water System. Said revenues shall be maintained in separate funds and are not to be considered as or commingled with any other funds of the utilities system.
4. The Mobile and Stationary Meter Use fees, as set forth in Exhibit "A", shall become effective immediately upon adoption of this Resolution.

5. If any section, subsection, clause, phrases, or portion of this Resolution is for any reason held to be invalid or unconstitutional by the decision of any court of competent jurisdiction, such decision shall not affect the validity of the remaining portions of this Resolution.
6. All other previously approved Mobile and Stationary Meter Use fees are rescinded upon adoption of this Resolution.

This Resolution shall be effective immediately upon adoption and shall remain in effect until such time as modified, repealed, or superseded by further resolution of the Board.

PASSED AND ADOPTED on _____, 2020 by the following vote:

AYES:

NOES:

ABSTAIN:

ABSENT:

Jim Lieberman,
President of the Board of Directors

ATTEST: _____
Penny Cuadras,
Secretary to the Board of Directors

EXHIBIT A

Application/Permit Processing	\$40
Volumetric Rate	\$6.70/HCF
Deposit (refundable upon permit return)	\$3200
Total initial costs:	\$3,240